

# PRODUCT CATALOGUE

2023  
24

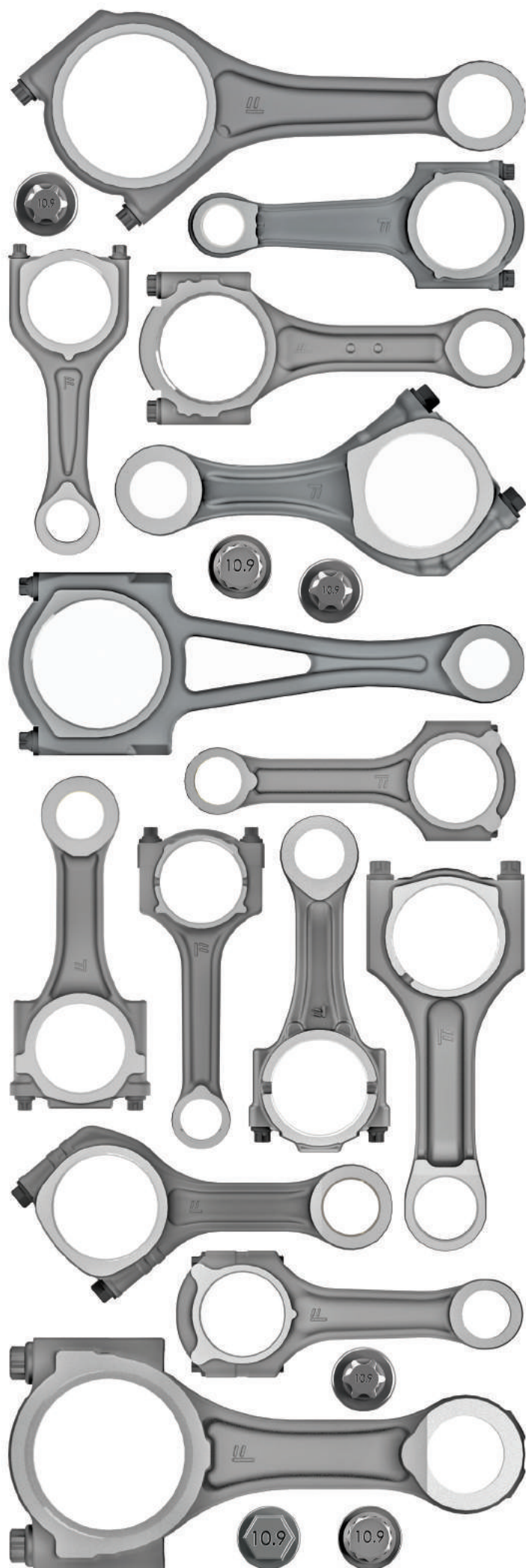

**BMYY**®  
CONNECTING  
ROD

**CONNECTING ROD & COMPONENTS**  
PLEUELSTANGE & KOMPONENTEN  
PISTON KOLU & EKİPMANLARI

**HELLO | HALLO | MERHABA****1971**

The foundations of our company were laid by Salih Öztaş with the opening of a 35m<sup>2</sup> motor rectification shop.

**1979**

We moved to an 300 m<sup>2</sup> area in Konya Karatay industrial site.

**1994**

With Crankshaft welding, we have started our complete crankshaft revision activities and we have incorporated Surface Roughness and Hardness Testing, Electromagnetic Crankshaft Inspection systems into our company.

**In this catalogue,**

In this catalogue we offer you the products of BMY which is the best aftermarket connecting rod manufacturer. Having proven itself in the international automotive spare parts market, especially in the production of connecting rods of light commercial and passenger vehicles, BMY is a supplier to the world's leading automotive companies. Quality products, reassuring sales and after-sales services, product variety, fast shipping, 100,000 km engine warranty are among the most important reasons for choosing BMY products. Today, as BMY, we are experiencing the happiness of this trust and preference. We continue to grow by sharing our happiness, trust and earnings with our suppliers, customers and employees. You can always contact BMY about our company and our products in this catalogue. We would like to express our deepest gratitude to you for your interest. Together to many great happiness and success ...

BMY Family

***In diesem Katalog,***

In diesem Katalog bieten wir Ihnen die Produkte von BMY an, dem besten Hersteller von Pleuelstangen für den Ersatzteilmarkt. BMY hat sich auf dem internationalen Markt für Kfz-Ersatzteile, insbesondere bei der Herstellung von Pleueln für leichte Nutz- und Personenkraftwagen, bewährt und ist Zulieferer der weltweit führenden Automobilunternehmen. Qualitätsprodukte, beruhigende Verkaufs- und Kundendienstleistungen, Produktvielfalt, schneller Versand und 100.000 km Motorgarantie sind die wichtigsten Gründe für die Wahl von BMY-Produkten.

## 1996

We started our wholesale spare parts sales activities.

## 2003

We moved to our new location of 2000m<sup>2</sup>

## 2008

We have obtained ISO 9001: 2008 Quality Certificate.

## 2009

We have started Connecting Rod Manufacturing

## 2016

We have expanded our factory site for flexible and efficient production. Molding operations started in own factory. We have founded Quality Control Laboratory.

## 2017

Hot forging operations started in-house.



## 2018

Updated ISO 9001: 2015 Quality Certificate. We have started to apply Product Liability Insurance for all products.

## 2019

In order to increase our production efficiency, to use our machine, human, time and raw material resources in the most effective way and to minimize human error, we have implemented ERP (Enterprise Resource Planning) software. We chose Canias ERP which is one of the best software in its field on a global scale.

## 2021

Double disc grinding and torquing units with automatic transducer were put into operation.

## 2022

We moved to our new factory for new products, fast shipping, higher volume production.

## 2023

We made a new forging investment in order to forge products for heavy vehicles, construction equipment, railways, agricultural group, energy sector.

Heute erleben wir als BMY das Glück dieses Vertrauens und dieser Präferenz. Wir wachsen weiter, indem wir unser Glück, Vertrauen und Ergebnis mit unseren Lieferanten, Kunden und Mitarbeitern teilen. Sie können BMY jederzeit über unser Unternehmen und unsere Produkte in diesem Katalog kontaktieren. Wir möchten Ihnen unseren tiefsten Dank für Ihr Interesse aussprechen. Zusammen zu vielen großen Glück und Erfolg ...

BMY Familie

### Bu Katalogda,

Size dünyanın en iyi aftermarket biyel kolu üreticisi olan BMY'nin ürünlerini sunmaktayız. Özellikle hafif ticari ve binek araçların biyel kolları üretiminde kendini uluslararası otomotiv yedek parça pazarında ispatlayan BMY, dünyanın önde gelen otomotiv firmalarına tedarikçilik yapmaktadır. Kaliteli ürünler, güven veren satış ve satış sonrası hizmetleri, ürün çeşitliliği, hızlı sevkiyatı, 100.000 km motor garantisi BMY ürünlerinin en önemli tercih sebeplerindedir. Bugün BMY olarak bu güvenin ve tercihlerin mutluluğunu yaşıyoruz. Mutluluğumuzu, güvenimizi ve kazancı tedarikçilerimizle, müşterilerimizle, çalışanlarımızla paylaşarak büyümeye devam ediyoruz. Bu katalogda bulunan ürünlerimiz ve firmamızla ilgili BMY ile her zaman iletişime geçebileceğinizi belirtmek isteriz. Göstermiş olduğunuz ilgiden dolayı en derin teşekkürlerimizi sunarız. Hep beraber nice büyük mutluluk ve başarılarla...

BMY Ailesi

**BMY<sup>®</sup> CONNECTING ROD**

**Kalite Politikamız**

Ahlak ve vicdan dışı değer çarpmadıkla, en iyi şekilde çalışarak, katma değerli ürünler üretmek.

Ne üretirizmiş bilkiçyle, gizli sevnek en iyi şekilde yapmak.

En iyi şekilde yapığımız işlerimize, müşterilerimize ve ürün kullanıcılarımıza mutlu etmek.

Mutlu müşterilerimizin sayısına her geçen gün artarak, sektörümüzde global bir marka haline getirmek.

Sevilen ve saygı duyulan global bir marka olarak, temsilatörlük mood çizmek.

**Our quality policy**

To produce value-added products by working in the best way within the framework of moral and conscientious values.

To do our job in the best way with the awareness of what we produce

To make our customers and product users happy with the works we do in the best way.

To become a global brand in the sector by increasing the number of our happy customers day by day.

To be a role model to societies as a loved and respected global brand.

**BMY<sup>®</sup> CONNECTING ROD**

**Taahhütümüzdür**

BMY yönetimi Gerekli tesislerinde, eşitlikli beşeri ve fiziki unsurları sağlama ve güvence altına almıştır.

Personelini karp adı çizmek ve ayarını yapmaktır. Kılışıklemek, etiklik kökünü, öl, din ve dinaiyet ayarını yapmaktır.

Düğünce ve fikir özünlemeden saygı duyarak ve bunu garanti altına almaktır.

Katılımı, kapsayıcı, paydaşını, barışçıl özü, fevri eğitilmiş sağlamaktır.

İş sağlığı ve güvenliği kurallarına riayet edenlik, hususiyetle uyulması ve katılıp çizmek.

**Our Commitment**

BMY management has ensured that the following humane and physical elements are provided in the production facilities:

To be fair to their staff and not to discriminate. Not to polarize, not to discriminate based on ethnicity, language, religion and gender.

To respect and guarantee freedom of thought and opinion.

To be participatory, inclusive, sharing, peaceful and provide equal opportunity.

To be a practitioner and follower of occupational health and safety rules.

**BMY<sup>®</sup> CONNECTING ROD**

Müşterilerimiz için değer yaratmak, beklentilerine kalite ve sekinlik karşılık vermek için önceliktir. Ürünlerimizle sahip çizmek ve satış sonrasında da müşterilerimizin yanlarında çizmek görevimizdir. Ürün ve hizmetimizin kalitesi ekibimizin kalitesiyle bağlar. En iyi personeli ve yetiştirilmiş insan gücünü istihdam etmek, insanımızın yeteneklerinden ve yaratıcılığında en üst düzeyde fayda sağlanarak, verimlilikleri artarak, gelişmelerine imkan tanıyarak ve dayanımlarını özdeği bir çalgısına ortam yaratmak, şirketimizin kuyuları boyu devamlağın sağlanarak için stratejimizdir. Teberleğinle ve müşterilerimize, tüm insanı ve ticari ilişkilerinde adli, iyi riayet ve anlayışla davranarak, yazara ve ahlak kurallarına uyarak vazeçilmez ilkimizdir.

Our first priority is to create value for our customers and to respond to their expectations with quality and stability. It is our duty to stick by our products and to be with our customers after sales. The quality of our product and business starts with the quality of our team. In order to ensure the continuity of our company for generations, our strategy is to employ the best personnel and trained manpower, to benefit from the talents and creativity of our people at the highest level, to increase their productivity, to enable them to develop and to create a working environment with stability. It is our indispensable principle to behave fairly, in good faith and understanding in all our human affairs and commercial relations with our suppliers and customers, and to comply with the laws and ethical rules.

VİZYONUMUZ

MİSYONUMUZ

İLKELERİMİZ

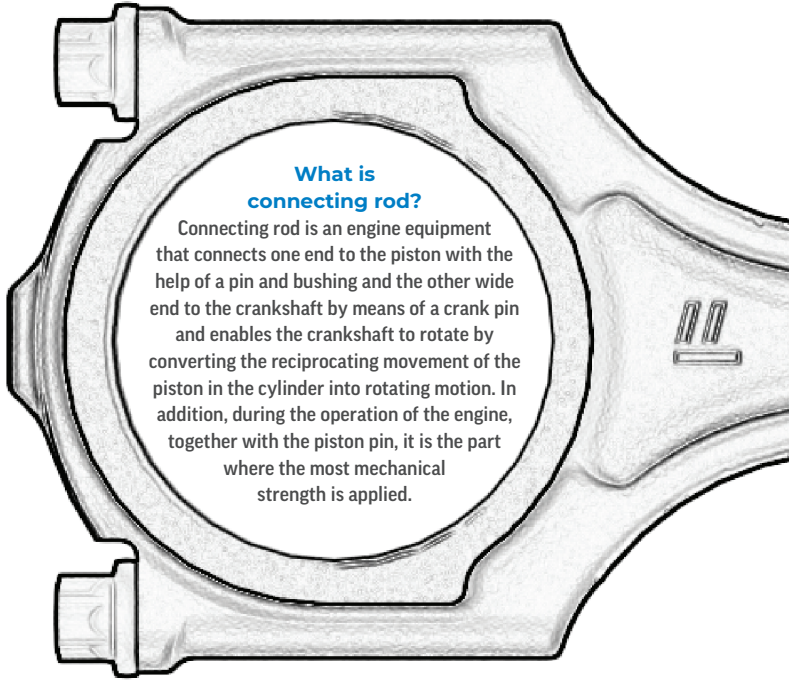

### What is connecting rod?

Connecting rod is an engine equipment that connects one end to the piston with the help of a pin and bushing and the other wide end to the crankshaft by means of a crank pin and enables the crankshaft to rotate by converting the reciprocating movement of the piston in the cylinder into rotating motion. In addition, during the operation of the engine, together with the piston pin, it is the part where the most mechanical strength is applied.

### Was ist Pleuelstange?

Die Pleuelstange ist eine Motorausüstung, die ein Ende mit Hilfe eines Stifts und einer Buchse mit dem Kolben und das andere breite Ende mit Hilfe eines Kurbelzapfens mit der Kurbelwelle verbindet und es der Kurbelwelle ermöglicht, sich zu drehen, indem die Hin- und Herbewegung des Kolbens umgewandelt wird der Zylinder in Drehbewegung. Darüber hinaus ist es während des Betriebs des Motors zusammen mit dem Kolbenbolzen der Teil, an dem die meiste mechanische Festigkeit angewendet wird.

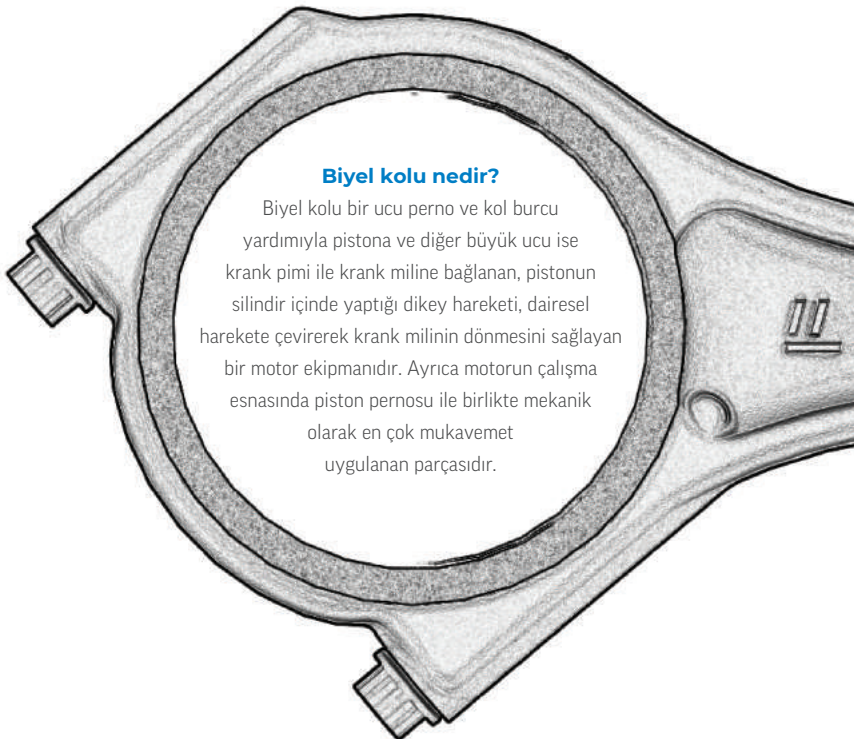

### Biyel kolu nedir?

Biyel kolu bir ucu perno ve kol burcu yardımıyla pistonu ve diğer büyük ucu ise krank pimi ile krank miline bağlanan, pistonun silindir içinde yaptığı dikey hareketi, dairesel harekete çevirerek krank milinin dönmesini sağlayan bir motor ekipmanıdır. Ayrıca motorun çalışma esnasında piston pernosu ile birlikte mekanik olarak en çok mukavemet uygulanan parçasıdır.

### Did you know ?

Connecting rod is firstly used by scientist Ismail Al-Jazari in Cizre which is in the southeast of Turkey, in 1198 in order to pump water.

The connecting rod, which has been developed over time, has been used in steam locomotives and mill machines, and today it continues to exist in gasoline, diesel, hybrid and hydrogen engines.

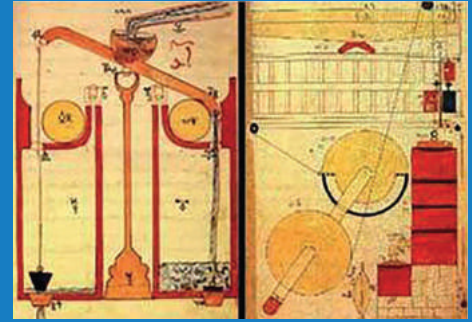

### Wussten Sie schon ?

Die Pleuelstange wird erstmals 1198 vom Wissenschaftler Ismail Al-Jazari in Cizre im Südosten der Türkei verwendet, um Wasser zu pumpen. Die im Laufe der Zeit entwickelte Pleuelstange wurde in Dampflokomotiven und Mühlenmaschinen eingesetzt und ist bis heute in Benzin-, Diesel-, Hybrid- und Wasserstoffmotoren vorhanden.

### Biliyor muydunuz ?

Biyel kolu ilk olarak 1198 yılında Türkiye'nin güney doğusunda bulunan Cizre'de, bilim adamı Ismail El-Cezeri tarafından su pompalamak amacıyla kullanılmıştır. Zamanla geliştirilerek buharlı lokomotiflerde, değirmen makinalarında kullanıldıktan sonra günümüzde, benzinli, dizel, hybrid ve hidrojenli motorlarda varlığını sürdürmektedir.



BMV products are manufactured with hot forging method.

BMV-Produkte werden im Heischmiedeverfahren hergestellt.

BMV rnleri sıcak dvme yntemiyle retilmektedir.



BMV uses rolled-locked type leadfree bushings which are made of steel outside and bronze inside. The high quality of the bushes prevents them from rotating in their bearings.

BMV verwendet bleifrei gewalzte Buchsen, die auen aus Stahl und innen aus Bronze bestehen. Die hohe Qualitt der Buchsen verhindert, dass sie sich in ihren Lagern drehen.

BMV, Dıı elik, ii sarı kurunsuz malzemedan kıvrıma ve kilitli tip olarak retilen kol burlarını kullanmaktadır. Yksek kaliteli kol burlarıyla, kol burcunun, yuvasında dnmesi engelenmi olur.



The cold forged bolts are of 10.9 and 12.9 quality.

Die kaltgeschmiedeten Schrauben haben eine Qualitt von 10,9 und 12,9.

Souk dvme yntemiyle retilen cıvatalar 10.9 ve 12.9 kalitesindedir.

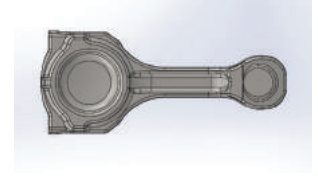

The weight is adjusted while still in the moulding phase with the CAD program, and the tolerances are kept inside minimum values range.

Das Gewicht wird noch in der Formphase mit dem CAD-Programm eingestellt und die Toleranzen werden innerhalb des Mindestwertbereichs gehalten.

Aırlık henz CAD programı ile kalıplama aamasındayken ayarlanıp, toleransları minimum seviyede tutulmaktadır.

**BMV has been producing with the know-how in engine technologies, which comes from experience of engine rebuilding since 1971. Today, it continues to produce with the steel forging method with brand new and state-of-the-art production lines.**

BMV produziert seit 1971 mit dem Know-how in Motorentechnologien, basierend auf Erfahrungen mit Motorreparaturen. Heute produziert BMV weiterhin im Stahlschmiedeverfahren mit brandneuen und hochmodernen Produktionslinien.

BMV Motor rektifiyecilikten gelen 1971 yılından beri motor teknolojilerinde sahip olduu know-how ile retimlerini gerekletirmektedir. Bugn yepyeni ve son teknoloji retim hatlarıyla, elik dvme yntemiyle retmeye devam ediyor.

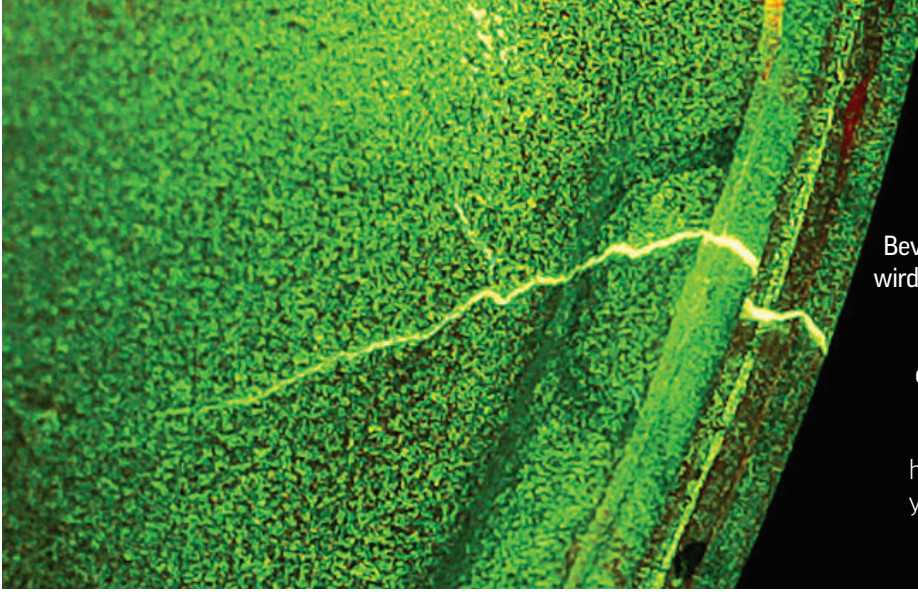

Before our connecting rods are forged, micro fracture control is performed while they are in raw material state. After forging, it is subjected to a fracture test again.

Bevor unsere Pleuel geschmiedet werden, wird die Mikrobruchkontrolle durchgeführt, während sie sich im Rohstoffzustand befinden. Nach dem Schmieden wird es erneut einem Bruchtest unterzogen.

Biyel kollarımız henüz dövülmeden hammadde halindeyken çatlak kontrolü yapılır. Dövüldükten sonra tekrar çatlak testine tabi tutulur.



Connecting rods are individually controlled for size, hardness and surface roughness. Each connecting rod produced is given an identity number and in case of any malfunction, its feedback can be obtained easily.

Pleuelstangen werden individuell für die Größe, die Härte und Oberflächenrauigkeit gesteuert. Jede produzierte Pleuelstange erhält eine Identifikationsnummer und im Falle einer Fehlfunktion kann ihre Rückmeldung leicht eingeholt werden.

Biyel kolları tek tek ölçü, sertlik ve yüzey pürüzlülük kontrolü yapılmaktadır. Üretilen her biyel kolu kimliklendirilerek herhangi bir aksaklıkta geri dönüşümü kolayca yapılabilir.

Cracked-type connecting rods are produced to prevent wear of connecting rod-cap connection surfaces, especially in high-torque vehicles, and to be long-lasting.

Connection points between rod and cap have hundreds of surfaces. Thus, the cap and rod surfaces deteriorate less and the engine life is prolonged. As a matter of fact, the cap mouths, which were designed as flat in the past, were later produced with milling.

Finally, cracked type connecting rods have been the choice of all engine manufacturers and designers.

Gebrochene Pleuel werden hergestellt, um den Verschleiß der Pleuelkappen-Verbindungsflächen, insbesondere bei Fahrzeugen mit hohem Drehmoment, zu verhindern und um eine lange Lebensdauer zu gewährleisten.

Verbindungspunkte zwischen Stange und Kappe haben Hunderte von Oberflächen. Dadurch verschlechtern sich die Oberflächen der Kappe und der Stange weniger und die Lebensdauer des Motors wird verlängert. Tatsächlich wurden die Kappenmündungen, die in der Vergangenheit als flach ausgelegt waren, später durch Fräsen hergestellt.

Schließlich waren gerissene Pleuel die Wahl aller Motorenhersteller und -konstrukteure.

Kırma tip biyel kolları, özellikle yüksek torklu araçlarda biyel-kep bağlantı yüzeylerinin aşınmaması ve uzun ömürlü olması için üretilmektedir.

Kol ve kep arasındaki bağlantı noktaları, yüzlerce yüzeye sahiptir. Böylelikle, kep ve kol yüzeyleri daha az bozulmakta, motor ömürleri uzamaktadır. Nitekim önceleri düz olarak tasarlanan kep ağızları, sonradan frezeli olarak üretilmiştir.

En nihayetinde kırma tip biyel kolları bütün motor üretici ve tasarımcısı firmaların tercihi olmuştur.

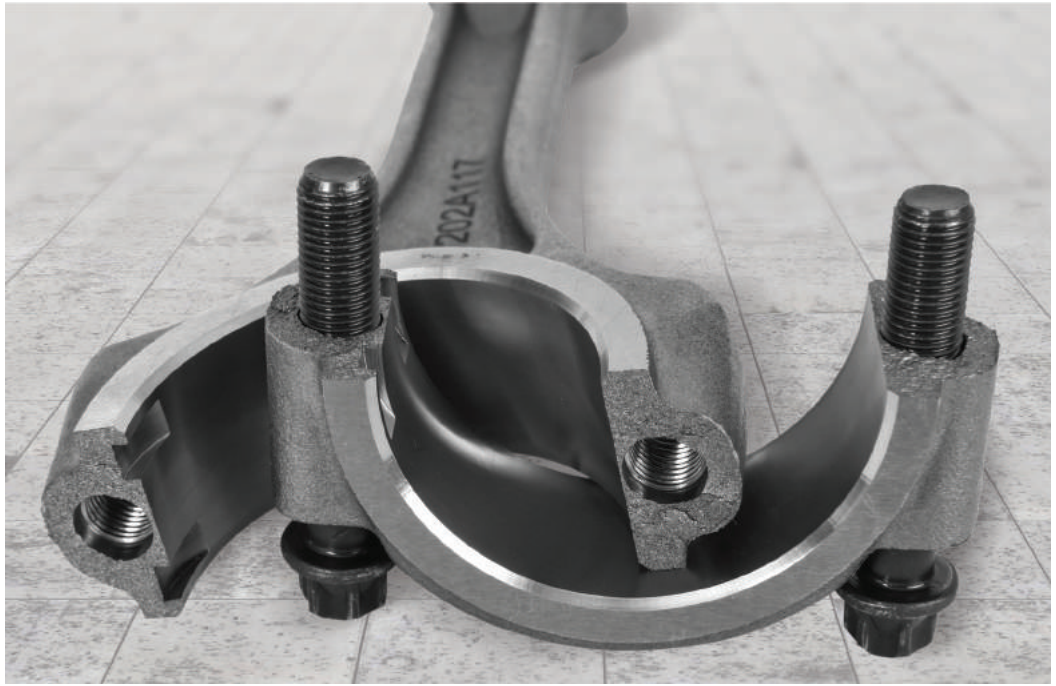
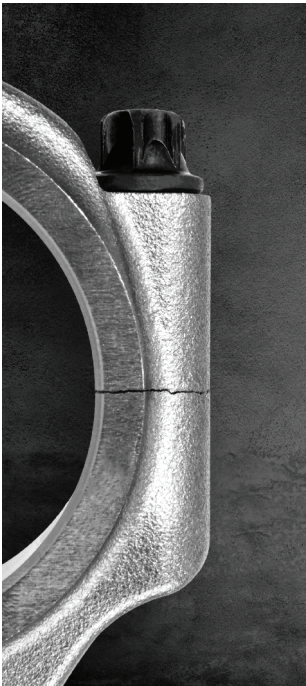



Garanti Bilgilendirme Formu

**Garanti Bilgilendirme Formu** **BMY** CONNECTING  
ROD

BMY Referans Numarası: BMY-\_\_\_\_\_  
 Ürün Kodu: BMY-\_\_\_\_\_  
 BMY Ürün Modeli (eğer varsa): BMY-\_\_\_\_\_  
 Model Adı: \_\_\_\_\_  
 Genel Kapsamda  Özel Kapsamda  
 Müşteri Adı: \_\_\_\_\_  
 Adres: \_\_\_\_\_  
 Telefon Numarası: \_\_\_\_\_  
 E-posta Adresi: \_\_\_\_\_  
 Aracın Türü:  Binek Arac  Traktör  Araçsız  Başka Arac  Diğer \_\_\_\_\_  
 Müşteri İmzası: \_\_\_\_\_  
 Tarih: \_\_\_\_\_

Bu form ve diğer belgeler diğer tarafta belirtilen süre ve koşullarda geçerlidir.



Warranty Notice Form

**Warranty Notice Form** **BMY** CONNECTING  
ROD

BMY Referans Numarası: BMY-\_\_\_\_\_  
 Ürün Kodu: BMY-\_\_\_\_\_  
 BMY Ürün Modeli (eğer varsa): BMY-\_\_\_\_\_  
 Model Adı: \_\_\_\_\_  
 Genel Kapsamda  Özel Kapsamda  
 Müşteri Adı: \_\_\_\_\_  
 Adres: \_\_\_\_\_  
 Telefon Numarası: \_\_\_\_\_  
 E-posta Adresi: \_\_\_\_\_  
 Aracın Türü:  Binek Arac  Traktör  Araçsız  Başka Arac  Diğer \_\_\_\_\_  
 Müşteri İmzası: \_\_\_\_\_  
 Tarih: \_\_\_\_\_

Bu form ve diğer belgeler diğer tarafta belirtilen süre ve koşullarda geçerlidir.

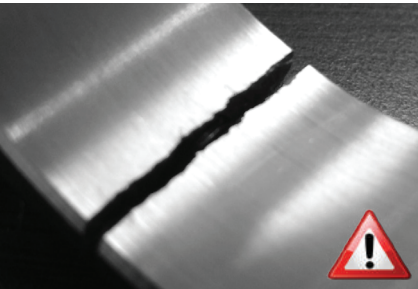
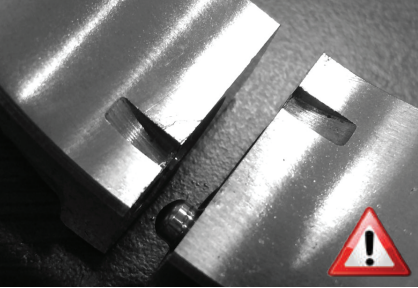
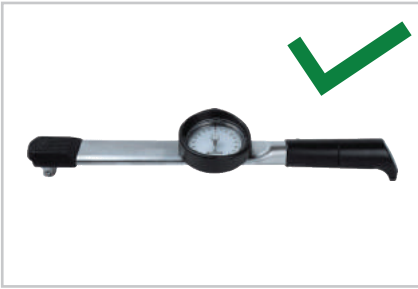
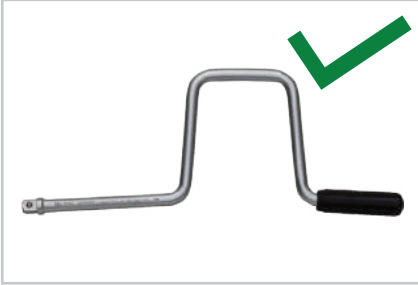

## Montage Instructions

Please check the product you ordered by comparing informational labels on the box.

Although normally there is no problem with their weights, it is recommended to check their weights before assembly. For the products out of weight tolerance range, please contact BMY.

Connecting rod bolts should be torqued according to the values determined by Engine Manufacturer Company. It is recommended to oil connecting rod bolts during montage and high-pressure screwing tools must not be used.

While assembling rod bearings, attention should be paid to the lug location directions and identical numbers on the rod parts. The cracked-type rods without lug should be assembled by carefully fitting each other and by paying attention to the production numbers on each sides.

## Montageanleitung

Bitte überprüfen Sie das von Ihnen bestellte Produkt, indem Sie die Informationsetiketten auf der Verpackung vergleichen. Obwohl normalerweise kein Problem mit den Gewichten besteht, wird empfohlen, die Gewichte vor dem Zusammenbau zu überprüfen.

Für Produkte außerhalb des Gewichtstoleranzbereichs wenden Sie sich bitte an BMY. Die Pleuelschrauben sollten ein Drehmoment gemäß den von der Engine Manufacturer Company festgelegten Werten aufweisen. Es wird empfohlen, die Pleuelschrauben während der Montage zu ölen, und es dürfen keine Hochdruck-Schraubwerkzeuge verwendet werden.

Bei der Montage der Pleuel-Stangenlager sollten die Richtungen der Lugposition und die identischen Nummern auf den Pleuel-Stangenteilen beachtet werden. Die gerissenen Pleuel-Stangen ohne Ansatz sollten zusammengebaut werden, indem sie sorgfältig zusammengefügt werden und die Produktionsnummern auf jeder Seite beachtet werden.

## Montaj Kılavuzu

Kutu üzerindeki bilgilendirici etiketle istediğiniz ürünü karşılaştırarak kontrol ediniz.

Ürünlerde ağırlık problemi olmamasına rağmen montajdan önce ağırlık kontrolünün yapılması tavsiye edilir. Ağırlıkları toleransların dışında olan ürünler için BMY ile iletişime geçiniz.

Bağlantı saplamaları motor üretici firmanın belirlediği veya BMY Katalogundaki değerlere göre torklanmalıdır. Bağlantı saplamaları montajlanırken yağlanması tavsiye edilir ve kesinlikle yüksek hava basınçlı sıkma aletleri kullanılmamalıdır.

Kol yataklarının montajında tırnak yeri yönlerine ve kol üzerinde ki eş imalat numaralarına dikkat edilmelidir. Tırnak yeri olmayan kırma tip piston kollarında üretim numarasına dikkat edilerek, kırık yüzeyler birbirine dikkatlice geçirilerek montajlanmalıdır.

Perno ölçülerine ve temizliğine montajdan önce dikkat edilmelidir.

Engine Type	Models	Picture	Sizes (mm)	Products	BMY Reference
<b>1</b>					
<b>A</b> Iveco - Fiat F1AE	Iveco Daily Fiat Ducato UAZ Patriot			<b>J</b> Connecting Rod STD - Tapered	<b>BMY1405</b> 1 pc.30x12x6cm <b>P</b>
<b>B</b> 2.3 cc	Karsan Jest/J10			<b>K</b> Connecting Rod SEMI - Tapered	<b>BMY1405SEMI</b> 1 pc.30x12x6cm <b>Q</b>
<b>C</b> R4	<b>E</b>	<b>F</b>		<b>L</b> Bushing Bimetal Locked-Straight	<b>BMY1405B</b> 4 pcs. 10x6x4cm <b>R</b>
				<b>M</b> Bolt - 10.9 M10x1,25 L: 49	<b>BMY1405CB</b> 8 pcs. 10x6x4cm <b>S</b>
				<b>N</b> Con. Rod OEM :504 341 501 504 057 276	
	<b>D</b>				
					<b>T</b>

<b>A</b> Engine Type Motortyp Motor Tipi	<b>K</b> Connecting Rod SEMI - Un-bored Con. Rod Bushing Connecting Rod SEMI - Un-bohren Bushing SEMI - Kol Burcunun içi işlenmemiş
<b>B</b> Engine Capacity Hubraum Motor Hacmi	<b>L</b> Type of Bushing Art der Buchse Kol Burcunun Tipi
<b>C</b> Number of Cylinders - Array Anzahl der Zylinder - Array Silindir Sayısı - Dizilimi	<b>M</b> Sizes and Specification of Bolt Größen und Spezifikation der Schraube Cıvatanın ölçüleri - kalitesi
<b>D</b> Fuel Type / Vehicle Types Kraftstoff / Fahrzeugtypen Yakıt Türü / Araç Tipleri	<b>N</b> Cross Numbers of Products Kreuz Anzahl der Produkte Ürünlerin Eşdeğer Numuneleri
<b>E</b> Using Manufacture Models Fahrzeugmodelle Kullanan Araç Modelleri	<b>O</b> Name of Engine Manufacturer Name des Motorenherstellers Motor Üreticisi
<b>F</b> Picture of Con. Rod and Bolt Bild von Pleuel und Bolzen Piston Kolu ve Cıvata Resmi	<b>P</b> Reference of Connecting Rod In-box quantity - Box Sizes Referenz der Pleuelstange In-Box Menge - Box Größen Piston kolu Referansı Kutu içi miktarı - Kutu Ebatları
<b>G</b> Weight of Connecting Rod Gewicht der Pleuelstange Piston Kolu Ağırlığı	<b>Q</b> Reference of SEMI Connecting Rod In-box quantity - Box Sizes Referenz der SEMI Pleuelstange In-Box Menge - Box Größen SEMI Piston kolu Referansı Kutu içi miktarı - Kutu Ebatları
<b>H</b> Bolt Torque Bolzen-Drehmoment Cıvata Torku	<b>R</b> Reference of Bushing - In-box quantity - Box Sizes Referenz der Buchse - In-Box-Menge - Box Größen Kol Burcu Referansı - Kutu içi miktarı - Kutu Ebatları
<b>I</b> Basic Product Dimensions Produktabmessungen Ürün Ölçüleri	<b>S</b> Reference of Bolt - In-box quantity - Box Sizes Referenz der Schrauber - In-Box-Menge - Box Größen Cıvata Referansı - Kutu içi miktarı - Kutu Ebatları
<b>J</b> Connecting Rod STD - Milled Con. Rod Bushing Connecting Rod STD - Geprägte Con. Rod Bushing Connecting Rod STD - Kol Burcunun içi işlenmiş	<b>T</b> Structure of Connecting Rod Type of Connecting Rod Shape of Small End Struktur der Pleuelstange Art der Pleuelstange Form des kleinen Endes Piston Kolu Yapısı Piston Kolu Türü Perno Yeri Kesiti



## INHALTSVERZEICHNIS























### ÜRETİCİ LİSTESİ











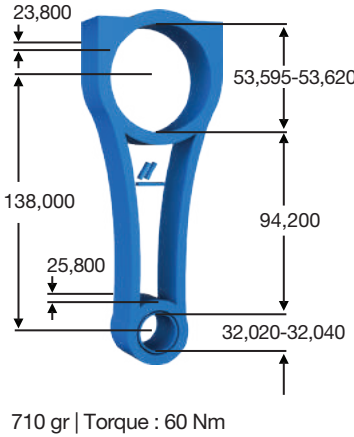







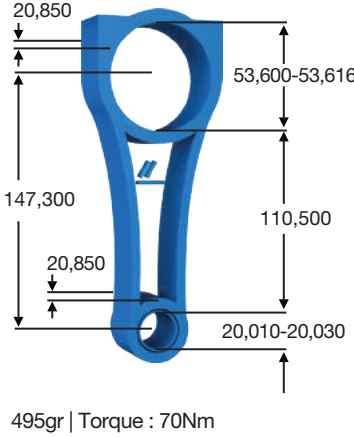

<b>A</b>	ALFA ROMEO	15
	AUDI	61
<b>B</b>	BMW	12
	BUICK	46
<b>C</b>	CHEVROLET	46
	CHRYSLER	46
	CITROEN	51
<b>D</b>	DETROIT DIESEL	Mercedes-Benz 38
	DEUTZ	67
	DS	51
<b>F</b>	FIAT	15
	FORD	19
<b>G</b>	GM	46
<b>H</b>	HYUNDAI	24
<b>I</b>	ISUZU	26
	IVECO	29
<b>J</b>	JAGUAR	32
	JEEP	15
	JENBACHER	31
<b>K</b>	KARSAN	Isuzu 27   Iveco 29
	KIA	24
<b>L</b>	LANCIA	15
	LAND ROVER	32
	LOTUS	GM   Opel 46
<b>M</b>	MAZDA	FORD 21   PSA 52
	MASERATI	FCA 17
	MERCEDES-BENZ	34
<b>N</b>	MINI	12
	MITSUBISHI	49
	MTU	Mercedes-Benz 38
<b>O</b>	NISSAN-INFINITI	42
<b>O</b>	OPEL	46
<b>P</b>	PERKINS-MASSEY FERGUSON	49
	PEUGEOT	51
	PORSCHE	50
<b>R</b>	RENAULT	55
	RAM	FCA 17
<b>S</b>	SAAB	GM   Opel 46
	SEAT	61
	SKODA	61
<b>T</b>	TATA	Fiat 15
	TOYOTA - LEXUS	60
<b>V</b>	VAUXHALL	46
	VOLVO	PSA 53   Renault 56
	VOLKSWAGEN	61
	VM	FCA 17

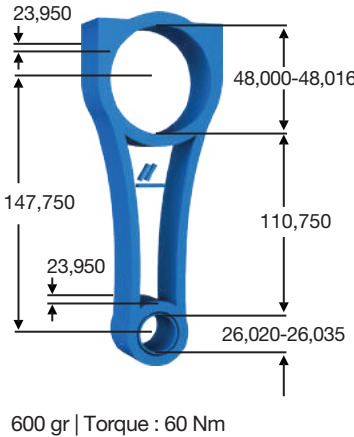

All manufactures names, numbers and descriptions only are shown for reference. It doesn't mean that these products are original. The products that indicated in the catalog are aftermarket spare parts and made in Turkey.

Alle Herstelleramen, -nummern und -beschreibungen werden nur als Referenz angezeigt. Das bedeutet nicht, dass diese Produkte original sind. Bei den im Katalog angegebenen Produkten handelt es sich um Ersatzteile für den Aftermarket, die in der Türkei hergestellt werden.

Katalogda belirtilen tüm üretici isimleri, numaraları ve açıklamaları sadece referans olarak gösterilmiştir. Bu bilgiler ürünlerin orijinal olduğu anlamına gelmez. Katalogda belirtilen ürünler satış sonrası yedek parçalarıdır ve Türkiye'de üretilmektedir.

Engine Type	Models	Picture	Sizes (mm)	Products	BMY Reference
<b>1</b>					
<p>BMW N47 D20A/B N47S</p> <p>N57 D30 A/B/D OL/TOP</p> <p>N57 306 D2/D3 N57N 306 D2/ D3/D5</p> <p>B47 D20 A/B B57 D30 A/B/C</p>	<p>BMW 320d, 325d, 330d, 430d, 520d, 525d, 530d, 550d, 640d, 730d, X3, X4, X5, X6</p> <p>E81, E82, E83, E87, E88, E90, E91, E92, E60, E61, F10, F30, F01, F02, F03, F31, F32, F33, F36, F11, F45, F20, F22, F26, F40, F56, G01, G02, G11, G15, G20, G30, G31, G32</p>		<p>23,800</p> <p>53,595-53,620</p> <p>138,000</p> <p>25,800</p> <p>95,200</p> <p>32,020-32,040</p> <p>720 gr   Torque : 70 Nm</p>	<p>Connecting Rod STD</p> <p>Connecting Rod SEMI</p> <p>Bushing Bimetal Locked-Straight</p> <p>Bolt - 10.9 M9x1 L: 46 mm</p> <p>Con. Rod OEM : 11247807345, 11248508023</p>	<p><b>BMY1701</b> 1 pc.24x10x4cm</p> <p><b>BMY1701SEMI</b> 1 pc.24x10x4cm</p> <p><b>BMY1701B</b> 4 pcs.10x6x4cm</p>
  		  			
<b>2</b>					
<p>BMW N20, B20, A/B/C/D N26/ B20 A</p> <p>R4</p> <p>BMW N52/N B30 A/AE/B/BE/BF N53 B30 /A N55 B30 A</p> <p>R6</p>	<p>BMW 120i, 125i, 130i, 135i, 220i, 228i, 320i, 328i, 330i, 335i, 420i, 428i, 430i, 435i, 520i, 530i, 535i, 640i, 740i, X1, X3, X4, X5, X6, Z4, xDrive, sDrive, ActiveHybrid</p> <p>F10, F11, F15, F20, F21, F22, F23, F25, F30, F31, F34, F36, F80, E84, F87</p>		<p>20,850</p> <p>53,600-53,616</p> <p>144,350</p> <p>20,850</p> <p>106,550</p> <p>22,004-22,013</p> <p>575 gr   Torque : 60 Nm</p>	<p>Connecting Rod STD</p> <p>Connecting Rod SEMI</p> <p>Bushing Bimetal Locked-Straight</p> <p>Bolt - 10.9 M9x1 L: 46 mm</p> <p>Con. Rod OEM : 11247624616, 11247624615, 11247589540</p>	<p><b>BMY1702</b> 1 pc.24x10x4cm</p> <p><b>BMY1702SEMI</b> 1 pc.24x10x4cm</p> <p><b>BMY1702B</b> 4 pcs. 10x6x4cm</p>
   		  			
<b>3</b>					
<p>BMW/MINI/Alpina N47 C20 A N47 D20 C</p> <p>B47 C20 U0</p> <p>Forging No: 543</p> <p>2.0 cc</p> <p>R4</p>	<p>F45, F48, F54, F30, G20</p> <p>X1, 218d, 120d, 320d</p> <p>MINI Clubman, Countryman, Clubvan, Coupe, Cooper</p>		<p>23,850</p> <p>53,600-53,616</p> <p>143,000</p> <p>25,850</p> <p>102,550</p> <p>28,020-28,035</p> <p>684 gr   Torque : 60 Nm</p>	<p>Connecting Rod STD</p> <p>Connecting Rod SEMI</p> <p>Bushing Bimetal Locked-Straight</p> <p>Bolt - 10.9 M9x1 L: 46 mm</p> <p>Con. Rod OEM : 11247812640</p>	<p><b>BMY1703</b> 1 pc.24x10x4cm</p> <p><b>BMY1703SEMI</b> 1 pc.24x10x4cm</p> <p><b>BMY1703B</b> 4 pcs.10x6x4cm</p>
  		  			

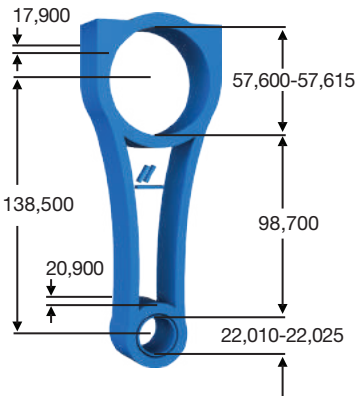









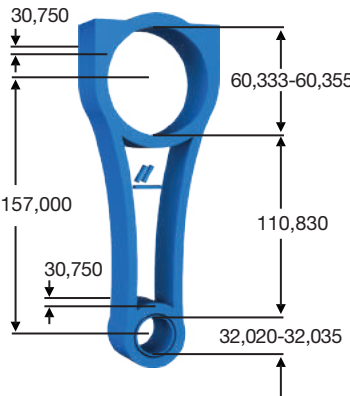



Engine Type	Models	Picture	Sizes (mm)	Products	BMY Reference
<p><b>4</b></p> <p>BMW N57 D30 S1 N57S N57 D30 C Tri-Turbo</p> <p>3.0 cc</p>	<p>F01, F02, F10, F11, F15, F16 E70, E71</p> <p>750dX, 750LdX, X5 M50dX, X6 M50dX, M550dX</p>		 <p>710 gr   Torque : 60 Nm</p>	<p>Connecting Rod STD</p> <p>Bushing Bimetal Locked-Straight</p> <p>Bolt - 10.9 M9x1 L: 46 mm</p> <p>Con. Rod OEM: 11248506122</p>	<p><b>BMY1704</b> 1 pc.24x10x4cm</p> <p><b>BMY1701B</b> 4 pcs.</p>
  				  	
<p><b>5</b></p> <p>BMW N43B20</p> <p>Forging Number: 543</p> <p>2.0cc</p> <p>R4</p>	<p>E81, E82, E87 E88, E90, E91 E93, E60, E61</p> <p>116i, 118i, 120i 318i, 320i 520i</p>		 <p>495gr   Torque : 70Nm</p>	<p>Connecting Rod STD</p> <p>Connecting Rod SEMI</p> <p>Bushing Bimetal Locked-Straight</p> <p>Bolt - 10.9 M9x1 L: 46 mm</p> <p>Con. Rod OEM: 11247589533</p>	<p><b>BMY1705</b> 1 pc.24x10x4cm</p> <p><b>BMY1705SEMI</b> 1 pc.24x10x4cm</p> <p><b>BMY0808B</b> 4 pcs. 10x6x4cm</p>
 				  	
<p><b>6</b></p> <p>BMW/MINI N47 C16 N47 D16</p> <p>Toyota 1WW</p> <p>Forging Number: 546</p> <p>1,6 cc</p> <p>R4</p>	<p>F20 114d, 116d</p> <p>Cooper D</p> <p>Toyota Auris, Avensis, Verso</p>		 <p>600 gr   Torque : 60 Nm</p>	<p>Connecting Rod STD</p> <p>Connecting Rod SEMI</p> <p>Bushing Bimetal Locked-Straight</p> <p>Bolt - 10.9 M9x1 L: 46 mm</p> <p>Con. Rod OEM: 11247812641</p>	<p><b>BMY1706</b> 1 pc.24x10x4cm</p> <p><b>BMY1706SEMI</b> 1 pc.24x10x4cm</p> <p><b>BMY1706B</b> 4 pcs. 10x6x4cm</p>
 				  	

Engine Type	Models	Picture	Sizes (mm)	Products	BMY Reference
<b>7</b> BMW / Alpina N63 N N63 B44 S63 B44  Forging Number: 22  Land Rover P530  4.4 cc  V8  Range Rover/ Sport L460 /L461	X5, X6, 750i, 750Li, 550i, M550i, 650i /xDrive /M E70, E71, F01, F02, F06, F07, F10, F11, F12, F13, F15, F16, F85, F86, F90, F91, F95, F96, G05, G06, G07, G11, G12, G14, G15, G16, G30, G31		17,900 57,600-57,615 138,500 20,900 98,700 22,010-22,025  580 gr   Torque : 70 Nm	Connecting Rod STD  Connecting Rod SEMI  Bushing Bimetal Locked-Straight  Bolt - 10.9 M9x1 L: 46 mm  Con. Rod OEM: 11247646892	<b>BMY1707</b> 1 pc.24x10x4cm  <b>BMY1707SEMI</b> 1 pc.24x10x4cm  <b>BMY1707B</b> 4 pcs. 10x6x4cm  <b>BMY1707CB</b> 8 pcs.10x6x4cm
<b>8</b> BMW N20B16  Forging Number: 13  1.6cc  R4	F10 Facelift G30, G20 E84 F23  520i 320i  X1 16i X3 18i		20,850 53,600-53,616 153,300 20,850 115,500 22,004-22,013  595 gr   Torque : 60 Nm	Connecting Rod STD  Connecting Rod SEMI  Bushing Bimetal Locked-Straight  Bolt - 10.9 M9x1 L: 46 mm  Con. Rod OEM: 11 24 8 610 991	<b>BMY1708</b> 1 pc.24x10x4cm  <b>BMY1708SEMI</b> 1 pc.24x10x4cm  <b>BMY1708B</b> 4 pcs. 10x6x4cm  <b>BMY1708CB</b> 8 pcs.10x6x4cm
<b>9</b> BMW - MINI N13 B16 N14 B16 N18 B16 PSA EP6, EP6DT, EP8CDTX  1.6 cc  R4	BMW 114i, 116i, 118, 316i, 320i Efficient Dynamics Edition  F20, F30  MINI Cooper  Peugeot 207, 208, 2008, 308, 3008, 508 Citroën C4, DS3, DS4, C3		20,850 47,995-48,020 138,550 20,850 104,530 20,020-20,040  465 gr   Torque : 45 Nm 2nd Torque Option : 5 Nm + 15 Nm + 130 °	Connecting Rod STD  Connecting Rod SEMI  Bushing Bimetal Locked-Straight  Bolt - 10.9 M7x1 L: 38 mm  Con. Rod OEM 11247621253 BMW 0603 96, 161 366 51 80 PSA	<b>BMY0808</b> 1 pc.24x10x4cm  <b>BMY0808SEMI</b> 1 pc.24x10x4cm  <b>BMY0808B</b> 4 pcs.10x6x4cm  <b>BMY0806CB</b> 8 pcs.10x6x4cm

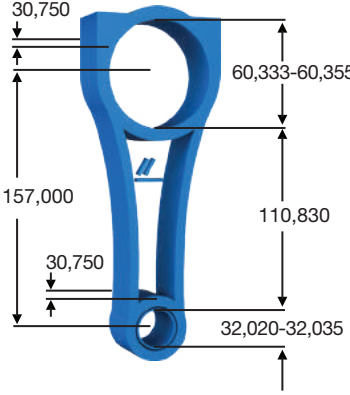









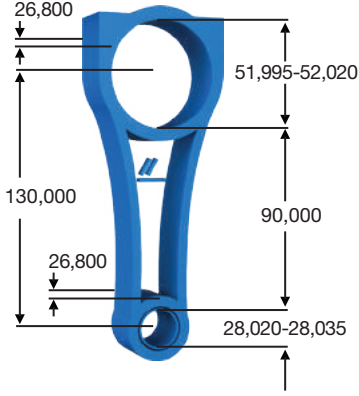







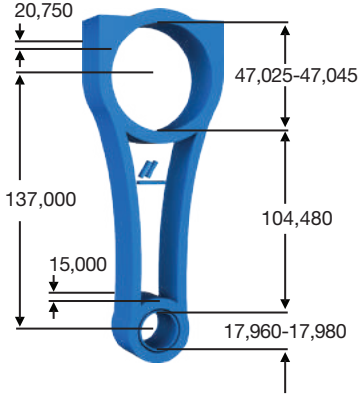

Engine Type	Models	Picture	Sizes (mm)	Products	BMY Reference	
<b>1</b>						
Fiat 1.3 JTD 169 A1, 169 A5, 188 A8, 188 A9. 199 A1, 199 A2, 199 A3, 199 A9, 199 B1 Euro 5, 199 B2 Euro 5, 199 B4, 223 A9, 225 A2, 263 A2 Euro 5, 263 A6 312 A8.000 Euro 6, 312 B1, 312 B2 Euro 6, 312 B5, 330 A1, 5526963, 55283775, 955 B2  1.3 cc R4	Fiat Albea, Doblò, Fiorino, Grande Punto, Linea, 500, Palio, Panda, Punto  Alfa Romeo, MiTo  Lancia Musa, Ypsilon  Suzuki Swift, SX4, Splach  TATA Indica Vista, Manza		  450 gr   Torque : 45 Nm 2nd Torque Option : 20 Nm + 40 °	Connecting Rod STD  Connecting Rod SEMI  Bushing Bimetal Locked-Straight  Bolt - 10.9 M8x1 L: 38 mm  Con. Rod OEM : 735 012 29, 552 086 24	<b>BMY1401</b> 1 pc.24x10x4cm  <b>BMY1401SEMI</b> 1 pc.24x10x4cm  <b>BMY1401B</b> 4 pcs.10x6x4cm  <b>BMY1401CB</b> 8 pcs.10x6x4cm	
<b>2</b>						
Fiat 1.9 D JTD 182.B9, 188 A2, 939 A2, 192.A5, 192 B1, 932 A2, 937 A1, 937 A2, 937 A3, 937 A4, 937 A5, 937 A6, 937 A7, 937 A8, 939 A1, 939 A2, 939 A7, 939 A8, AR 32302 AR 37101  Opel Z19DT/H  1.9 cc R4	Alfa Romeo 146,147,159,GT  Cadillac BLS  Fiat Doblo, Bravo, Punto Fiat Croma, Marea, Stilo  Lancia Delta, Lybra, Musa  Opel Signum, Vectra C, Zafira B Saab 9-3, 9-5, Suzuki SX4		  760 gr   Torque : 60 Nm	Connecting Rod STD  Connecting Rod SEMI  Bushing Bimetal Locked-Straight  Bolt - 10.9 M9x1 L: 46 mm  Con. Rod OEM : 467 689 51	<b>BMY1402</b> 1 pc.24x10x4cm  <b>BMY1402SEMI</b> 1 pc.24x10x4cm  <b>BMY1402B</b> 4 pcs.10x6x4cm	
<b>3</b>						
Fiat 1.6 JTD 198 A2, 198 A3, 198 A6, 199 B5, 263 A4, 940 A3, 263 A3 Euro 5, 263 A7/A8/A9 350 A2/A3, 955 A3, 844 A3, 944 A3, 955 A4  1.6 cc R4	Alfa Romeo Mito, Giulietta Fiat 500L, Bravo, Doblò, Fiat Grande, Punto, Idea, Fiat Egea, Tipo, Fiat Linea Jeep Renegade Lancia Delta, Musa Opel Combo D Suzuki Vitara, SX4 S-Cross		  645 gr   Torque : 60 Nm	Connecting Rod STD  Connecting Rod SEMI  Bushing Bimetal Locked-Straight  Bolt - 10.9 M9x1 L: 46 mm  Con. Rod OEM : 552 288 71	<b>BMY1403</b> 1 pc.24x10x4cm  <b>BMY1403SEMI</b> 1 pc.24x10x4cm  <b>BMY1403B</b> 4 pcs.10x6x4cm	



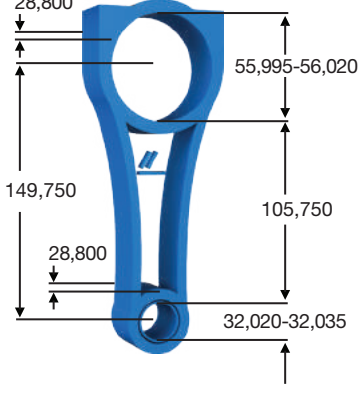

Engine Type	Models	Picture	Sizes (mm)	Products	BMY Reference
<p><b>4</b></p> <p>Fiat 2.0 JTD 263A1 D20AA B182 B900, Euro 5, 844 A2, 939 B3, 939 B4, 940 A4, 940 A7 Euro 5, 940 A8 Euro 5, 198 A5, 198 A5, 250 A1 Euro 5, 250 A2, 263 A1 Euro 5, 844 A2, 939 B5, 198 A5, 844 A2</p> <p>Opel/Vauxhall A20DTC, A20DTH, A20DTJ, A20DTL, Y20DTJ, Z20DTJ</p> <p>2.0 cc</p> <p>R4</p>	<p>Fiat Freemont, Doblo, Bravo Lancia/Chrysler Delta</p> <p>Alfa Romeo Brera, Spider, 159, Giulietta</p> <p>Opel Insignia, Astra</p>		<p>740 gr   Torque : 60 Nm 2nd Torque Option : 25 Nm + 60 °</p>	<p>Connecting Rod <b>STD</b></p> <p>Connecting Rod <b>SEMI</b></p> <p>Bushing Bimetal <b>Locked-Straight</b></p> <p>Bolt - 10.9 M9x1 L: 46 mm</p>	<p><b>BMY1404</b> 1 pc.24x10x4cm</p> <p><b>BMY1404SEMI</b> 1 pc.24x10x4cm</p> <p><b>BMY1504B</b> 4 pcs.10x6x4cm</p> <p><b>BMY0805B</b> 8 pcs.10x6x4cm</p> <p>Con. Rod OEM: 55198189 <b>With Bearing Lug</b> <b>(for without Lug BMY1504)</b></p>
<p><b>5</b></p> <p>Fiat - Iveco 2.3 JTD F1AE</p> <p>2.3 cc</p> <p>R4</p>	<p>Fiat Ducato</p> <p>Iveco Daily</p> <p>UAZ Patriot</p> <p>Karsan Jest/J10</p>		<p>1140 gr   Torque : 80 Nm 2nd Torque Option : 40 Nm + 60 °</p>	<p>Connecting Rod <b>STD</b></p> <p>Connecting Rod <b>SEMI</b></p> <p>Bushing Bimetal <b>Locked-Straight</b></p> <p>Bolt - 10.9 M10x1,25 L: 49</p>	<p><b>BMY1405</b> 1 pc.30x12x6cm</p> <p><b>BMY1405SEMI</b> 1 pc.30x12x6cm</p> <p><b>BMY1405B</b> 4 pcs.10x6x4cm</p> <p><b>BMY1405CB</b> 8 pcs.10x6x4cm</p> <p>Con. Rod OEM : 504 341 501 504 057 276</p>
<p><b>6</b></p> <p>Fiat - Iveco 3.0 JTD F1CE</p> <p>Mitsubishi 4P10-7AT/T2/ T4/T6</p> <p>3.0 cc</p> <p>R4</p>	<p>Fiat Ducato</p> <p>Iveco Daily, Massif</p> <p>Citroen Jumper</p> <p>Mitsubishi Fuso Canter 8B/9BL</p>		<p>1340 gr   Torque : 80 Nm</p>	<p>Connecting Rod <b>STD</b></p> <p>Connecting Rod <b>SEMI</b></p> <p>Bushing Bimetal <b>Locked-Straight</b></p> <p>Bolt - 10.9 M10x1,25 L:49 mm</p>	<p><b>BMY1406</b> 1 pc.30x12x6cm</p> <p><b>BMY1406SEMI</b> 1 pc.30x12x6cm</p> <p><b>BMY1406B</b> 4 pcs.10x6x4cm</p> <p>Con. Rod OEM : 504 341 496</p>





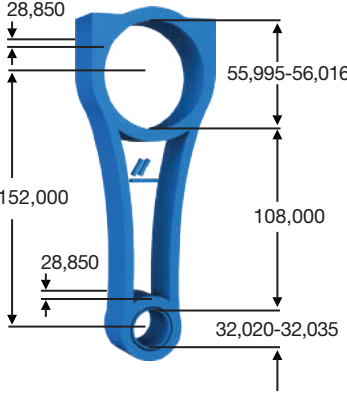

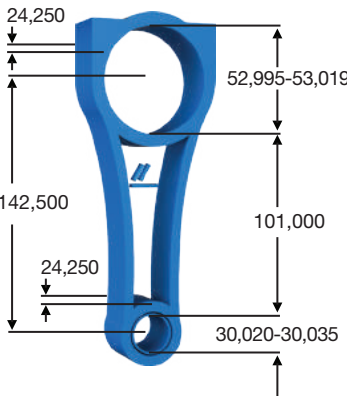

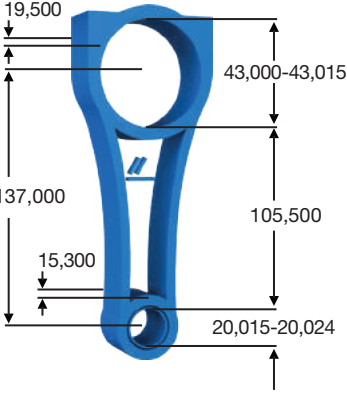

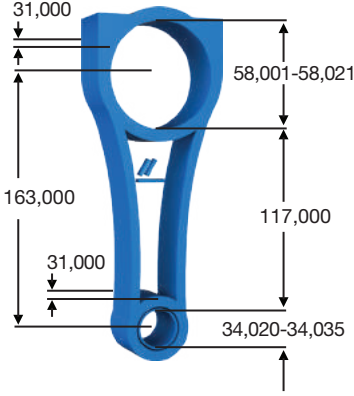





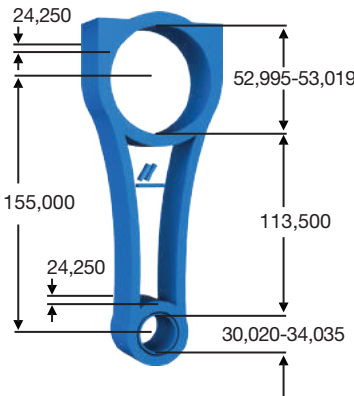



Engine Type	Models	Picture	Sizes (mm)	Products	BMY Reference
<b>7</b> Fiat-Iveco F1AF-F1AG  2.3 cc  R4  Euro 6	Fiat Ducato,  Iveco Daily		<p>27,550 59,830-59,850 146,000 100,580 27,550 31,020-31,040</p> <p>985 gr   Torque : 60 Nm</p>	Connecting Rod STD <b>BMY1407</b> 1 pc.30x12x6cm	Connecting Rod SEMI <b>BMY1407SEMI</b> 1 pc.30x12x6cm
				Bushing Bimetal Locked-Straight <b>BMY1407B</b> 4 pcs.10x6x4cm	Bolt - 10.9 M9x1 L:46 mm <b>BMY0805CB</b> 8 pcs.10x6x4cm
<p>Con. Rod OEM :5801841535, 5801842210, 5802116073</p>					
<b>8</b> Fiat/Alfa Romeo/ Dodge 169.A3, 192.B2, 198.A1, 198.A4, 198.A7, 199.A6, 199.A7, 199.A8, 312.A1, 843 A1, 350 A1, 940.B7, 955.A2, 955.A6, 955.A8, 955.A9, 178.F3, 310.A2, EAF 55263623, 55263624  1.4 cc  R4	Fiat Punto, 500, 500C, 500L, 500X, Doblo, Tipo, Ideo, Stilo, Egea, 124 Spider, Brava  Alfa Romeo Mito, Giulietta  Dodge Dart		<p>18,000 45,128-45,138 129,050 97,500 21,650 17,970-17,974</p> <p>408 gr   Torque : 45 Nm 2nd Torque Option : 20 Nm + 40 °</p>	Connecting Rod STD - Tapered <b>BMY1408</b> 1 pc.24x10x4cm	Connecting Rod SEMI - Tapered <b>BMY1408SEMI</b> 1 pc.24x10x4cm
				Bushing Bimetal Locked-Straight <b>BMY1408B</b> 4 pcs.10x6x4cm	Bolt - 10.9 M8x1 L: 38 mm
<p>Con. Rod OEM : 46743870, 46740345</p>					
<b>9</b> VM Motori A630 DOHC, A630HP, L630  Chrysler/Jeep/ Lancia EXF, EXL, EXN, M664 CRD/TD  Maserati A630HP, M15746D  V6 3.0 (2987) cc	Jeep Grand Cherokee IV (WK, WK2), Commander  Chrysler 300  Maserati Ghibli III, Quattroporte VI, Levante  Lancia Thema  Ram 1500		<p>22,650 71,000-71,021 162,150 111,650 25,800 30,020-30,035</p> <p>720 gr   Torque : 70 Nm</p>	Connecting Rod STD <b>BMY1409</b> 1 pc.30x12x6cm	Connecting Rod SEMI <b>BMY1409SEMI</b> 1 pc.30x12x6cm
				Bushing Bimetal Locked-Straight <b>BMY1409B</b> 3 pcs.10x6x4cm	Bolt - 10.9 M9x1 L: 50 mm <b>BMY1409CB</b> 12 pcs.10x6x4cm
<p>Con. Rod OEM : 681 472 33AA</p>					



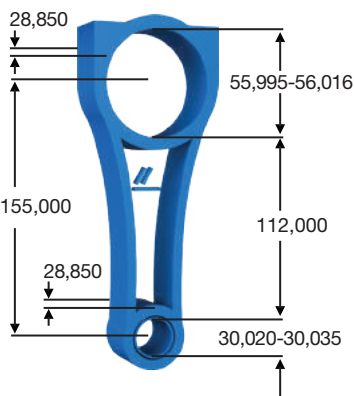





Engine Type	Models	Picture	Sizes (mm)	Products	BMY Reference
<b>10</b> Fiat Sofim 8140/ S8U,89U  2.5 cc R4	Fiat Ducato, Croma  Peugeot Boxer Renault Master, Traffic  Lancia Thema		  1320gr   Torque : 80 Nm	Connecting Rod STD  Connecting Rod SEMI  Bushing Bimetal Locked-Straight  Bolt - 10.9 M10x1,25 L: 58 mm	<b>BMY0802</b> 1 pc.24x10x4cm  <b>BMY0802SEMI</b> 1 pc.24x10x4cm  <b>BMY0803B</b> 4 pcs.10x6x4cm
  				  	
<b>11</b> Fiat Sofim 8140/ S8W/S9W  2.8 cc R4	Fiat Ducato  Iveco Daily  Renault Master, Mascott  Opel Movano  Citroën Jumper  Peugeot Boxer		  720 gr   Torque : 70 Nm	Connecting Rod STD  Connecting Rod SEMI  Bushing Bimetal Locked-Straight  Bolt - 10.9 M10x1,25 L: 58 mm	<b>BMY0803</b> 1 pc.24x10x4cm  <b>BMY0803SEMI</b> 1 pc.24x10x4cm  <b>BMY0803B</b> 4 pcs.10x6x4cm
  				  	



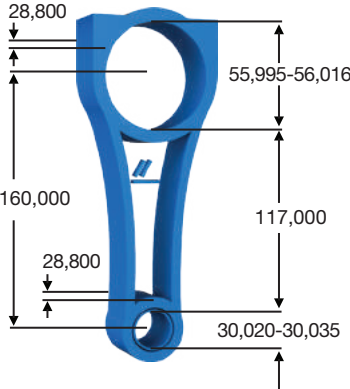
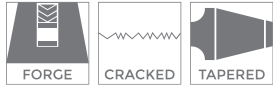

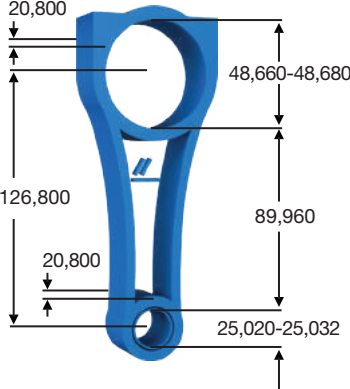
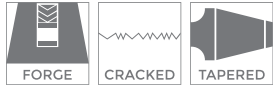

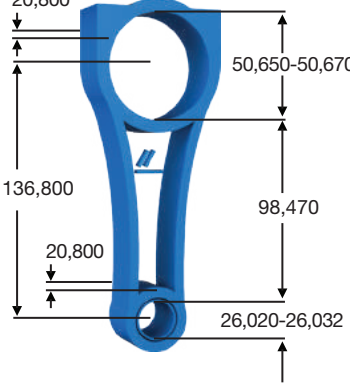
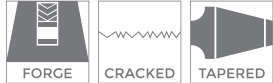

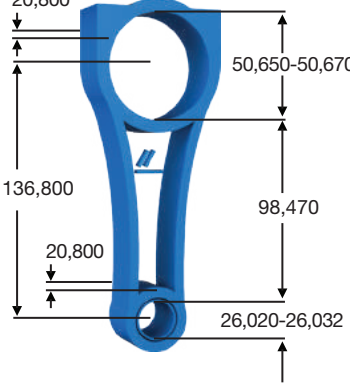
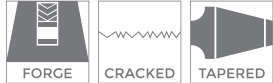

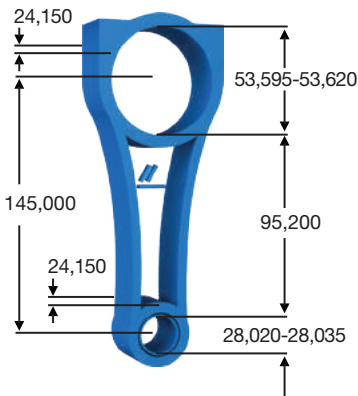

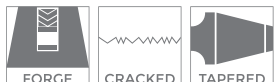

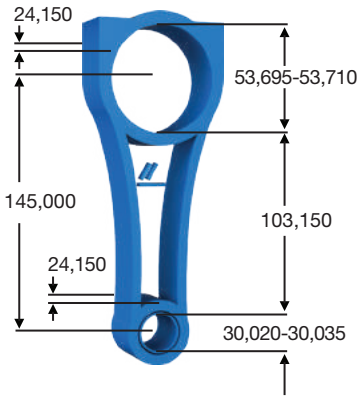
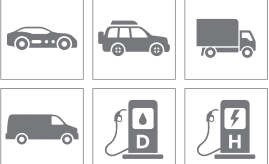
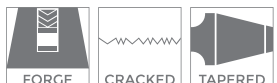

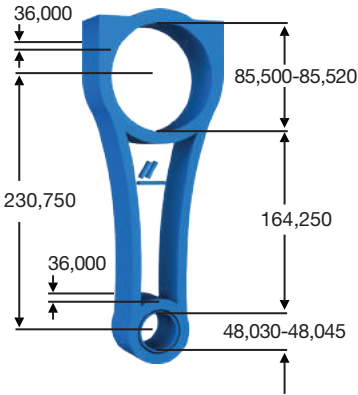





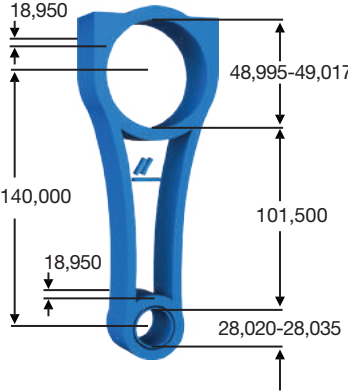





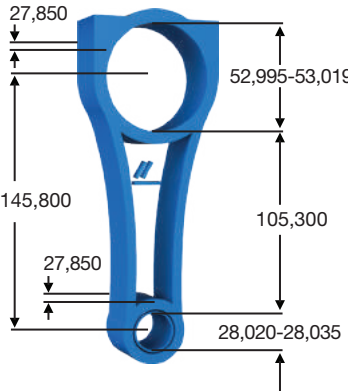





Engine Type	Models	Picture	Sizes (mm)	Products	BMY Reference
<b>1</b> Ford HCPA, HCPB, P9PA, P9PC, P9PD, R3PA 90ps  RWPD 110ps  1.8 cc  R4	Ford Connect, Mondeo		 <p>695 gr   Torque : 60 Nm            2nd Torque Option :            30 Nm+100 °</p>	Connecting Rod STD  Connecting Rod SEMI  Bushing Bimetal Locked-Straight  Bolt - 10.9 M9x1 L:46 mm	<b>BMY1101</b> 1 pc.24x10x4cm  <b>BMY1101SEMI</b> 1 pc.24x10x4cm  <b>BMY1101B</b> 4 pcs.10x6x4cm  <b>BMY0805CB</b> 8 pcs.10x6x4cm
  	  				
<b>2</b> Ford FYJA FYJB  1.6 cc  FYDA, FYDB, FYDC, FYDD, FYDH, ZETEC  R4	Ford Focus Mondeo C-Max Fusion  Mazda 2		 <p>400 gr   Torque : 50 Nm            2nd Torque Option :            15 Nm + 90 °</p>	Connecting Rod STD  Bolt - 10.9 M8x1 L: 38 mm	<b>BMY1102</b> 1 pc.24x10x4cm  <b>BMY0806CB</b> 2 pcs.10x6x4cm
 	  				
<b>3</b> Ford V184 D2FA H9FA H9FB JXFA  2.4 cc  R4	Ford Transit V184		 <p>950 gr   Torque : 80 Nm</p>	Connecting Rod STD  Connecting Rod SEMI  Bushing Bimetal Locked-Straight  Bolt - 10.9 M10 x1,25 L:49	<b>BMY1103</b> 1 pc.24x10x4cm  <b>BMY1103SEMI</b> 1 pc.24x10x4cm  <b>BMY1103B</b> 4 pcs.10x6x4cm
  	  				

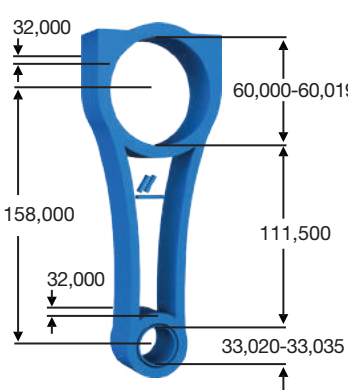









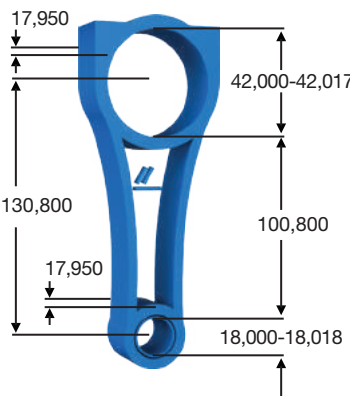









Engine Type	Models	Picture	Sizes (mm)	Products	BMY Reference
<p><b>4</b></p> <p>Ford ENSA, SAFA, SAFB, SA2R, SA2S, SA2W / 4x4 200ps</p> <p>3.2 cc</p> <p>R5</p>	<p>Ford Ranger, Transit</p>		 <p>1110 gr   Torque : 80 Nm</p>	<p>Connecting Rod STD - Tapered</p> <p>Connecting Rod SEMI - Tapered</p> <p>Bushing Bimetal Locked-Straight</p> <p>Bolt - 10.9 M10 x1,25 L:49</p> <p>Con. Rod OEM : 7C16 6200 BAB, 7C18 6200 BAA</p>	<p><b>BMY1105</b> 1 pc.24x10x4cm</p> <p><b>BMY1105SEMI</b> 1 pc.24x10x4cm</p> <p><b>BMY1103B</b> 4 pcs.10x6x4cm</p>
<p><b>5</b></p> <p>Ford BCCC, BJFA/B, YLCB, YLDA, YLF6, YLFA/B, YLFS, YMFB, YMF6, YMFA/B, YMFS, YMHA, YMRA, YMR6, YNCA, YNF6, YNFA/B, YNFS, YNRA</p> <p>4x2, 4x4 FWD, RWD</p> <p>EcoBlue, EcoBlue BiTurbo</p> <p>2.0 cc - R4</p> <p>Euro 6</p>	<p>S-Max, Galaxy, Transit Custom, Tourneo Custom V362/V363, Panther C Ranger</p>		 <p>715 gr   Torque : 60 Nm</p>	<p>Connecting Rod STD</p> <p>Connecting Rod SEMI</p> <p>Bushing Bimetal Locked-Straight</p> <p>Bolt - 10.9 M9x1 L:46 mm</p> <p>OEM : RFGK206205BA, GK2Q6205BA</p>	<p><b>BMY1106</b> 1 pc. 24x10x4cm</p> <p><b>BMY1106SEMI</b> 1 pc. 24x10x4cm</p> <p><b>BMY1106B</b> 4 pcs.10x6x4cm</p> <p><b>BMY0805CB</b> 8 pcs.10x6x4cm</p>
<p><b>6</b></p> <p>Ford Ecoboost M1CA/B M1BC, M1DA, M1JA, M1JC/E/H, M2DA M2GA/B, SFCAB/C/D, SFDA, SFJA/B SFJC/D, XMJA/B, YYJA/B/C/D</p> <p>1.0 cc</p> <p>R3</p>	<p>B-Max, C-Max II, Ecosport, Fiesta VI, Focus III, Grand C-Max, Mondeo V,</p> <p>Tourneo Connect/ Courier,</p> <p>Transit Connect/ Courier</p>		 <p>390 gr   Torque : 45 Nm 2nd Torque Option : 20 Nm + 40° Nm</p>	<p>Connecting Rod STD</p> <p>Connecting Rod SEMI</p> <p>Bushing Bimetal Locked-Straight</p> <p>Bolt - 10.9 M8x1 L:38 mm</p> <p>Con. Rod OEM : CM5G 6205 FA, CM5G 6205 EC</p>	<p><b>BMY1107</b> 1 pc.24x10x4cm</p> <p><b>BMY1107SEMI</b> 1 pc.24x10x4cm</p> <p><b>BMY1107B</b> 4 pcs. 10x6x4cm</p> <p><b>BMY1401CB</b> 8 pcs. 10x6x4cm</p>









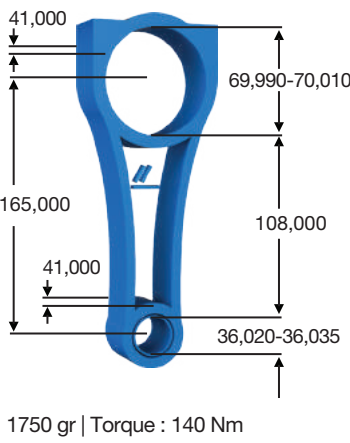

Engine Type	Models	Picture	Sizes (mm)	Products	BMY Reference
<p><b>7</b></p> <p>Ford/Mazda 6M34 WL-C, WLAA 143ps 2.5 cc</p> <p>Ford/Mazda WEC UNY0E3 3.0 cc</p> <p>2006 - ...</p> <p>R4</p>	<p>Ford Ranger (ET), Everest, Endeavour</p> <p>Mazda BT-50 Pick-Up</p>		 <p>1160 gr   Torque : 80 Nm</p>	<p>Connecting Rod STD - Tapered</p> <p>Connecting Rod SEMI - Tapered</p> <p>Bushing Bimetal Locked-Straight</p> <p>Bolt - 10.9 M10 x1,25 L:49</p>	<p><b>BMY1108</b> 1 pc.24x10x4cm</p> <p><b>BMY1108SEMI</b> 1 pc.24x10x4cm</p> <p><b>BMY1108B</b> 4 pcs.10x6x4cm</p> <p>Con. Rod OEM : 6M34 6200 AB, 4943884</p>
 	  				
<p><b>8</b></p> <p>Ford BKFA, BKFB, BKFC, BKFD, BKRA, BKR B EcoBlue</p> <p>Euro 6.2</p> <p>2.0cc</p> <p>R4</p>	<p>S-Max, Galaxy, Transit Custom, Tourneo Custom V362/V363, Panther C Ranger 4x2, 4x4 FWD, RWD</p>		 <p>740 gr   Torque : 60 Nm</p>	<p>Connecting Rod STD</p> <p>Connecting Rod SEMI</p> <p>Bushing Bimetal Locked-Straight</p> <p>Bolt - 10.9 M9x1 L:46 mm</p>	<p><b>BMY1109</b> 1 pc. 24x10x4cm</p> <p><b>BMY1109SEMI</b> 1 pc. 24x10x4cm</p> <p><b>BMY1106B</b> 4 pcs.10x6x4cm</p> <p><b>BMY0805CB</b> 8 pcs.10x6x4cm</p> <p>Con. Rod OEM : HG9Q6205AA, RFHG9Q6205AA</p>
   	  				
<p><b>9</b></p> <p>Ford CVRA, CVRB, CVRC 155ps, CYFA, CYFB, CYFC, CYRA, CYRB 125ps, DRFA, DRFB, DRFC, DRFF, DRFG, DRF5, 100ps PGFA, PGFB, UHFA, UHFB, UHFC 140ps</p> <p>2.2 cc</p> <p>R4</p>	<p>Ford Transit, Mondeo</p> <p>Peugeot Boxer</p> <p>Fiat Ducato</p> <p>Citroen Jumper</p>		 <p>882 gr   Torque : 60 Nm 2nd Torque Option : 30 Nm+100 °</p>	<p>Connecting Rod STD</p> <p>Connecting Rod SEMI</p> <p>Bushing Bimetal Locked-Straight</p> <p>Bolt - 10.9 M9x1 L:46 mm</p>	<p><b>BMY0804</b> 1 pc.24x10x4cm</p> <p><b>BMY0804SEMI</b> 1 pc.24x10x4cm</p> <p><b>BMY0804B</b> 4 pcs. 10x6x4cm</p> <p><b>BMY0805CB</b> 8 pcs. 10x6x4cm</p> <p>OEM : 9C1Q 6200 ABA - CK2Q 6200 AAA/ABA/ACA - BB3Q 6200 AAA, BB3Q 6200 AAA, RFBB3Q 6200 AA, QC1Q 6200 ABA FINIS: 1717559, T275156</p>
  	  				

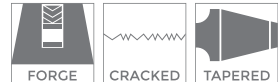
Engine Type	Models	Picture	Sizes (mm)	Products	BMY Reference									
<p><b>10</b></p> <p>Ford PGFA, PGFB 140ps</p> <p>P8FA, P8FB 85ps</p> <p>QWFA 130ps</p> <p>QVFA 110ps</p> <p>2.2 cc</p> <p>R4</p> 	<p>Ford Transit, Mondeo</p> <p>Peugeot Boxer</p> <p>Fiat Ducato</p> <p>Citroen Jumper</p>		 <p>873 gr   Torque : 60 Nm 2nd Torque Option : 30 Nm+100 °</p>	<p>Connecting Rod STD <b>BMY0805</b> 1 pc.24x10x4cm</p> <p>Connecting Rod SEMI <b>BMY0805SEMI</b> 1 pc.24x10x4cm</p> <p>Bushing Bimetal Locked-Straight <b>BMY0804B</b> 4 pcs.10x6x4cm</p> <p>Bolt - 10.9 M9x1 L:46 mm <b>BMY0805CB</b> 8 pcs.10x6x4cm</p> <p>Con. Rod OEM : 1S7Q 6200 CBA FIN: 1614885, 137616, 1377618, 137620, 1548564</p> 	<p><b>11</b></p> <p>Ford DLD-414</p> <p>1.4 cc</p> <p>R4</p> 	<p>Ford Fiesta, Fusion</p> <p>Peugeot 206, 207, 1007</p> <p>Citroen C1, C2, C3, Xsara</p> <p>Mazda 2</p> <p>Suzuki Liana</p> <p>Toyota Aygo</p>		 <p>500 gr   Torque : 45 Nm 2nd Torque Option : 5 Nm + 10 Nm + 130 °</p>	<p>Connecting Rod STD <b>BMY0806</b> 1 pc.24x10x4cm</p> <p>Connecting Rod SEMI <b>BMY0806SEMI</b> 1 pc.24x10x4cm</p> <p>Bushing Bimetal Locked-Straight <b>BMY0806B</b> 4 pcs.10x6x4cm</p> <p>Bolt - 10.9 M7x1 L: 38 mm <b>BMY0806CB</b> 8 pcs.10x6x4cm</p> <p>Con. Rod OEM : 7S6Q 6200 AC FIN: 1509473</p> 	<p><b>12</b></p> <p>Ford DLD-416</p> <p>Ford AEDA, UGJA, UGJC</p> <p>1.5 - 1.6 cc</p> <p>R4</p> 	<p>Ford C-Max, Focus, Fiesta</p> <p>Peugeot 207, 307, 308, 407, Partner, 508</p> <p>Citroen C3, C4, Berlingo</p> <p>MINI Cooper D</p> <p>Mazda 2, 3</p> <p>Volvo C30, S40, V50/60, S60</p> <p>Suzuki SX4</p>		 <p>600 gr   Torque : 45 Nm 2nd Torque Option : 5 Nm + 10 Nm + 130 °</p>	<p>Connecting Rod STD <b>BMY0807</b> 1 pc.24x10x4cm</p> <p>Connecting Rod SEMI <b>BMY0807SEMI</b> 1 pc.24x10x4cm</p> <p>Bushing Bimetal Locked-Straight <b>BMY0807B</b> 4 pcs.10x6x4cm</p> <p>Bolt - 10.9 M7x1 L: 38 mm <b>BMY0806CB</b> 8 pcs.10x6x4cm</p> <p>Con. Rod OEM : 7M5Q 6200 AD/AE FINIS: 1569495</p> 
<p><b>12</b></p> <p>Ford DLD-416</p> <p>Ford AEDA, UGJA, UGJC</p> <p>1.5 - 1.6 cc</p> <p>R4</p> 	<p>Ford C-Max, Focus, Fiesta</p> <p>Peugeot 207, 307, 308, 407, Partner, 508</p> <p>Citroen C3, C4, Berlingo</p> <p>MINI Cooper D</p> <p>Mazda 2, 3</p> <p>Volvo C30, S40, V50/60, S60</p> <p>Suzuki SX4</p>		 <p>600 gr   Torque : 45 Nm 2nd Torque Option : 5 Nm + 10 Nm + 130 °</p>	<p>Connecting Rod STD <b>BMY0807</b> 1 pc.24x10x4cm</p> <p>Connecting Rod SEMI <b>BMY0807SEMI</b> 1 pc.24x10x4cm</p> <p>Bushing Bimetal Locked-Straight <b>BMY0807B</b> 4 pcs.10x6x4cm</p> <p>Bolt - 10.9 M7x1 L: 38 mm <b>BMY0806CB</b> 8 pcs.10x6x4cm</p> <p>Con. Rod OEM : 7M5Q 6200 AD/AE FINIS: 1569495</p> 										

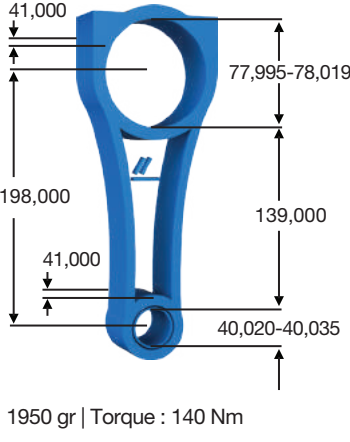

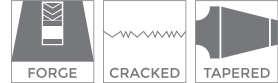

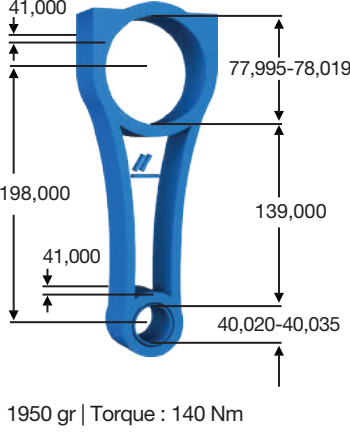
Engine Type	Models	Picture	Sizes (mm)	Products	BMY Reference
<b>13</b> Ford Duratorq TDCI AZBA/AZBC/AZWA/AZWC/G6DA/G6DD/G6DE/G6DG/IXDA/KLBA/LPBA/QXBA/QXWB/QXWC/UFBA  2.0 cc R4	Ford Focus, C-Max, Focus, S-Max, Galaxy, Mondeo, Kuga  Peugeot Partner, 307, 407, 607, 807, 308, 508  Volvo C30, C70, S40, V50, S80, V70		 <p>780 gr   Torque : 60 Nm</p>	Connecting Rod STD <b>BMY0810</b> 1 pc.24x10x4cm  Connecting Rod SEMI <b>BMY0810SEMI</b> 1 pc.24x10x4cm  Bushing Bimetal Locked-Straight <b>BMY0810B</b> 4 pcs.10x6x4cm  Bolt - 10.9 M9x1 L:56 mm  Con. Rod OEM : 0603 90 0603 A6   3M5Q 6200 BC	 
<b>14</b> Ford - Peugeot DW10CTED4, DW10FUD RHH, RHE, RH02  2.0 cc R4	Peugeot 308, 407, 508, 3008, 5008, RCZ, Partner  Citroen C4, C5, DS4, DS5, Berlingo, Jumpy, Xsara  Ford Focus, CMax, Transit		 <p>790 gr   Torque : 60 Nm</p>	Connecting Rod STD <b>BMY0811</b> 1 pc.24x10x4cm  Connecting Rod SEMI <b>BMY0811SEMI</b> 1 pc.24x10x4cm  Bushing Bimetal Locked-Straight <b>BMY0811B</b> 4 pcs.10x6x4cm  Bolt - 10.9 M9x1 L:46 mm  Con. Rod OEM : 0603 C5 1613238180, 9M5Q 6200 AC, 1406651180, 1606651180	 
<b>15</b> Ford NHDD, 9.0L EcoTorq  Euro 6  9.0 (8974) cc R6	Ford Cargo 1835, 2535, 3235, 1833, 2533, 2633, 3233		 <p>2760 gr</p>	Connecting Rod STD <b>BMY1151</b> 1 pc.48x15x6cm  Connecting Rod SEMI <b>BMY1151SEMI</b> 1 pc.48x15x6cm  Bushing Bimetal Locked-Straight <b>BMY1151B</b> 4 pcs.10x6x4cm  Bolt - 10.9 M9x1 L:46 mm <b>BMY1151CB</b> 8 pcs.10x6x4cm  Con. Rod OEM : 6C46 6205 AB	 

Engine Type	Models	Picture	Sizes (mm)	Products	BMY Reference
<p><b>1</b></p> <p>Hyundai - Kia D4FA/B D3FA, D4FC</p> <p>1.2 - 1.5 cc</p> <p>R3 - R4</p>	<p>Hyundai Era, Accent, Getz, i10, i20, i30</p> <p>Kia Cerato, Rio Ceed</p>		 <p>18,950 48,995-49,017 140,000 101,500 18,950 28,020-28,035</p> <p>557 gr   Torque : 45 Nm 2nd Torque Option : 12.7 Nm + 90 °</p>	<p>Connecting Rod STD <b>BMY0601</b> 1 pc.24x10x4cm</p> <p>Connecting Rod SEMI <b>BMY0601SEMI</b> 1 pc.24x10x4cm</p> <p>Bushing Bimetal Locked-Straight <b>BMY0601B</b> 4 pcs.10x6x4cm</p> <p>Bolt - 10.9 M7x1 L: 38 mm <b>BMY0806CB</b> 8 pcs.10x6x4cm</p> <p>Con. Rod OEM : 23510 2A701 23510 2A001, 23510 2A600, 23510 2A750</p>	    
<p><b>2</b></p> <p>Hyundai - Kia D3EA - D4EA -D4EB</p> <p>1.5 - 2.0 - 2.2cc</p> <p>R3 - R4 - R5</p> <p>Opel-Chevrolet Z20DMH, Z20S, Z20DM</p> <p>2.0 cc</p> <p>R4</p>	<p>Hyundai Accent, Elntra, Tuscon, Santafe CRDI, i30</p> <p>Kia Cee'd, Sportage, Cerato</p> <p>Mitsubishi Colt</p>		 <p>27,850 52,995-53,019 145,800 105,300 27,850 28,020-28,035</p> <p>885 gr   Torque : 50 Nm</p>	<p>Connecting Rod STD <b>BMY0602</b> 1 pc.24x10x4cm</p> <p>Connecting Rod SEMI <b>BMY0602SEMI</b> 1 pc.24x10x4cm</p> <p>Bushing Bimetal Locked-Straight <b>BMY0602B</b> 4 pcs.10x6x4cm</p> <p>Bolt - 10.9 M8x1 L: 47mm</p> <p>Con. Rod OEM : 23510 27300 23510 27000, 23510 27010, 23510 27400, 23510 27410, 96440175, 4807976</p>	     
<p><b>3</b></p> <p>Hyundai - KIA Dodge D4CB, D4BC</p> <p>2.5 CRDI</p> <p>R4</p>	<p>Hyundai H350, H100, H1, Porter, Starex</p> <p>Kia Bongo, K2500, Sorento</p> <p>Dodge H100</p>		 <p>32,000 60,000-60,019 158,000 111,500 32,000 33,020-33,035</p> <p>1188gr   Torque : 80 Nm</p>	<p>Connecting Rod STD <b>BMY0603</b> 1 pc.24x10x4cm</p> <p>Connecting Rod SEMI <b>BMY0603SEMI</b> 1 pc.24x10x4cm</p> <p>Bushing Bimetal Locked-Straight <b>BMY0603B</b> 4 pcs.10x6x4cm</p> <p>Bolt - 10.9 M10x1,25 L: 49mm</p> <p>Con. Rod OEM : 23510-4A000, 235104A500, 235104A710</p>	      



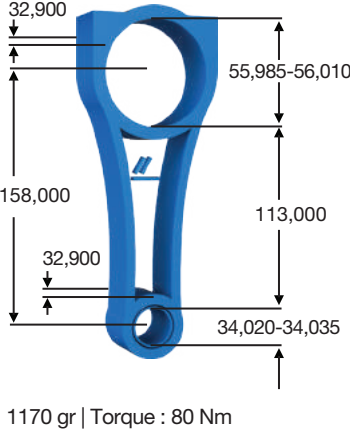

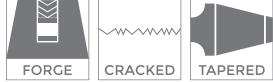



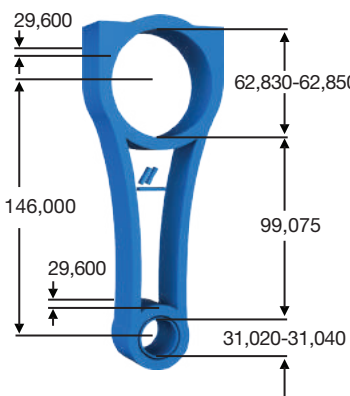

Engine Type	Models	Picture	Sizes (mm)	Products	BMY Reference
<p><b>4</b></p> <p>Hyundai/Kia G4LC</p> <p>1.4 cc</p> <p>R4</p> <p>G3LA/B3LA</p> <p>1.0cc</p> <p>R4</p>	<p>i10, i20, i30, Accent, Solaris, HB20</p> <p>Picanto, Rio, Ceed, Stonic,</p>		<p>17,950</p> <p>42,000-42,017</p> <p>130,800</p> <p>100,800</p> <p>17,950</p> <p>18,000-18,018</p> <p>285 gr   Torque : 45Nm 2nd Torque Option : 12.7Nm+90°</p>	<p>Connecting Rod STD</p> <p>Bolt - 10.9 M7x1 L: 38mm</p> <p>Con. Rod OEM : 23510-04010, 23510-04030</p>	<p><b>BMY0604</b> 1 pc.24x10x4cm</p> <p><b>BMY0806CB</b> 8 pcs.10x6x4cm</p>
  	  				
<p><b>5</b></p> <p>Hyundai D4BF, D4BB, D4BH</p> <p>Mitsubishi 4D55T, 4D56</p> <p>2.5 cc</p> <p>R4</p>	<p>Hyundai Starex/ H100</p> <p>Mitsubishi L200/300</p>		<p>29,800</p> <p>55,995-56,020</p> <p>158,000</p> <p>115,500</p> <p>32,000</p> <p>29,020-29,035</p> <p>1040 gr   Torque : 60 Nm</p>	<p>Connecting Rod STD</p> <p>Connecting Rod SEMI</p> <p>Bushing Bimetal Locked-Straight</p> <p>Bolt - 10.9 M9x1 L:46 mm</p> <p>Con. Rod OEM : MD371001 23510 42010</p>	<p><b>BMY1303</b> 1 pc.24x10x4cm</p> <p><b>BMY1303SEMI</b> 1 pc.24x10x4cm</p> <p><b>BMY1303B</b> 4 pcs.10x6x4cm</p>
  	  				
<p><b>6</b></p> <p>Hyundai - Mitsubishi 4D56U 4D56T</p> <p>2.5 cc</p> <p>R4</p>	<p>Hyundai H100 (2015-...)</p> <p>Mitsubishi L200/300</p>		<p>29,800</p> <p>59,995-60,020</p> <p>158,000</p> <p>112,000</p> <p>34,000</p> <p>32,020-32,035</p> <p>1040 gr   Torque : 60 Nm</p>	<p>Connecting Rod STD</p> <p>Connecting Rod SEMI</p> <p>Bushing Bimetal Locked-Straight</p> <p>Bolt - 10.9 M9x1 L: 46 mm</p> <p>Con. Rod OEM : 1115 A345</p>	<p><b>BMY1305</b> 1 pc.24x10x4cm</p> <p><b>BMY1305SEMI</b> 1 pc.24x10x4cm</p> <p><b>BMY1305B</b> 4 pcs.10x6x4cm</p>
  	  				



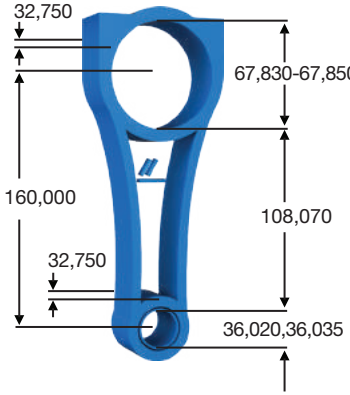



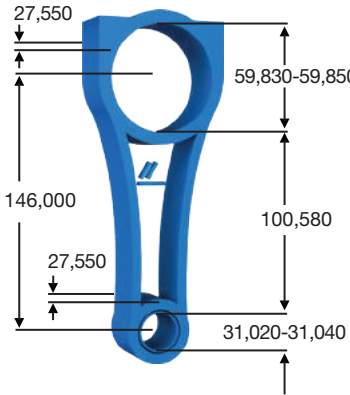



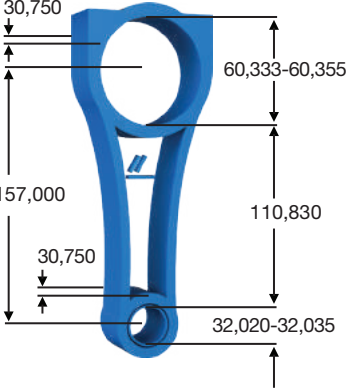







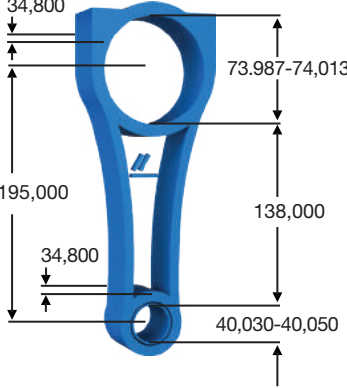





Engine Type	Models	Picture	Sizes (mm)	Products	BMY Reference
<b>1</b> Isuzu 4HF1 4.3 cc R4	NKR66, NPR66, Champion MD23, MD25, MD27			Connecting Rod STD	<b>BMY0401</b> 1 pc.30x12x6cm
				Connecting Rod SEMI	<b>BMY0401SEMI</b> 1 pc.30x12x6cm
				Bushing Bimetal Locked-Straight	<b>BMY0401B</b> 4 pcs.10x6x4cm
				Bolt - 10.9 M13x1,25 L:58	
				Con. Rod OEM : 897135032351	
					
<b>2</b> Isuzu 4HE1-T 4.7 cc R4	NQR, NQR3D, NPR, NPS4x4, Turkuaz, Euro II/ III			Connecting Rod STD	<b>BMY0402</b> 1 pc.30x12x6cm
				Connecting Rod SEMI	<b>BMY0402SEMI</b> 1 pc.30x12x6cm
				Bushing Bimetal Locked-Straight	<b>BMY0402B</b> 4 pcs. 10x6x4cm
				Bolt - 12.9 M13x1,25 L: 57	<b>BMY0402CB</b> 8 pcs. 10x6x4cm
				Con. Rod OEM: 8943917911, 898018425251	
					
<b>3</b> Isuzu 4HK1-6HK1-TCS 5.2 cc R4 - R6	NQR86, Turkuaz Euro III/IV C.Rail			Connecting Rod STD	<b>BMY0403</b> 1 pc.30x12x6cm
				Connecting Rod SEMI	<b>BMY0403SEMI</b> 1 pc.30x12x6cm
				Bushing Bimetal Locked-Straight	<b>BMY0402B</b> 4 pcs. 10x6x4cm
				Bolt - 12.9 M13x1,25 L: 57	<b>BMY0402CB</b> 8 pcs. 10x6x4cm
				Con. Rod OEM : 894399661251	
					

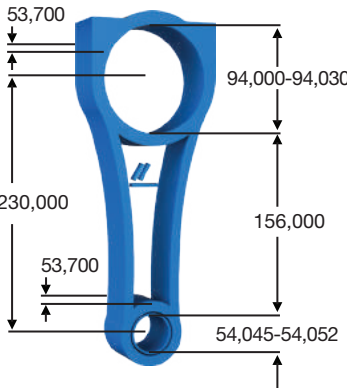



Engine Type	Models	Picture	Sizes (mm)	Products	BMY Reference
<b>4</b> Isuzu 4JA1 2.5 cc R4	TFR54, Cameo, Panther, Wizard,  Opel Frontera		<p>32,950 55,985-56,010 152,000 108,500 32,950 31,020-31,035</p> <p>1105 gr   Torque : 100 Nm</p>	Connecting Rod STD <b>BMY0405</b> 1 pc.24x10x4cm  Connecting Rod SEMI <b>BMY0405SEMI</b> 1 pc.24x10x4cm  Bushing Bimetal Locked-Straight <b>BMY0405B</b> 4 pcs.10x6x4cm  Bolt - 12.9 M11x1,25 L: 58 mm  Con. Rod OEM : 8943331190	
<b>5</b> Isuzu 4JA1-T/C 2.5 cc R4	D-Max Pick Up 4x2/4x4, Cameo, Panther, Wizard,  Opel Frontera		<p>32,950 55,985-56,010 152,000 108,500 32,950 31,020-31,035</p> <p>1065 gr   Torque : 100 Nm</p>	Connecting Rod STD <b>BMY0406</b> 1 pc.24x10x4cm  Connecting Rod SEMI <b>BMY0406SEMI</b> 1 pc.24x10x4cm  Bushing Bimetal Locked-Straight <b>BMY0405B</b> 4 pcs. 10x6x4cm  Bolt - 12.9 M11x1,25 L: 58 mm  Con. Rod OEM : 8973577163	
<b>6</b> Isuzu 4JB1-T 2.8 cc R4	NKR55  Karsan J9 Premier	<p>32,950 55,985-56,010 168,000 124,500 32,950 31,020-31,035</p> <p>1185 gr   Torque : 80 Nm</p>	Connecting Rod STD <b>BMY0407</b> 1 pc.24x10x4cm  Connecting Rod SEMI <b>BMY0407SEMI</b> 1 pc.24x10x4cm  Bushing Bimetal Locked-Straight <b>BMY0405B</b> 4 pcs. 10x6x4cm  Bolt - 10.9 M10x1,25 L:49 mm  Con. Rod OEM : 8943296920		



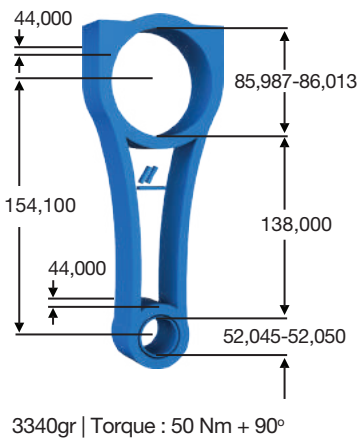

Engine Type	Models	Picture	Sizes (mm)	Products	BMV Reference
<b>7</b> Isuzu 4JK1 Euro4 - 5 2.5 cc  Isuzu 4JJ1 Euro4 - 5 3.0 cc  R4	D-Max  NPR, NLR, NNR			Connecting Rod STD	<b>BMV0408</b> 1 pc.24x10x4cm
				Connecting Rod SEMI	<b>BMV0408SEMI</b> 1 pc.24x10x4cm
				Bushing Bimetal Locked-Straight	<b>BMV0408B</b> 4 pcs. 10x6x4cm
				Bolt - 10.9 M10x1,25 L:49 mm	
				Cross References Con. Rod OEM : 8973577163	
					
					



Engine Type	Models	Picture	Sizes (mm)	Products	BMY Reference
<b>1</b> Iveco - Fiat F1AE 2.3 cc R4	Iveco Daily			Connecting Rod STD	<b>BMY1405</b> 1 pc.30x12x6cm
	Fiat Ducato			Connecting Rod SEMI	<b>BMY1405SEMI</b> 1 pc.30x12x6cm
	UAZ Patriot			Bushing Bimetal Locked-Straight	<b>BMY1405B</b> 4 pcs. 10x6x4cm
	Karsan Jest/J10			Bolt M10x1,25 L: 49 mm	<b>BMY1405CB</b> 8 pcs. 10x6x4cm
				Con. Rod OEM: 504 341 501 504 057 276	
					
			1140 gr   Torque : 80 Nm 2nd Torque Option : 40 Nm + 60 °		
<b>2</b> Iveco - Fiat 3.0 JTD F1CE Mitsubishi 4P10-7AT/T2/T4/T6 3.0 cc R4	Iveco Daily, Fiat Ducato Massif			Connecting Rod STD	<b>BMY1406</b> 1 pc.30x12x6cm
	Citroen Jumper			Connecting Rod SEMI	<b>BMY1406SEMI</b> 1 pc.30x12x6cm
	Mitsubishi Fuso Canter 8B/9BL			Bushing Bimetal Locked-Straight	<b>BMY1406B</b> 4 pcs. 10x6x4cm
				Bolt - 10.9 M10x1,25 L:49 mm	
				Con. Rod OEM: 504 341 496	
					
			1340 gr   Torque : 80 Nm		
<b>3</b> Iveco - Fiat F1AF-F1AG 2.3 cc R4 Euro 6	Iveco Daily			Connecting Rod STD	<b>BMY1407</b> 1 pc.24x10x4cm
	Fiat Ducato			Connecting Rod SEMI	<b>BMY1407SEMI</b> 1 pc.24x10x4cm
				Bushing Bimetal Locked-Straight	<b>BMY1407B</b> 4 pcs. 10x6x4cm
				Bolt - 10.9 M9x1 L:46 mm	<b>BMY0805CB</b> 8 pcs. 10x6x4cm
				Con. Rod OEM: 5801841535, 5801842210 5802116073	
					
			985 gr   Torque : 60 Nm		

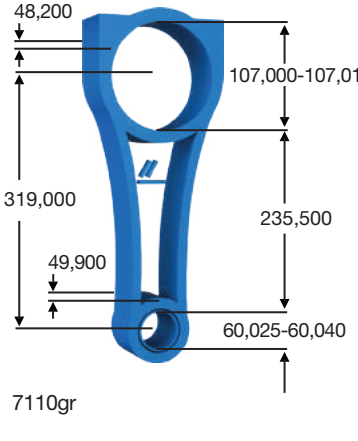





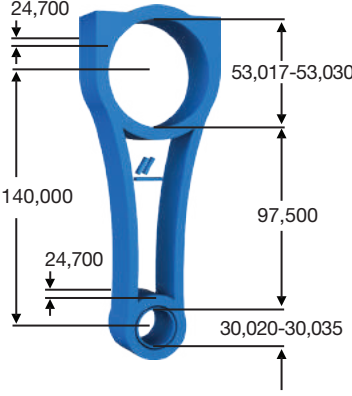

Engine Type	Models	Picture	Sizes (mm)	Products	BMY Reference
<p><b>4</b></p> <p>Iveco - Fiat Sofim 8140/S8W/S9W</p> <p>2.8 cc</p> <p>R4</p>	<p>Iveco Daily</p> <p>Fiat Ducato</p> <p>Renault Master, Mascott</p> <p>Opel Movano</p> <p>Citroën Jumper</p> <p>Peugeot Boxer</p>		 <p>1290 gr   Torque : 80 Nm</p>	<p>Connecting Rod STD <b>BMY0803</b> 1 pc.24x10x4cm</p> <p>Connecting Rod SEMI <b>BMY0803SEMI</b> 1 pc.24x10x4cm</p> <p>Bushing Bimetal Locked-Straight <b>BMY0803B</b> 4 pcs. 10x6x4cm</p> <p>Bolt - 10.9 M10x1,25 L:58 mm</p> <p>Con. Rod OEM: 500 352 497</p>	
   	  				
<p><b>5</b></p> <p>Iveco F4AF, F6AFE, NEF6</p> <p>Euro 6</p> <p>6.8(6728)cc</p> <p>R6</p>	<p>Iveco EuroCargo IV/V, Chassi Bus, Tector I, Crossway, Cityclass</p> <p>Daewoo Prima, Novus</p> <p>Irisbus Crossway</p>		 <p>1780 gr   Torque : 60 Nm + 60°</p>	<p>Connecting Rod STD <b>BMY1451</b> 1 pcs.48x15x6cm</p> <p>Connecting Rod SEMI <b>BMY1451SEMI</b> 1 pcs.48x15x6cm</p> <p>Bushing Bimetal Locked-Straight <b>BMY1451B</b> 4 pcs.10x6x4cm</p> <p>Bolt - 10.9 M10x1,25 L:51mm</p> <p>Con. Rod OEM : 5801441818, 5802086556, 5801441820, 5801839911</p>	
   	  				
<p><b>6</b></p> <p>Iveco/Case/ Fiat F3BE</p> <p>Euro III</p> <p>13(12882) cc</p> <p>R6</p>	<p>Cursor 13, HD9, Stralis I, Trakker I, Eurostar, EuroTrakker</p>		 <p>4820 gr Torque : 120 Nm + 60° + 30°</p>	<p>Connecting Rod STD <b>BMY1452</b> 1 pcs.48x15x6cm</p> <p>Connecting Rod SEMI <b>BMY1452SEMI</b> 1 pcs.48x15x6cm</p> <p>Bushing Bimetal Locked-Straight <b>BMY1452B</b> 4 pcs.10x6x4cm</p> <p>Con. Rod OEM: 504028545</p>	
   	  				

Engine Type	Models	Picture	Sizes (mm)	Products	BYM Reference
<b>7</b> Iveco/Case/ Steyr F2CE, F2CFA, F2CFE, F2CFG, F2CGE, F2CFP, NEF8  Euro 6  8.8 (8709) cc  R6	Iveco Cursor IX, Stralis II, S Way, Trakker II, T-Way, X-Way, Urbanway Daewoo Novus,  Fiat Series 300			Connecting Rod STD <b>BYM1453</b> 1 pcs.48x15x6cm  Connecting Rod SEMI <b>BYM1453SEMI</b> 1 pcs.48x15x6cm  Bushing Bimetal Locked-Straight <b>BYM1453B</b> 4 pcs.10x6x4cm	Con. Rod OEM : 504254665, 5801654901, 5801757115    

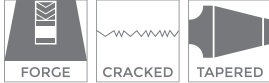

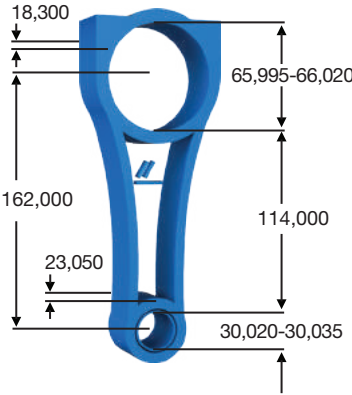

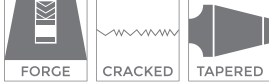

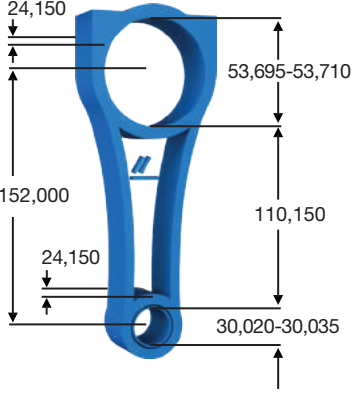
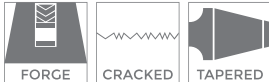

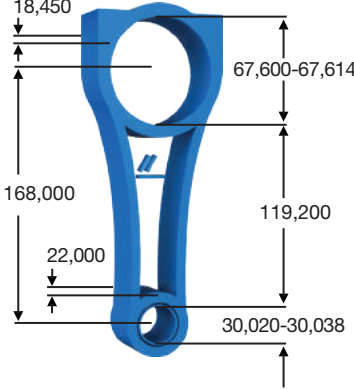

Engine Type	Models	Picture	Sizes (mm)	Products	BYM Reference
<b>1</b> Jenbacher J320				Connecting Rod STD <b>BYM2151</b> 1 pc.  Bolt - 10.09 M18x1,5 L: 96mm  Con. Rod OEM : 424942	  

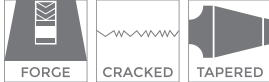

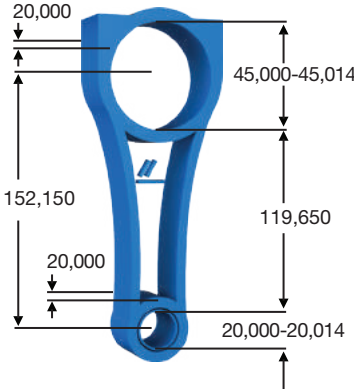

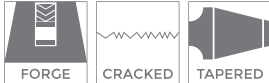

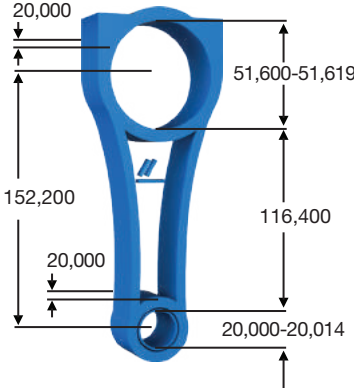

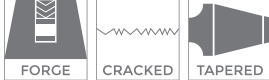

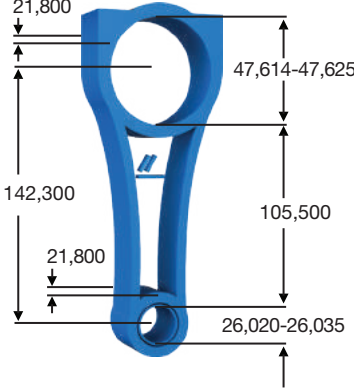

Engine Type	Models	Picture	Sizes (mm)	Products	BMY Reference	
<b>1</b> Land Rover 276DT, TDV6, TVM Peugeot UHZ(DT17) V6 - 2.7 cc Land Rover 368DT V8 - 3.6 cc 2.7 - 3.6 cc	Discovery III - IV Range Rover - Sport Jaguar S-Type, XF, XJ Peugeot 407, 607/Coupe/SW		<p>683 gr   Torque : 45 Nm 2nd Torque Option : 20 Nm + 80 °</p>	Connecting Rod STD Connecting Rod SEMI Bushing Bimetal Locked-Straight Bolt - 10.9 M8x1 L: 47mm	<b>BMY0201</b> 2 pcs.30x12x6cm <b>BMY0201SEMI</b> 2 pcs.30x12x6cm <b>BMY0201B</b> 3 pcs. 10x6x4cm <b>BMY0201CB</b> 12 pcs.10x6x4cm Con. Rod OEM : DE116250 DA6625, LR010297	
		<b>2</b> Land Rover AJD V6-DT20 306DT, 30DDTX Euro 5 3.0 cc V6 Discovery IV Range Rover IV - Sport Jaguar XF, XF Sportbrake, XJ Citroen C5 III, C6 Peugeot 407 Coupe		<p>712 gr   Torque : 45 Nm</p>	Connecting Rod STD Connecting Rod SEMI Bushing Bimetal Locked-Straight Bolt - 10.9 M8x1 L: 47mm	<b>BMY0202</b> 2 pcs.30x12x6cm <b>BMY0202SEMI</b> 2 pcs.30x12x6cm <b>BMY0202B</b> 3 pcs.10x6x4cm <b>BMY0201CB</b> 12 pcs.10x6x4cm Con. Rod OEM : DA6626, LR051508, LR038168
		<b>3</b> Land Rover 204DTA 241ps Jaguar JLR 240ps 2.0 (1999) cc R4 Euro 6 Range Rover Evoque Range Rover Evoque Convertible Range Rover Velar Discovery V Jaguar XE, XF, F-Pace		<p>817 gr   Torque : 50 Nm</p>	Connecting Rod STD Connecting Rod SEMI Bushing Bimetal Locked-Straight Bolt - 10.9 M8x1 L: 47mm	<b>BMY0203</b> 1 pc.30x12x6cm <b>BMY0203SEMI</b> 1 pc.30x12x6cm <b>BMY0203B</b> 4 pcs. 10x6x4cm <b>BMY0201CB</b> 8 pcs. 10x6x4cm Con. Rod OEM: LR124261

Engine Type	Models	Picture	Sizes (mm)	Products	BMY Reference	
<p><b>4</b></p> <p>Land Rover 204 DTD</p> <p>180ps</p> <p>R4 - 2.0cc</p>	<p>Ranger Rover Evoque</p> <p>Ranger Rover Velar</p> <p>Discovery Sport</p> <p>Discovery V</p>		 <p>24,700</p> <p>53,017-53,030</p> <p>140,000</p> <p>24,700</p> <p>97,500</p> <p>30,020-30,035</p> <p>755 gr   Torque : 45 Nm 2nd Torque Option : 20Nm+80°</p>	<p>Connecting Rod STD <b>BMY0204</b> 1 pc.24x10x4cm</p> <p>Connecting Rod SEMI <b>BMY0204SEMI</b> 1 pc.24x10x4cm</p> <p>Bushing Bimetal Locked-Straight <b>BMY0203B</b> 4 pcs. 10x6x4cm</p> <p>Bolt - 10.9 M8x1 L: 47mm <b>BMY0201CB</b> 12 pcs. 10x6x4cm</p> <p>Con. Rod OEM: LR082540, AJ813171</p>		
<p><b>5</b></p> <p>Land Rover 448DT Euro 5</p> <p>4.4 cc</p> <p>V8</p>	<p>Ranger Rover III / IV / Sport II</p>		 <p>18,300</p> <p>65,995-66,020</p> <p>162,000</p> <p>23,050</p> <p>114,000</p> <p>30,020-30,035</p> <p>705 gr   Torque : 45 Nm 2nd Torque Option : 20Nm+80°</p>	<p>Connecting Rod STD <b>BMY0205</b> 1 pc.30x12x4cm</p> <p>Connecting Rod SEMI <b>BMY0205SEMI</b> 1 pc.30x12x4cm</p> <p>Bushing Bimetal Locked-Straight <b>BMY0202B</b> 4 pcs. 10x6x4cm</p> <p>Bolt - 10.9 M8x1 L: 47mm <b>BMY0201CB</b> 8 pcs. 10x6x4cm</p> <p>Con. Rod OEM: LR035361 (Engine OEM)</p>		
<p><b>6</b></p> <p>Land Rover/Jaguar 224DT</p> <p>Peugeot/Citroen/ Opel/Fiat/ Lancia/ Tata/Vauxhall/ Ford DW12C/ FUD/RU/RUC/ RUD/RUE/ MTED4/BTED4/ UTED/ME5/ TED4/DD</p> <p>2.2 cc</p> <p>R4</p>	<p>Phedra</p> <p>Ulysse</p> <p>406, 508, 607, 807, Boxer C5, C6, C8, Xsara, Jumper Range Rover Evoque, Freelander II, Discovery Sport XF, XFI, XF Sportbrake</p>		 <p>24,150</p> <p>53,695-53,710</p> <p>152,000</p> <p>24,150</p> <p>110,150</p> <p>30,020-30,035</p> <p>790 gr   Torque : 60 Nm</p>	<p>Connecting Rod STD <b>BMY0812</b> 1 pc.24x10x4cm</p> <p>Connecting Rod SEMI <b>BMY0812SEMI</b> 1 pc.24x10x4cm</p> <p>Bushing Bimetal Locked-Straight <b>BMY0811B</b> 4 pcs. 10x6x4cm</p> <p>Bolt - 10.9 M9x1 L:46 mm</p> <p>Con. Rod OEM : 0603 95, 0603 C3, 9688244280, 9688245380, 9833274780 (L.Rover: LR001227, LR019693, LR051836)</p>		

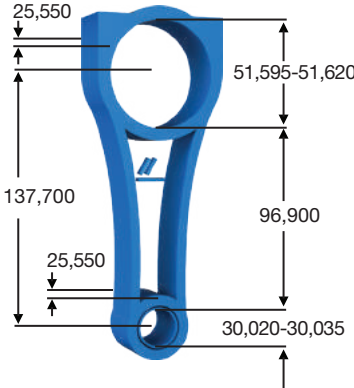

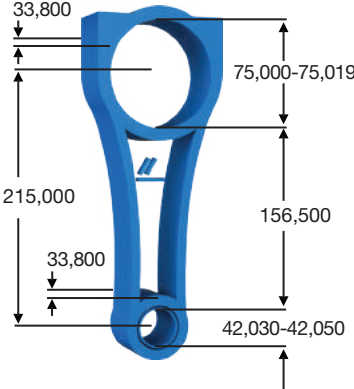

Engine Type	Models	Picture	Sizes (mm)	Products	BMY Reference
<b>1</b> Mercedes-Benz OM611, OM613 2.1 - 2.2 - 3.2 cc R4 - R6	Mercedes-Benz C-E-S-Class, Vito, Sprinter		<p>760 gr   Torque : 45 Nm 2nd Torque Option : 25 Nm + 90 °</p>	Connecting Rod STD	<b>BMY0713</b> 1 pc.24x10x4cm
				Connecting Rod SEMI	<b>BMY0713SEMI</b> 1 pc.24x10x4cm
				Bushing Bimetal Locked-Straight	<b>BMY0713B</b> 4 pcs. 10x6x4cm
				Bolt - 10.9 M8x1 L:47 mm	<b>BMY0714CB</b> 8 pcs. 10x6x4cm
				Con. Rod OEM : 611 030 0520	
<b>2</b> Mercedes-Benz OM612, OM646 2.2 - 2.7 cc R4 - R5	Mercedes-Benz C-E-CLK-ML-G Class, Sprinter, Vito, Viano		<p>750 gr   Torque : 45 Nm 2nd Torque Option : 25 Nm + 90 °</p>	Connecting Rod STD	<b>BMY0714</b> 1 pc.24x10x4cm
				Connecting Rod SEMI	<b>BMY0714SEMI</b> 1 pc.24x10x4cm
				Bushing Bimetal Locked-Straight	<b>BMY0714B</b> 4 pcs. 10x6x4cm
				Bolt - 10.9 M8x1 L:47 mm	<b>BMY0714CB</b> 8 pcs. 10x6x4cm
				Con. Rod OEM : 646 030 0020	
<b>3</b> Mercedes-Benz OM651 Jeep OM651 Freightliner OM651 2.2 cc R4	Mercedes-Benz Vito, A-B-C-E GLK-CLS, MLS -SLK Class, Viano, Sprinter Jeep Compass 2.2. CRD Freightliner Sprinter		<p>760 gr   Torque : 45 Nm 2nd Torque Option : 25 Nm + 90 °</p>	Connecting Rod STD	<b>BMY0715</b> 1 pc.24x10x4cm
				Connecting Rod SEMI	<b>BMY0715SEMI</b> 1 pc.24x10x4cm
				Bushing Bimetal Locked-Straight	<b>BMY0714B</b> 4 pcs. 10x6x4cm
				Bolt - 10.9 M8x1 L:47 mm	<b>BMY0714CB</b> 8 pcs. 10x6x4cm
				Con. Rod OEM : 651 030 0020	

Engine Type	Models	Picture	Sizes (mm)	Products	BMY Reference
<p><b>4</b></p> <p>Mercedes-Benz OM642</p> <p>3.0cc - V6</p>	<p>Vito, Mixto, Sprinter, E300D, CLK, GLK, GLE, GLS, C300 320/350 CDI, Viano, CLK 320 CDI, CLS 320 CDI, CLS 350 BlueTEC, CLS 350 CDI, E280/300/320/350 BlueTEC CDI, G280/300/320/350 CDI/d GL 320/350 CDI, ML 280/300/320/350 BlueTEC CDI, R280/300/320/350 CDI, S320/350 BlueTEC/CDI, X350d</p>		 <p>870gr   Torque : 60 Nm</p>	<p>Connecting Rod STD <b>BMY0716</b> 1 pc.30x12x6cm</p> <p>Connecting Rod SEMI <b>BMY0716SEMI</b> 1 pc.30x12x6cm</p> <p>Bolt - 10.9 M8x1 L:47 mm</p>	<p>Con. Rod OEM : 642 030 4120, 642 030 5220</p>
					
<p><b>5</b></p> <p>Mercedes-Benz M270.910, M274.910 2014 -&gt;</p> <p>1.6cc</p> <p>R4</p>	<p>C180/CGI, E180, SLC 180, A160, A200, B160, B180, B200, CLA180, CLA200, GLA180, GLA200</p>		 <p>440gr   Torque : 60 Nm</p>	<p>Connecting Rod STD <b>BMY0717</b> 1 pc.26x10x4cm</p> <p>Connecting Rod SEMI <b>BMY0717SEMI</b> 1 pc.26x10x4cm</p> <p>Bolt - 10.9 M8x1 L: 38 mm</p>	<p>Con. Rod OEM : 270 030 00 20, 270 030 03 20, 270 030 04 20, 270 030 05 20, 270 030 08 20</p>
					
<p><b>6</b></p> <p>Mercedes-Benz M270.920, M274.920, M264.920</p> <p>2.0 cc</p> <p>R4</p>	<p>A, B, C, CLA, E, CLS, GLA, GLC, GLE, GLK, SLK, SLC, S Classes, Vito</p>		 <p>470 gr   Torque : 45 Nm 2nd Torque Option : 5Nm+15Nm+90°</p>	<p>Connecting Rod STD <b>BMY0718</b> 1 pc.24x10x4cm</p> <p>Connecting Rod SEMI <b>BMY0718SEMI</b> 1 pc.24x10x4cm</p> <p>Bushing Bimetal Locked-Straight <b>BMY0717B</b> 4 pcs. 10x6x4cm</p> <p>Bolt - 10.9 M7x1 L: 38 mm <b>BMY0806CB</b> 8 pcs. 10x6x4cm</p>	<p>Con. Rod OEM : 2740303400, 2700300120, 2740300020, 2740300400, 2740301800</p>
					



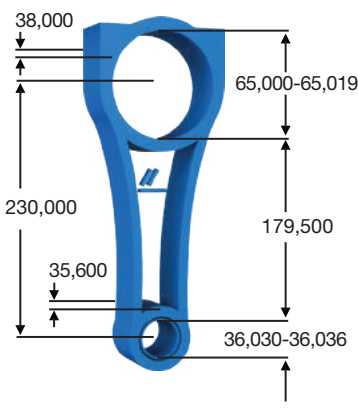





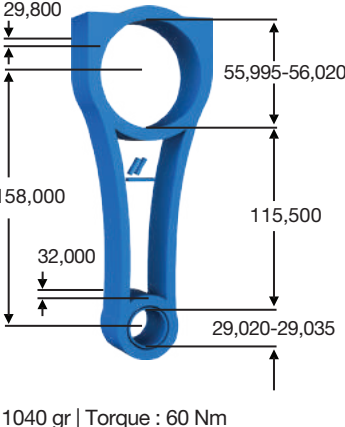

Engine Type	Models	Picture	Sizes (mm)	Products	BMY Reference
<b>7</b> Mercedes-Benz OM654.920 2.0(1950)cc R4 Mercedes-Benz OM656.929 3.0 cc R6	A, B, CLA, CLS, C, E, GLA, GLB, GLC, GLE, V Class, Sprinter, Vito S, CLS, E, G, GLE, GLS Class		715gr   Torque : 45Nm 2nd Torque Option : 25Nm+90°	Connecting Rod STD <b>BMY0719</b> 1 pc.24x10x4cm	Connecting Rod SEMI <b>BMY0719SEMI</b> 1 pc.24x10x4cm
				Bushing Bimetal Locked-Straight <b>BMY0719B</b> 4 pcs. 10x6x4cm	Bolt - 10.9 M8 L: 40 mm <b>BMY0719CB</b> 8 pcs. 10x6x4cm
				Con. Rod OEM : 654 030 7000, 654 030 0100	
<b>8</b> Mercedes-Benz OM654.820 2.0 (1992) cc R4	A, B, CLA, CLS, C, E, GLA, GLB, GLC, GLE, V Class, Sprinter, Vito		710 gr   Torque : 45 Nm 2nd Torque Option : 25Nm+90°	Connecting Rod STD <b>BMY0720</b> 1 pc.24x10x4cm	Connecting Rod SEMI <b>BMY0720SEMI</b> 1 pc.24x10x4cm
				Bushing Bimetal Locked-Straight <b>BMY0720B</b> 4 pcs. 10x6x4cm	Bolt - 10.9 M8 L: 40 mm <b>BMY0719CB</b> 8 pcs. 10x6x4cm
				Con. Rod OEM : 654 030 15 00	
<b>9</b> Mercedes-Benz OM626 Renault R9M 1.6 cc R4	Mercedes-Benz A, B, C, CLA-Class, Citan		655 gr   Torque : 60 Nm 2nd Torque Option : 20 Nm + 45 °	Connecting Rod STD <b>BMY0919</b> 1 pc.24x10x4cm	Connecting Rod SEMI <b>BMY0919SEMI</b> 1 pc.24x10x4cm
				Bushing Bimetal Locked-Straight <b>BMY0919B</b> 4 pcs. 10x6x4cm	Bolt - 10.9 M9x1 L:42 mm <b>BMY0901CB</b> 8 pcs. 10x6x4cm
				Con. Rod OEM : 626 030 0400, 95518876 Without Oil Hole	

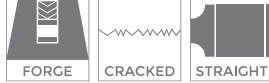

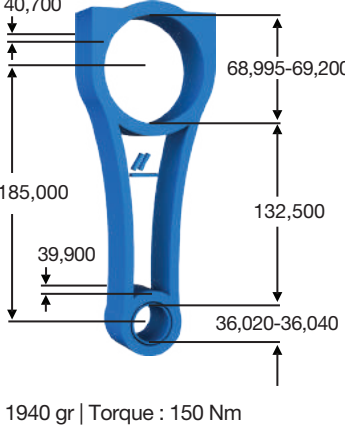



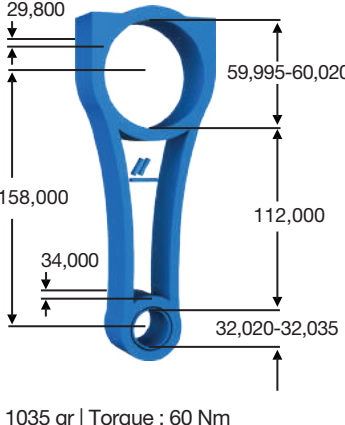

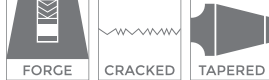
Engine Type	Models	Picture	Sizes (mm)	Products	BMY Reference
<b>10</b> Mercedes-Benz OM607, OM608  Renault K9K 846, K9K 608, 872  1.5 cc - R4  Euro 5/6  Used in forged-steel piston engines. Es wird in geschmiedeten Stahlkolbenmotoren. Dövme çelik pistonlu motorlarda kullanılır.	Mercedes-Benz A, B, CLA, GLA Class, Citan  Infiniti Q30  Renault Megane IV, Kadjar, Scenic IV, Clio Captur  Nissan Note, Micra  Dacia Lodgy		 <p>560 gr   Torque : 60 Nm 2nd Torque Option : 20 Nm + 45 °</p>	Connecting Rod STD <b>BMY0902</b> 1 pc.24x10x4cm  Connecting Rod SEMI <b>BMY0902SEMI</b> 1 pc.24x10x4cm  Bushing Bimetal Locked-Straight <b>BMY0901B</b> 4 pcs. 10x6x4cm  Bolt - 10.9 M9x1 L:42 mm <b>BMY0901CB</b> 8 pcs. 10x6x4cm  Con. Rod OEM : 607 030 0420	 
<b>11</b> Renault/Nissan R9M Mercedes-Benz OM626 Fiat/Opel/Vauxhall R9M  1.6 cc  R4  Long Type Langer Typ Uzun Tip	Talisman, Fluence, Megane, Trafic Scenic, Koleos, Espace  Qashqai, Juke X-Trail, NV300,  C Class  Vivaro  Talento		 <p>675 gr   Torque : 60Nm 2nd Torque Option : 20Nm+45°</p>	Connecting Rod STD <b>BMY0904</b> 1 pc.24x10x4cm  Connecting Rod SEMI <b>BMY0904SEMI</b> 1 pc.24x10x4cm  Bushing Bimetal Locked-Straight <b>BMY0916B</b> 4 pcs. 10x6x4cm  Bolt - 10.9 M9x1 L:42 mm <b>BMY0901CB</b> 8 pcs. 10x6x4cm  Con. Rod OEM : 121001039R, 121004759R, 1210000Q1H, 626 030 0420	 
<b>12</b> Mercedes-Benz OM904, OM907, 4.3(4249)cc R4  Mercedes-Benz OM924 4.8(4801)cc  Mercedes-Benz OM906, OM909, 6.4 (6374) cc R6  Mercedes-Benz OM926 7.2 (7201) cc R6  	Mercedes-Benz Axor I/II, Atego I/II, Zetros, Unimog, Beaver, Econic, Touro (O 500), 7-T/9-T/10-T 11-T/12-T/13-T 14-T/15-T/16-T 17-T/24-T Ser., LK/LN2, OF, OH, LO, OMC, O 500, MB, Cito (O 520), HPN, Boxer, O530, Vario, Allegro, Alliado, Citaro I (O530)/II, Conecto (O345), Touro (O 500), Frieghtliner Fap Famos B-Series		 <p>1920 gr   Torque : 10Nm+45Nm+90°</p>	Connecting Rod STD <b>BMY0751</b> 1 pc.48x15x6cm  Connecting Rod SEMI <b>BMY0751SEMI</b> 1 pc.48x15x6cm  Bushing Bimetal Locked-Straight <b>BMY0751B</b> 4 pcs. 10x6x4cm  Bolt - 10.9 M12x1,25 L: 56 <b>BMY0751CB</b> 8 pcs. 10x6x4cm  Con. Rod OEM : 906 030 1820, 906 030 1020, 906 030 0320, 906 030 0620, 906 030 2120, 906 030 1720	 

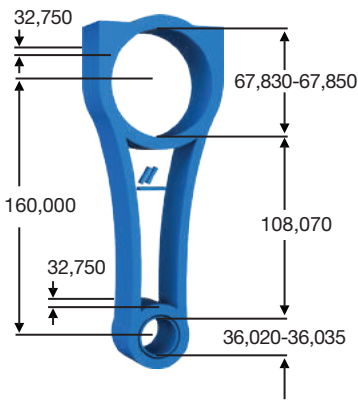
Engine Type	Models	Picture	Sizes (mm)	Products	BMY Reference
<b>13</b>					
Mercedes-Benz OM470	Mercedes-Benz Actros, Tourismo II,		<p>3770 gr   Torque: 150Nm + 90°</p>	Connecting Rod STD	<b>BMY0752</b> 1 pc.48x15x6cm
MTU 6R 1100 C30/C40/C50	Arcos, Antos, Citaro I/II, Capacity			Connecting Rod SEMI	<b>BMY0752SEMI</b> 1 pc.48x15x6cm
Euro 6	Setra Series 400/500			Bushing Bimetal Locked-Straight	<b>BMY0752B</b> 4 pcs. 10x6x4cm
11.7(10677) cc	MTU 6R			Bolt - 10.9 M14x1,50 L:74	<b>BMY0752CB</b> 8 pcs. 10x6x4cm
R6	Deutz Series 11			Con. Rod OEM : 470 030 0620, 470 030 0120, 470 030 0220, 470 030 0520	
<b>14</b>					
Mercedes-Benz OM471	Mercedes-Benz Actros, Arcos, Antos		<p>4400 gr Torque : 180 Nm+90°</p>	Connecting Rod STD	<b>BMY0753</b> 1 pc.48x15x6cm
Detroit Diesel DD13	Freightliner M2, 114, Cascadia, Century, Columbia, 122			Connecting Rod SEMI	<b>BMY0753SEMI</b> 1 pc.48x15x6cm
Fuso 6R10	Mitsubishi Fuso Super Great			Bushing Bimetal Locked-Straight	<b>BMY0753B</b> 4 pcs. 10x6x4cm
MTU 6R 1300	Setra Series 400/500			Bolt - 10.9 M15x1,5 L:78,5	<b>BMY0753CB</b> 8 pcs. 10x6x4cm
Euro 6	MTU Serie 1300			Con. Rod OEM : 471 030 0820	
12.9 (12809) cc	Deutz Series 11				
R6	Western Star 4800, 5000, 5800, 6900				











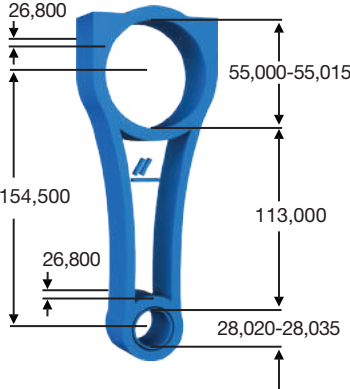







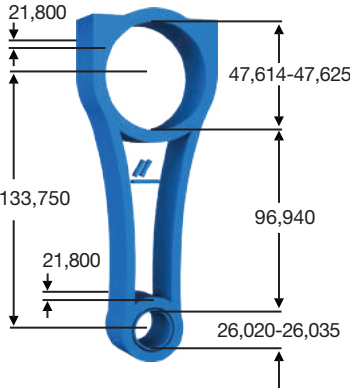





Engine Type	Models	Picture	Sizes (mm)	Products	BM Y Reference
<b>15</b>					
Mercedes-Benz, Fap-Famous, CBT Clark MHC, Hanomog, IHC- Case (CNH), Komatsu, New Holland, Toyota OM304, OM306, OM314, OM340, OM341, OM343, OM344, OM352, OM353, OM354, OM356, OM357, OM362, OM364, OM366, OM370, OM372, OM374, OM376, OM377, OM380, OM382, OM384, OM386, OM390, OM394, OM396, M352	2517, 2521, 1105, 2080, 2105, 2600, 55C, 714SP, 1317, 1318, 1319, 1320, 1414, 1416, 1417, 1418, 1419, 1420, 1421, 1422, 1424, 1513, 1514, 1516, 1521, 1524, 1526, 1551, 1560, 1613, 2214, 2216, 2217, 2219, 2220, 2314, 2318, 2320, 2420, 2421		 <p>38,000 65,000-65,019 230,000 179,500 35,600 36,030-36,036 1950 gr   Torque: 40Nm + 90°</p>	Connecting Rod STD	<b>BM Y0754</b> 1 pc. 48x15x6cm
				Con. Rod OEM : 366 030 3520, 366 030 2520, 366 030 2120, 366 030 7120	
					

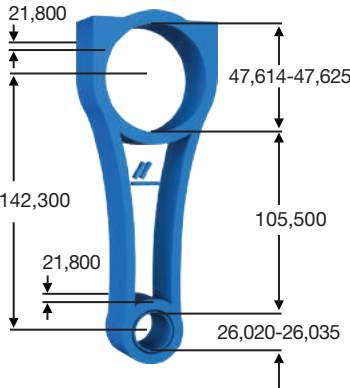









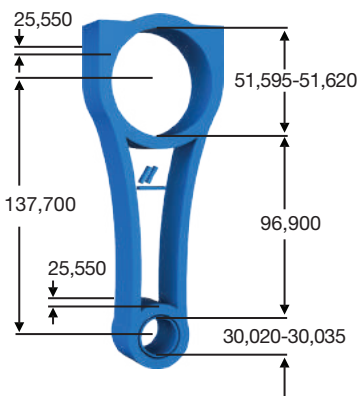

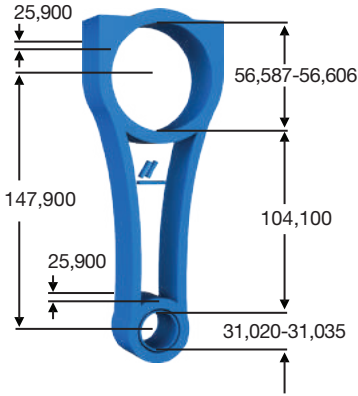

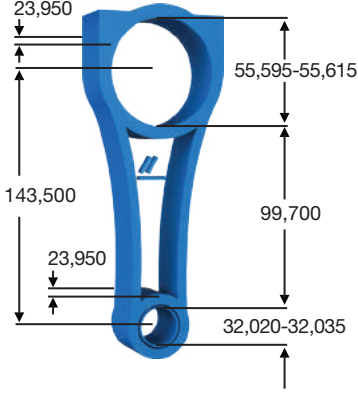





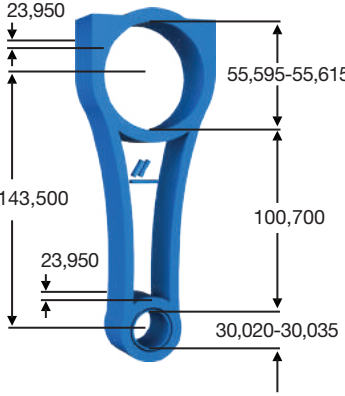





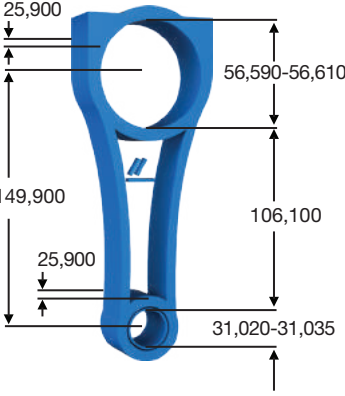





Engine Type	Models	Picture	Sizes (mm)	Products	BMY Reference
<b>1</b> Mitsubishi 4D55T, 4D56 Hyundai D4BF, D4BB, D4BH 2.5 cc R4	Mitsubishi L200/300 Hyundai Starex/H100		 <p>29,800 55,995-56,020 158,000 115,500 32,000 29,020-29,035 1040 gr   Torque : 60 Nm</p>	Connecting Rod STD <b>BMY1303</b> 1 pc.24x10x4cm	Connecting Rod SEMI <b>BMY1303SEMI</b> 1 pc.24x10x4cm
				Bushing Bimetal Locked-Straight <b>BMY1303B</b> 4 pcs. 10x6x4cm	Bolt - 10.9 M9x1 L:46 mm Con. Rod OEM : MD371001 2351042010
					
<b>2</b> Mitsubishi 4D34T 3.9 cc R4	Mitsubishi Canter FE659T		 <p>40,700 68,995-69,200 185,000 132,500 39,900 36,020-36,040 1940 gr   Torque : 150 Nm</p>	Connecting Rod STD <b>BMY1304</b> 1 pc.24x10x4cm	Connecting Rod SEMI <b>BMY1304SEMI</b> 1 pc.24x10x4cm
				Bushing Bimetal Locked-Straight <b>BMY1304B</b> 4 pcs. 10x6x4cm	Bolt - 12.9 M12,5x1,25 L:68 Con. Rod OEM : ME012266
					
<b>3</b> Mitsubishi 4D56 TDI, 4D56T, 4D56U 2.5 cc R4	Mitsubishi L200/300 Hyundai H100 (2015-...)		 <p>29,800 59,995-60,020 158,000 112,000 34,000 32,020-32,035 1035 gr   Torque : 60 Nm</p>	Connecting Rod STD <b>BMY1305</b> 1 pc.24x10x4cm	Connecting Rod SEMI <b>BMY1305SEMI</b> 1 pc.24x10x4cm
				Bushing Bimetal Locked-Straight <b>BMY1305B</b> 4 pcs. 10x6x4cm	Bolt - 10.9 M9x1 L:46 mm Con. Rod OEM : 1115 A345, 1115 A035, 1115A343
					

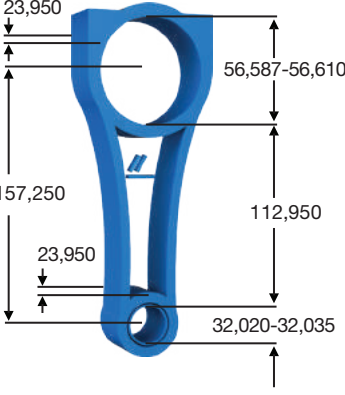









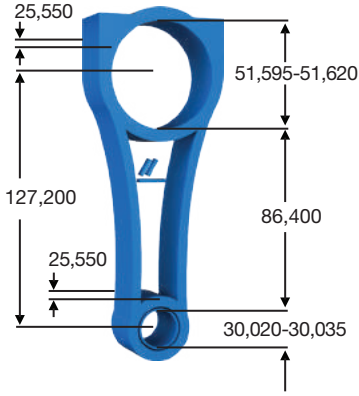





Engine Type	Models	Picture	Sizes (mm)	Products	BMV Reference
<b>4</b> Mitsubishi 4P10-7AT/T2/T4/T6 Fiat/Iveco 3.0 JTD F1CE 3.0 cc R4	Mitsubishi Fuso Canter 8B/9BL Fiat Ducato Iveco Daily, Massif Citroen Jumper		 1340 gr   Torque : 85 Nm	Connecting Rod STD Connecting Rod SEMI Bushing Bimetal Locked-Straight Bolt - 10.9 M10x1,25 L:49 mm Con. Rod OEM : 504 341 496	<b>BMV1406</b> 1 pc.30x12x6cm <b>BMV1406SEMI</b> 1 pc.30x12x6cm <b>BMV1406B</b> 4 pcs. 10x6x4cm
   		  			

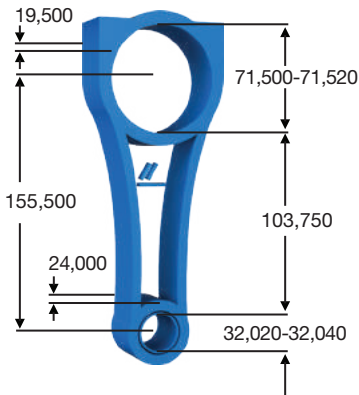











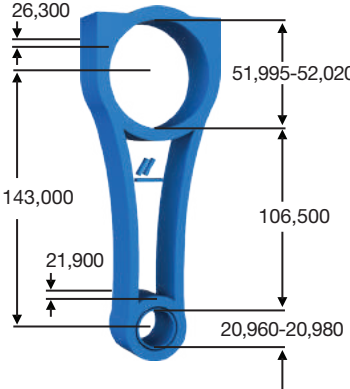



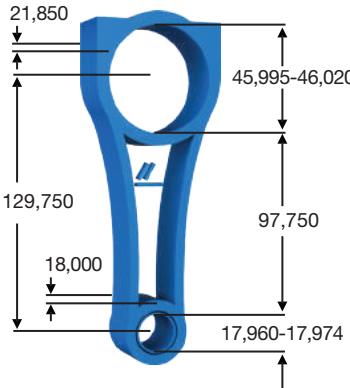

Engine Type	Models	Picture	Sizes (mm)	Products	BMY Reference
<b>1</b> Nissan YD22/ YD25  2.5 cc  R4	Nissan Primera, Almera X-Trail, Navara, Frontier, Pathfinder		 <p>26,800 55,000-55,015 154,500 26,800 113,000 28,020-28,035</p> <p>940 gr   Torque : 60 Nm</p>	Connecting Rod STD  Connecting Rod SEMI  Bushing Bimetal Locked-Straight  Bolt - 10.9 M9x1 L:46 mm	<b>BMY1201</b> 1 pc.24x10x4cm  <b>BMY1201SEMI</b> 1 pc.24x10x4cm  <b>BMY1201B</b> 4 pcs. 10x6x4cm  Con. Rod OEM : 12100-EB33A
  	  				
<b>2</b> Nissan - Renault K9K  1.5 cc  R4	Nissan Micra, Qashqai, Juke		 <p>21,800 47,614-47,625 133,750 21,800 96,940 26,020-26,035</p> <p>535 gr   Torque : 60 Nm                      2nd Torque Option :                      20 Nm + 45 °</p>	Connecting Rod STD  Connecting Rod SEMI  Bushing Bimetal Locked-Straight  Bolt - 10.9 M9x1 L:42 mm	<b>BMY0901</b> 1 pc.24x10x4cm  <b>BMY0901SEMI</b> 1 pc.24x10x4cm  <b>BMY0901B</b> 4 pcs. 10x6x4cm  <b>BMY0901CB</b> 8 pcs. 10x6x4cm  Con. Rod OEM : 770 147 5074
  	  				
<b>3</b> Renault K9K 846, K9K 608, 872 Mercedes-Benz OM607, OM608 1.5 cc - R4  Euro 5/6  Used in forged-steel piston engines.  Es wird in geschmiedeten Stahlkolbenmotoren.  Dövmе çelik pistonlu motorlarda kullanılır.	Nissan Note, Micra  Infiniti Q30 Mercedes-Benz A, B, CLA, GLA Class, Citan Renault Megane IV, Kadjar, Scenic IV, Clio Captur  Dacia Lodgy		 <p>21,800 47,614-47,625 142,300 21,800 105,500 26,020-26,035</p> <p>560 gr   Torque : 60 Nm                      2nd Torque Option :                      20 Nm + 45 °</p>	Connecting Rod STD  Connecting Rod SEMI  Bushing Bimetal Locked-Straight  Bolt - 10.9 M9x1 L:42 mm	<b>BMY0902</b> 1 pc.24x10x4cm  <b>BMY0902SEMI</b> 1 pc.24x10x4cm  <b>BMY0901B</b> 4 pcs. 10x6x4cm  <b>BMY0901CB</b> 8 pcs. 10x6x4cm  Con. Rod OEM : 121008820R 6070302100, 12100-00QAJ, 12100-00Q1J
   	  				

Engine Type	Models	Picture	Sizes (mm)	Products	BMY Reference	
<p><b>4</b></p> <p>Renault/Nissan R9M Mercedes-Benz OM626 Fiat/Opel/Vauxhall R9M</p> <p>1.6 cc</p> <p>R4</p> <p>Long Type Langer Typ Uzun Tip</p>	<p>Talisman, Fluence, Megane, Trafic Scenic, Koleos, Espace</p> <p>Qashqai, Juke X-Trail, NV300,</p> <p>C Class</p> <p>Vivaro</p> <p>Talento</p>		<p>675 gr   Torque : 60Nm 2nd Torque Option : 20Nm+45°</p>	<p>Connecting Rod STD <b>BMY0904</b> 1 pc.24x10x4cm</p> <p>Connecting Rod SEMI <b>BMY0904SEMI</b> 1 pc.24x10x4cm</p> <p>Bushing Bimetal Locked-Straight <b>BMY0916B</b> 4 pcs. 10x6x4cm</p> <p>Bolt - 10.9 M9x1 L:42 mm <b>BMY0901CB</b> 8 pcs. 10x6x4cm</p> <p>Con. Rod OEM : 121001039R, 121004759R, 1210000Q1H, 626 030 0420</p>		
<p><b>5</b></p> <p>Nissan - Renault G9U</p> <p>2.5 cc</p> <p>R4</p>	<p>Nissan Interstar</p>		<p>870 gr   Torque : 60 Nm 2nd Torque Option : 20 Nm + 45 °</p>	<p>Connecting Rod STD <b>BMY0913</b> 1 pc.24x10x4cm</p> <p>Connecting Rod SEMI <b>BMY0913SEMI</b> 1 pc.24x10x4cm</p> <p>Bushing Bimetal Locked-Straight <b>BMY0913B</b> 4 pcs. 10x6x4cm</p> <p>Bolt - 10.9 M9x1 L:42 mm <b>BMY0901CB</b> 8 pcs. 10x6x4cm</p> <p>Con. Rod OEM : 770 147 3615</p>		
<p><b>6</b></p> <p>Nissan - Renault M9R</p> <p>2.0 cc</p> <p>R4</p>	<p>Nissan Qashqai, X-Trail</p>		<p>730 gr   Torque : 60 Nm 2nd Torque Option : 20 Nm + 45 °</p>	<p>Connecting Rod STD <b>BMY0915</b> 1 pc.24x10x4cm</p> <p>Connecting Rod SEMI <b>BMY0915SEMI</b> 1 pc.24x10x4cm</p> <p>Bushing Bimetal Locked-Straight <b>BMY0915B</b> 4 pcs. 10x6x4cm</p> <p>Bolt - 10.9 M9x1 L:42 mm <b>BMY0901CB</b> 8 pcs. 10x6x4cm</p> <p>Con. Rod OEM : 770 147 7831</p>		

Engine Type	Models	Picture	Sizes (mm)	Products	BMY Reference
<p><b>7</b></p> <p>Nissan - Renault M9R</p> <p>2.0 cc</p> <p>R4</p>	Nissan Qashqai, X-Trail		 <p>760 gr   Torque : 60 Nm 2nd Torque Option : 20 Nm + 45 °</p>	<p>Connecting Rod STD <b>BMY0916</b> 1 pc.24x10x4cm</p> <p>Connecting Rod SEMI <b>BMY0916SEMI</b> 1 pc.24x10x4cm</p> <p>Bushing Bimetal Locked-Straight <b>BMY0916B</b> 4 pcs. 10x6x4cm</p> <p>Bolt - 10.9 M9x1 L:42 mm <b>BMY0901CB</b> 8 pcs. 10x6x4cm</p> <p>Con. Rod OEM : 7701476577, 12100-00Q0A</p>	    
<p><b>8</b></p> <p>Nissan - Renault G9T</p> <p>2.2 cc</p> <p>R4</p>	Nissan Interstar, Primastar		 <p>873 gr   Torque : 60 Nm 2nd Torque Option : 20 Nm + 45 °</p>	<p>Connecting Rod STD <b>BMY0917</b> 1 pc.24x10x4cm</p> <p>Connecting Rod SEMI <b>BMY0917SEMI</b> 1 pc.24x10x4cm</p> <p>Bushing Bimetal Locked-Straight <b>BMY0913B</b> 4 pcs. 10x6x4cm</p> <p>Bolt - 10.9 M9x1 L:42 mm <b>BMY0901CB</b> 8 pcs. 10x6x4cm</p> <p>Con. Rod OEM : 770 147 2847</p>	     
<p><b>9</b></p> <p>Nissan - Renault M9T</p> <p>2.3 cc</p> <p>R4</p>	Nissan NV400, Navara, Qashqai, X-Trail, Primastar Mercedes-Benz X-Class		 <p>805 gr   Torque : 60 Nm 2nd Torque Option : 20 Nm + 45 °</p>	<p>Connecting Rod STD <b>BMY0918</b> 1 pc.24x10x4cm</p> <p>Connecting Rod SEMI <b>BMY0918SEMI</b> 1 pc.24x10x4cm</p> <p>Bushing Bimetal Locked-Straight <b>BMY0915B</b> 4 pcs. 10x6x4cm</p> <p>Bolt - 10.9 M9x1 L:42 mm <b>BMY0901CB</b> 8 pcs. 10x6x4cm</p> <p>Con. Rod OEM : 121004942R</p>	      

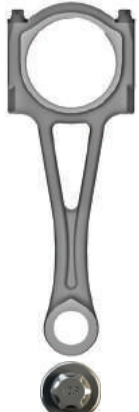
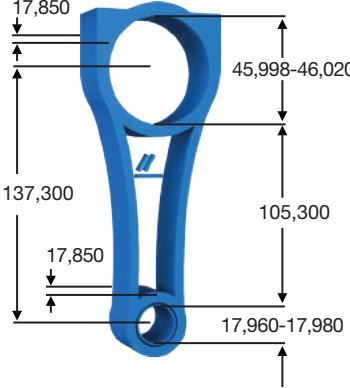



Engine Type	Models	Picture	Sizes (mm)	Products	BMY Reference
<b>10</b> Nissan-Renault R9M Mercedes-Benz OM626 1.6 cc R4	Nissan Juke, Almera, Cube, Micra, Note, NV200		 655 gr   Torque : 60 Nm 2nd Torque Option : 20 Nm + 45 °	Connecting Rod STD Connecting Rod SEMI Bushing Bimetal Locked-Straight Bolt - 10.9 M9x1 L:42 mm	<b>BMY0919</b> 1 pc.24x10x4cm <b>BMY0919SEMI</b> 1 pc.24x10x4cm <b>BMY0916B</b> 4 pcs. 10x6x4cm <b>BMY0901CB</b> 8 pcs. 10x6x4cm
  				  	
<b>11</b> Renault, Nissan, Infiniti V9X 3.0 cc V6	Renault Laguna III, Latitude Nissan Navara, Pathfinder Infiniti QX70D, FX30d, EX30d, M30d		 904gr   Torque : 60 Nm	Connecting Rod STD Connecting Rod SEMI Bushing Bimetal Locked-Straight Bolt - 10.9 M9x1 L:50 mm	<b>BMY0923</b> 1 pc.30x12x4cm <b>BMY0923SEMI</b> 1 pc.30x12x4cm <b>BMY0915B</b> 4 pcs. 10x6x4cm <b>BMY0901CB</b> 8 pcs. 10x6x4cm
   				  	

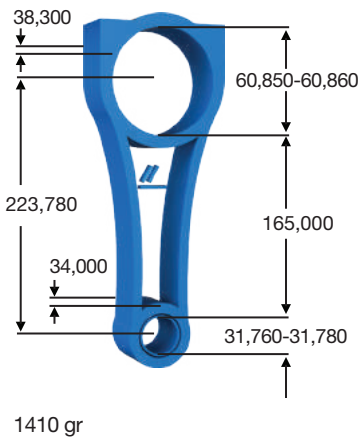

Engine Type	Models	Picture	Sizes (mm)	Products	BMY Reference
<b>1</b> Opel OHC C20LET/NE (8V,16V)  1.8 - 2.0 cc  R4	Opel Vectra, Astra, Omega  Saab 9-3  Lotus Europa S  Cadillac BLS		 <p>640 gr   Torque : 60 Nm</p>	Connecting Rod STD  Bolt - 10.9 M9x1 L:42 mm	<b>BMY1501</b> 1 pc.24x10x4cm
 	  				
<b>2</b> Opel OHC X16/ Z16 (8V,16V)  1.6 cc  R4	Opel Corsa, Astra, Vectra  Chavrolet Aveo		 <p>423 gr   Torque : 50 Nm</p>	Connecting Rod STD  Bolt - 10.9 M8x1 L:41 mm	<b>BMY1502</b> 1 pc.24x10x4cm
 	  				
<b>3</b> Opel Z12XEP, X12XEP A14XEP, Z14XEP, X14XEP Twinport  1.2 - 1.4 cc  R4	Opel/Vauxhall Corsa/Holden Tigra, Astra, Meriva, Astra J Zafira Tourer, Combo C, Adam, Mokka  Chevrolet Cruze, Volt  Buick Encore		 <p>355 gr   Torque : 45 Nm</p>	Connecting Rod STD  Bolt - 10.9 M7x1 L:38 mm	<b>BMY1503</b> 1 pc.24x10x4cm
 	 				

Engine Type	Models	Picture	Sizes (mm)	Products	BMY Reference
<b>4</b> Opel/Vauxhall A20DTH, A20DTJ Y20DTJ, Z20DTJ  Fiat D20AA Euro5  2.0 cc  R4	Opel Insignia, Astra J  Fiat Freemont, Doblo, Bravo Lancia/Chrysler Delta  Alfa Romeo Brera, Spider, 159, Giulietta		<p>740 gr   Torque : 70 Nm 2nd Torque Option : 25 Nm + 60 °</p>	Connecting Rod STD	<b>BMY1504</b> 1 pc.24x10x4cm
				Connecting Rod SEMI	<b>BMY1504SEMI</b> 1 pc.24x10x4cm
				Bushing Bimetal Locked-Straight	<b>BMY1504B</b> 4 pcs. 10x6x4cm
				Bolt - 10.9 M9x1 L:42 mm	<b>BMY0805CB</b> 8 pcs. 10x6x4cm
				Con. Rod OEM : 555 684 66, 555 978 94 <b>Without Bearing Lug            (for with Lug BMY1404)</b>	
<b>5</b> Opel - Vauxhall GM B16DTC, DTE, DTH, B16DTJ, DTL, DTN, DTR, DTU Euro 5, Euro 6  1.6 cc  R4	Astra J/K, Crossland X, Mervia B, Mokka X, Insignia A/B, Zafira C  Buick Regal		<p>600 gr   Torque : 60 Nm 2nd Torque Option : 25 Nm + 60 °</p>	Connecting Rod STD	<b>BMY1506</b> 1 pc.24x10x4cm
				Connecting Rod SEMI	<b>BMY1506SEMI</b> 1 pc.24x10x4cm
				Bushing Bimetal Locked-Straight	<b>BMY1506B</b> 4 pcs. 10x6x4cm
				Bolt - 10.9 M9x1 L: 46 mm	
				Con. Rod OEM : 55596544, 55501529	
<b>6</b> Opel - Vauxhall GM A16 LET, A16 XER Euro 5, Euro 6  1.6 cc  R4	Opel Vauxhall, Astra H, J, Insignia A, Mokka  Chevrolet Cruze, Aveo, Sonic, Trax  Buick Excelle		<p>420 gr   Torque : 45 Nm 2nd Torque Option : 10 Nm + 60 ° + 15 °</p>	Connecting Rod STD	<b>BMY1507</b> 1 pc.24x10x4cm
				Connecting Rod SEMI	<b>BMY1507SEMI</b> 1 pc.24x10x4cm
				Bushing Bimetal Locked-Straight	<b>BMY1507B</b> 4 pcs. 10x6x4cm
				Bolt - 10.9 M8x1 L : 38 mm	
				Con. Rod OEM : 622 111, 555 684 67	

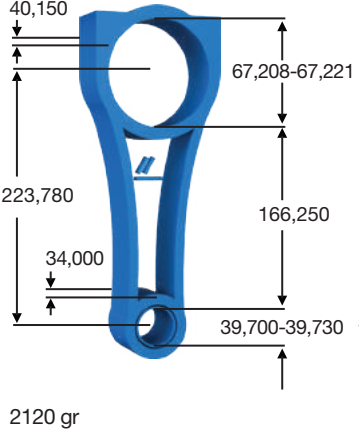







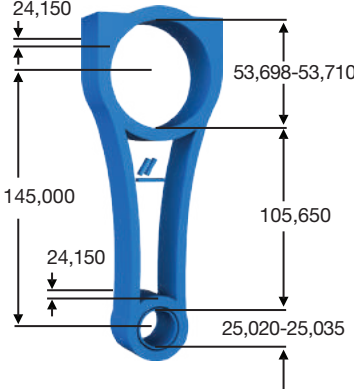

Engine Type	Models	Picture	Sizes (mm)	Products	BMY Reference
<p><b>7</b></p> <p>Opel-Vauxhall Chevrolet - GM A13DTC Euro 5, A13DTE, A13DTR Euro 5, A13FD Euro 5, B13DTC Euro 5, B13DTE, B13DTR, D13A Euro 4, Y13DT Euro 3/4, Z13DT Euro 4, Z13DTE Euro 4, Z13DTH Euro 4, Z13DTI Euro 4, Z13DTJ Euro 4, Z13DTR Euro 4, CDTI</p> <p>1.3 cc</p> <p>R4</p>	<p>Fiat Albea, Doblò, Fiorino, Grande Punto, Linea, 500, Palio, Panda, Punto Alfa Romeo, MiTo</p> <p>Lancia Musa, Ypsilon Suzuki Swift, SX4, Splach</p>		<p>23,700 45,725-45,750 131,350 23,700 96,975 23,020-23,040</p> <p>450 gr   Torque : 45 Nm 2nd Torque Option : 20Nm + 40 °</p>	<p>Connecting Rod STD</p> <p>Connecting Rod SEMI</p> <p>Bushing Bimetal Locked-Straight</p> <p>Bolt - 10.9 M8x1 L:38 mm</p> <p>Con. Rod OEM : 735 012 29, 552 086 24</p>	<p><b>BMY1401</b> 1 pc.24x10x4cm</p> <p><b>BMY1401SEMI</b> 1 pc.24x10x4cm</p> <p><b>BMY1401B</b> 4 pcs. 10x6x4cm</p> <p><b>BMY1401CB</b> 8 pcs. 10x6x4cm</p>
<p><b>8</b></p> <p>Opel Z19DT/H</p> <p>1.9 cc</p> <p>R4</p>	<p>Alfa Romeo 146,147,159,GT Cadillac BLS Fiat Doblo, Bravo, Punto Fiat Croma, Marea, Stilo Lancia Delta, Lybra, Musa Opel Signum, Vectra C Opel Zafira B Saab 9-3, 9-5, Suzuki SX4</p>		<p>21,950 53,900-53,920 145,000 21,950 105,040 26,020-26,030</p> <p>760 gr   Torque : 60 Nm</p>	<p>Connecting Rod STD</p> <p>Connecting Rod SEMI</p> <p>Bushing Bimetal Locked-Straight</p> <p>Bolt - 10.9 M9x1 L:46 mm</p> <p>Con. Rod OEM : 467 689 51</p>	<p><b>BMY1402</b> 1 pc.24x10x4cm</p> <p><b>BMY1402SEMI</b> 1 pc.24x10x4cm</p> <p><b>BMY1402B</b> 4 pcs. 10x6x4cm</p>
<p><b>9</b></p> <p>Opel-Chevrolet Z20DMH, Z20S, Z20DM</p> <p>2.0 cc</p> <p>R4</p>	<p>Chevrolet Captiva, Cruze, Lacetti, Epica</p> <p>Opel Antara 4x2, 4x4 150ps</p>		<p>27,850 52,995-53,019 145,800 27,850 105,300 28,020-28,035</p> <p>885 gr   Torque : 50 Nm</p>	<p>Connecting Rod STD</p> <p>Connecting Rod SEMI</p> <p>Bushing Bimetal Locked-Straight</p> <p>Bolt - 10.9 M8x1 L:47 mm</p> <p>Con. Rod OEM : 23510 27000, 23510 27300, 23510 27010, 23510 27400, 23510 27410, 96440175, 4807976</p>	<p><b>BMY0602</b> 1 pc.24x10x4cm</p> <p><b>BMY0602SEMI</b> 1 pc.24x10x4cm</p> <p><b>BMY0602B</b> 4 pcs. 10x6x4cm</p>

Engine Type	Models	Picture	Sizes (mm)	Products	BMY Reference
<b>1</b> Perkins/ Massey Ferguson D152, D203				Connecting Rod STD	<b>BMY2001</b> 1 pc.48x15x6cm
					
<b>2</b> Perkins, Massey Ferguson, Atlas Copco 1004-40, 1004-42, 1006-60  Caterpillar 3054C/E, 3056E				Connecting Rod STD	<b>BMY2002</b> 1 pc.48x15x6cm
					

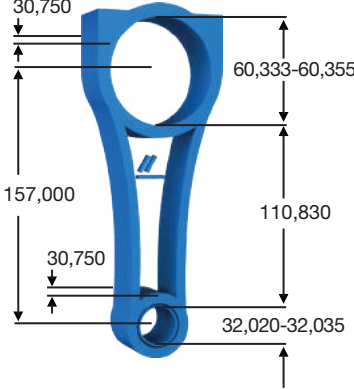

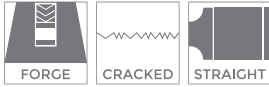

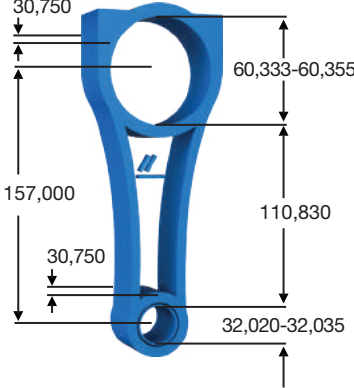

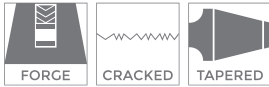



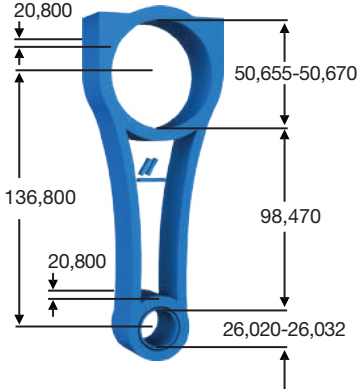



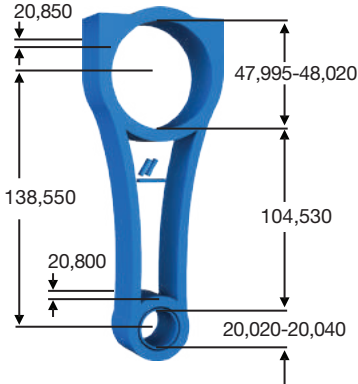

Engine Type	Models	Picture	Sizes (mm)	Products	BMY Reference
<b>1</b> Porsche M96.01 M96.02 M96.04  3.4 cc B6  Porsche M96.03 M96.05  3.6 cc  B6	Boxter, Cayman, Tagra, 911		<p>720 gr   Torque : 70 Nm</p>	Connecting Rod STD  Connecting Rod SEMI  Bushing Bimetal Locked-Straight  Bolt - 10.9 M9x1 L:57 mm  Con. Rod OEM : 9961031025R, 9961031026R, 9961031028R	<b>BMY0501</b> 1 pc.24x10x4cm  <b>BMY0501SEMI</b> 1 pc.24x10x4cm  <b>BMY0501B</b> 6 pcs. 10x6x4cm
<b>2</b> Porsche M96.22 M96.23 M97.20  2.7 cc  B6	Boxter, Cayman, Tagra		<p>610 gr   Torque : 70 Nm</p>	Connecting Rod STD  Connecting Rod SEMI  Bushing Bimetal Locked-Straight  Bolt - 10.9 M9x1 L:57 mm  Con. Rod OEM : 9961031102R	<b>BMY0502</b> 1 pc.24x10x4cm  <b>BMY0502SEMI</b> 1 pc.24x10x4cm  <b>BMY0501B</b> 6 pcs. 10x6x4cm

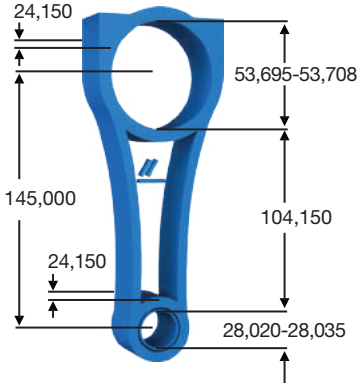





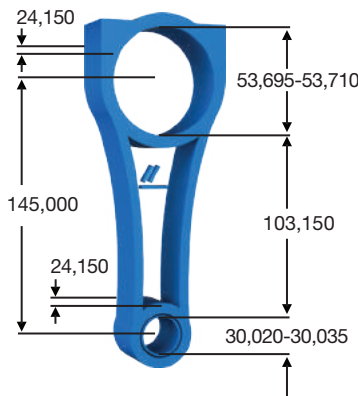

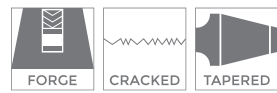
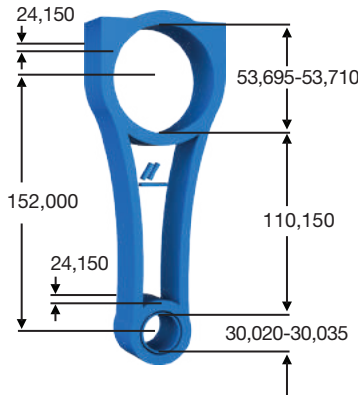
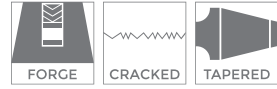

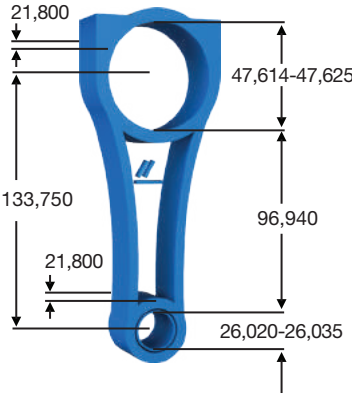

Engine Type	Models	Picture	Sizes (mm)	Products	BMY Reference
<b>1</b> Peugeot DW8/ XUD9, A, Z, B  1.9 cc  R4	Peugeot Partner, Boxer, 306, 406		 <p>715 gr   Torque : 60 Nm</p>	Connecting Rod STD	<b>BMY0801</b> 1 pc.24x10x4cm
	Citroen Jumper, Jumpy  Fiat Scudo, Ducato  Suzuki Baleno			Connecting Rod SEMI	<b>BMY0801SEMI</b> 1 pc.24x10x4cm
				Bushing Bimetal Locked-Straight	<b>BMY0801B</b> 4 pcs. 10x6x4cm
				Bolt - 10.9 M9x1 L:46 mm	
				Con. Rod OEM : 0603 77	
					
<b>2</b> Peugeot Sofim S8U, S9U  2.5 cc  R4	Peugeot Boxer		 <p>1320 gr   Torque : 80 Nm</p>	Connecting Rod STD	<b>BMY0802</b> 1 pc.24x10x4cm
				Connecting Rod SEMI	<b>BMY0802SEMI</b> 1 pc.24x10x4cm
				Bushing Bimetal Locked-Straight	<b>BMY0803B</b> 4 pcs. 10x6x4cm
				Bolt - 10.9 M10x1,25 L: 58 mm	
				Con. Rod OEM : 7473171	
					
<b>3</b> Peugeot Sofim S8W, S9W  2.8 cc  R4	Peugeot Boxer		 <p>1290 gr   Torque : 80 Nm</p>	Connecting Rod STD	<b>BMY0803</b> 1 pc.24x10x4cm
				Connecting Rod SEMI	<b>BMY0803SEMI</b> 1 pc.24x10x4cm
				Bushing Bimetal Locked-Straight	<b>BMY0803B</b> 4 pcs. 10x6x4cm
				Bolt - 10.9 M10x1,25 L: 58 mm	
				Con. Rod OEM : 500 352 497	
					

Engine Type	Models	Picture	Sizes (mm)	Products	BMY Reference
<b>4</b> Peugeot 4HG 110ps 4HH 130ps 4HJ 150ps 2.2 cc R4	Peugeot Boxer Citroen Jumper			Connecting Rod STD Connecting Rod SEMI Bushing Bimetal Locked-Straight Bolt - 10.9 M9x1 L:46 mm	<b>BMY0804</b> 1 pc.24x10x4cm <b>BMY0804SEMI</b> 1 pc.24x10x4cm <b>BMY0804B</b> 4 pcs. 10x6x4cm <b>BMY0805CB</b> 8 pcs. 10x6x4cm
 			882 gr   Torque : 60 Nm 2nd Torque Option : 30 Nm+100 °		Con. Rod OEM : 0603 E3/E4/E5
<b>5</b> Peugeot 4HU, 120ps 4HV 100ps Fiat 4HU 120ps 4HV 100ps 2.2 cc R4	Peugeot Boxer Citroen Jumper			Connecting Rod STD Connecting Rod SEMI Bushing Bimetal Locked-Straight Bolt - 10.9 M9x1 L:42 mm	<b>BMY0805</b> 1 pc.24x10x4cm <b>BMY0805SEMI</b> 1 pc.24x10x4cm <b>BMY0805B</b> 4 pcs. 10x6x4cm <b>BMY0805CB</b> 8 pcs. 10x6x4cm
 			873 gr   Torque : 60 Nm 2nd Torque Option : 30 Nm+100 °		Con. Rod OEM PSA : 0603 97/98 Con. Rod OEM FIAT : 9659672280, 9661857980, 9661858180, 9667060880, 9667061080
<b>6</b> Peugeot DV4 TD/TED4 1.4 cc R4	Peugeot 206, 207, 1007 Ford Fiesta, Fusion Citroen C1, C2, C3, Xsara Mazda 2 Suzuki Liana Toyota Aygo			Connecting Rod STD Connecting Rod SEMI Bushing Bimetal Locked-Straight Bolt - 10.9 M7x1 L: 38 mm	<b>BMY0806</b> 1 pc.24x10x4cm <b>BMY0806SEMI</b> 1 pc.24x10x4cm <b>BMY0806B</b> 4 pcs. 10x6x4cm <b>BMY0806CB</b> 8 pcs. 10x6x4cm
			500 gr   Torque : 45 Nm 2nd Torque Option : 5 Nm + 10 Nm + 130 °		Con. Rod OEM : 0603 88

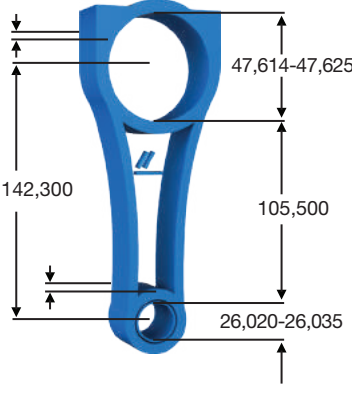

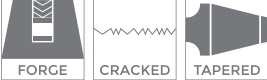

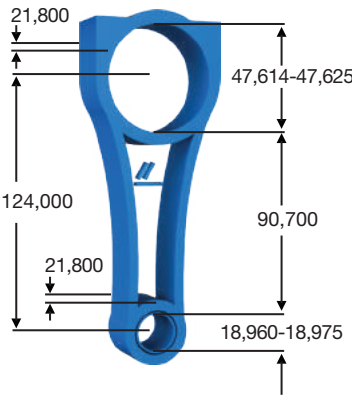

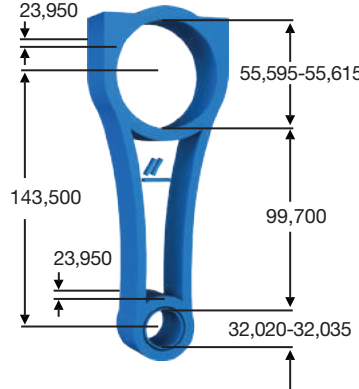

Engine Type	Models	Picture	Sizes (mm)	Products	BMY Reference
<b>7</b> Peugeot DV6 ATED4B, TED4C 1.6 cc R4	Peugeot 207, 307, 308, 407, Partner, 508 Citroen C3, C4, Berlingo			Connecting Rod STD	<b>BMY0807</b> 1 pc.24x10x4cm
	Ford C-Max, Focus, Fiesta MINI Cooper D Mazda 2, 3 Volvo C30, S40, V50/60, S60 Suzuki SX4			Connecting Rod SEMI	<b>BMY0807SEMI</b> 1 pc.24x10x4cm
				Bushing Bimetal Locked-Straight	<b>BMY0807B</b> 4 pcs. 10x6x4cm
				Bolt - 10.9 M7x1 L: 38 mm	<b>BMY0806CB</b> 8 pcs. 10x6x4cm
				Con. Rod OEM : 060392 - 0603C0	
			600 gr   Torque : 45 Nm 2nd Torque Option : 5 Nm + 10 Nm + 130 °		
				  	
<b>8</b> PSA EP6, EP6C EP6DT, EP6CDTX BMW MINI N13 B16 N14 B16 N18 B16 1.6 cc R4	Peugeot 207, 208, 2008, 308, 3008, 508			Connecting Rod STD	<b>BMY0808</b> 1 pc.24x10x4cm
	Citroen C4, DS3, DS4, C3			Connecting Rod SEMI	<b>BMY0808SEMI</b> 1 pc.24x10x4cm
				Bushing Bimetal Locked-Straight	<b>BMY0808B</b> 4 pcs. 10x6x4cm
				Bolt - 10.9 M7x1 L: 38 mm	<b>BMY0806CB</b> 8 pcs. 10x6x4cm
				Con. Rod OEM : 0603 96, 161 366 51 80 11247621253 BMW	
			465 gr   Torque : 45 Nm 2nd Torque Option : 5 Nm + 15 Nm + 130 °		
				  	
<b>9</b> Peugeot DW10BTED4/ RHK/ RHR/RHF/ RHJ/FD/FC Volvo D4204T/ D4204T2 2.0 cc R4	Peugeot Partner/Berlingo 307, 407, 607, 807 308, 508			Connecting Rod STD	<b>BMY0810</b> 1 pc.24x10x4cm
	Volvo C30, C70, S40, V50, S80, V70 2.0D			Connecting Rod SEMI	<b>BMY0810SEMI</b> 1 pc.24x10x4cm
				Bushing Bimetal Locked-Straight	<b>BMY0810B</b> 4 pcs. 10x6x4cm
				Bolt - 10.9 M9x1 L:56 mm	
				Con. Rod OEM : 0603 90 - 0603 A6	
			780 gr   Torque : 70 Nm		
				  	

Engine Type	Models	Picture	Sizes (mm)	Products	BMY Reference
<b>10</b> Peugeot DW10CTED4, DW10FUD RHH, RHE, RH02  2.0 cc  R4	Peugeot 308, 407, 508, 3008, 5008, RCZ, Partner  Citroen C4, C5, DS4, DS5, Berlingo, Jumpy, Xsara  Ford Focus, C-Max, Transit Panther C		  790 gr   Torque : 60 Nm	Connecting Rod STD  Connecting Rod SEMI  Bushing Bimetal Locked-Straight  Bolt - 10.9 M9x1 L:46 mm	<b>BMY0811</b> 1 pc.24x10x4cm  <b>BMY0811SEMI</b> 1 pc.24x10x4cm  <b>BMY0811B</b> 4 pcs. 10x6x4cm  Con. Rod OEM : 0603 C5, 1613238180, 1406651180, 1606651180
					
<b>11</b> Peugeot/Citroen/ Opel/Fiat/ Lancia/ Tata/Vauxhall/ Ford DW12C/ FUD/RU/RUC/ RUD/RUE/ MTED4/BTED4/ UTED/ME5/ TED4/DD  Land Rover/ Jaguar 224DT  2.2 cc  R4	406, 508, 607, 807, Boxer C5, C6, C8, Xsara, Jumper Range Rover Evoque, Freelander II, Discovery Sport XF, XFI, XF Sportbrake  Phedra  Ulysse		  790 gr   Torque : 60 Nm	Connecting Rod STD  Connecting Rod SEMI  Bushing Bimetal Locked-Straight  Bolt - 10.9 M9x1 L:46 mm	<b>BMY0812</b> 1 pc.24x10x4cm  <b>BMY0812SEMI</b> 1 pc.24x10x4cm  <b>BMY0811B</b> 4 pcs. 10x6x4cm  Con. Rod OEM : 0603 95, 0603 C3, 9688244280, 9688245380, 9833274780 (L.Rover: LR001227, LR019693, LR051836)
					

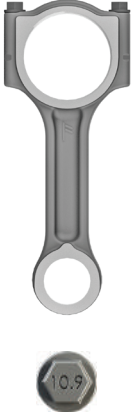
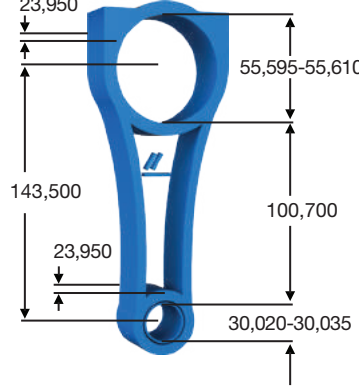

Engine Type	Models	Picture	Sizes (mm)	Products	BMY Reference
<b>1</b> Renault K9K 1.5 cc R4	Renault Clio, Kangoo,Fluence Megane, Latitude, Laguna, Captur Dacia Logan, Sandero, Duster  Nissan Micra, Qashqai, Juke Mercedes-Benz Citan, A-B-CLA 180 CDI Suzuki Jimny			Connecting Rod STD  Connecting Rod SEMI  Bushing Bimetal Locked-Straight  Bolt - 10.9 M9x1 L:42 mm	<b>BMY0901</b> 1 pc.24x10x4cm  <b>BMY0901SEMI</b> 1 pc.24x10x4cm  <b>BMY0901B</b> 4 pcs. 10x6x4cm  <b>BMY0901CB</b> 8 pcs. 10x6x4cm
 			535 gr   Torque : 60 Nm 2nd Torque Option : 20 Nm + 45 °		Con. Rod OEM : 770 147 5074
<b>2</b> Renault K9K 846, K9K 608, 872  Mercedes-Benz OM607, OM608  1.5 cc - R4  Euro 5/6	Renault Megane IV, Kadjar, Scenic IV, Clio Captur  Mercedes-Benz A, B, CLA, GLA Class, Citan  Infiniti Q30  Nissan Note, Micra  Dacia Lodgy			Connecting Rod STD  Connecting Rod SEMI  Bushing Bimetal Locked-Straight  Bolt - 10.9 M9x1 L:42 mm	<b>BMY0902</b> 1 pc.24x10x4cm  <b>BMY0902SEMI</b> 1 pc.24x10x4cm  <b>BMY0901B</b> 4 pcs. 10x6x4cm  <b>BMY0901CB</b> 8 pcs. 10x6x4cm
 			560 gr   Torque : 60 Nm 2nd Torque Option : 20 Nm + 45 °		Con. Rod OEM : 121008820R, 607 030 0420, 6070302100, 12100-00QAJ, 12100-00Q1J
<b>3</b> Renault, Dacia E7J  1,4 cc  R4  Fuel injected	Renault 9, 19, Clio I, II, Megane I, Express, Kangoo  Dacia Solenza, SupeRNova			Connecting Rod STD    Bolt - 10.9 M9x1 L:42 mm	<b>BMY0903</b> 1 pc.24x10x4cm    <b>BMY0903CB</b> 8 pcs. 10x6x4cm
			510gr   Torque : 60 Nm		Con. Rod OEM : 7701465085, 8200454199

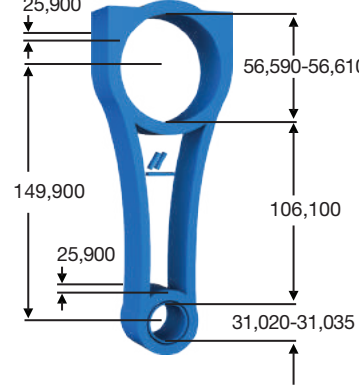









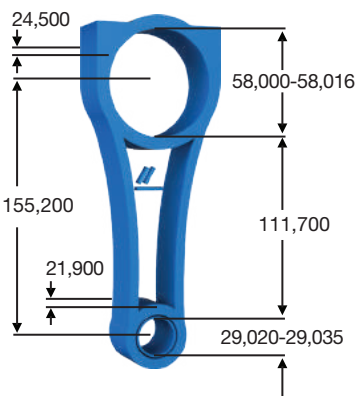





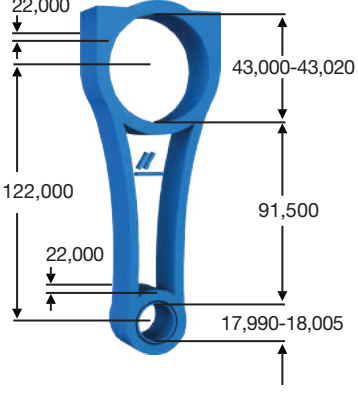

Engine Type	Models	Picture	Sizes (mm)	Products	BMY Reference	
<b>4</b> Renault/Nissan R9M Mercedes-Benz OM626 Fiat/Opel/Vauxhall R9M  1.6 cc  R4  Long Type Langer Typ Uzun Tip	Talisman, Fluence, Megane, Traffic Scenic, Koleos, Espace  Qashqai, Juke X-Trail, NV300,  C Class  Vivaro  Talento		675 gr   Torque : 60Nm 2nd Torque Option : 20Nm+45°	Connecting Rod STD <b>BMY0904</b> 1 pc.24x10x4cm  Connecting Rod SEMI <b>BMY0904SEMI</b> 1 pc.24x10x4cm  Bushing Bimetal Locked-Straight <b>BMY0916B</b> 4 pcs. 10x6x4cm  Bolt - 10.9 M9x1 L:42 mm <b>BMY0901CB</b> 8 pcs. 10x6x4cm  Con. Rod OEM : 121001039R, 121004759R, 1210000Q1H, 626 030 0420		
<b>5</b> Renault G9U  2.5 cc  R4	Renault Master II, Laguna Nissan Interstar Opel Movano		870 gr   Torque : 60 Nm 2nd Torque Option : 20 Nm + 45 °	Connecting Rod STD <b>BMY0913</b> 1 pc.24x10x4cm  Connecting Rod SEMI <b>BMY0913SEMI</b> 1 pc.24x10x4cm  Bushing Bimetal Locked-Straight <b>BMY0913B</b> 4 pcs. 10x6x4cm  Bolt - 10.9 M9x1 L:42 mm <b>BMY0901CB</b> 8 pcs. 10x6x4cm  Con. Rod OEM : 770 147 3615		
<b>6</b> Renault F9Q  1.9 cc  R4	Renault Master, Traffic, Laguna, Kangoo, Megane, Clio  Opel Vivaro  Mitsubishi Carisma, Spacestar  Volvo S40 Suzuki Grand Vitara		670 gr   Torque : 60 Nm 2nd Torque Option : 20 Nm + 45 °	Connecting Rod STD <b>BMY0914</b> 1 pc.24x10x4cm  Connecting Rod SEMI <b>BMY0914SEMI</b> 1 pc.24x10x4cm  Bushing Bimetal Locked-Straight <b>BMY0914B</b> 4 pcs. 10x6x4cm  Bolt - 10.9 M9x1 L:42 mm <b>BMY0901CB</b> 8 pcs. 10x6x4cm  Con. Rod OEM : 770 147 6250		



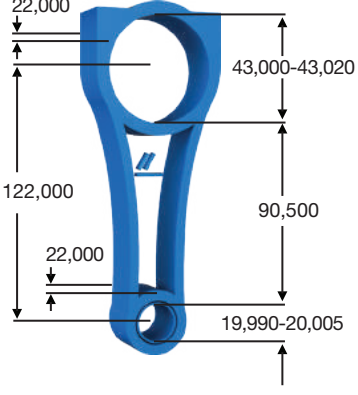







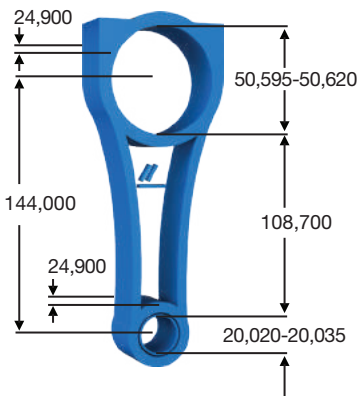

Engine Type	Models	Picture	Sizes (mm)	Products	BMY Reference
<b>7</b> Renault M9R 2.0 cc R4	Renault Megane, Laguna, Master, Trafic			Connecting Rod STD	<b>BMY0915</b> 1 pc.24x10x4cm
	Nissan Qashqai, X-Trail			Connecting Rod SEMI	<b>BMY0915SEMI</b> 1 pc.24x10x4cm
				Bushing Bimetal Locked-Straight	<b>BMY0915B</b> 4 pcs. 10x6x4cm
				Bolt - 10.9 M9x1 L:42 mm	<b>BMY0901CB</b> 8 pcs. 10x6x4cm
				Con. Rod OEM : 770 147 7831	
					
<b>8</b> Renault M9R 2.0 cc R4	Renault Megane, Laguna, Master, Trafic			Connecting Rod STD	<b>BMY0916</b> 1 pc.24x10x4cm
	Nissan Qashqai, X-Trail			Connecting Rod SEMI	<b>BMY0916SEMI</b> 1 pc.24x10x4cm
				Bushing Bimetal Locked-Straight	<b>BMY0916B</b> 4 pcs. 10x6x4cm
				Bolt - 10.9 M9x1 L:42 mm	<b>BMY0901CB</b> 8 pcs. 10x6x4cm
				Con. Rod OEM : 7701476577, 12100-00Q0A	
					
<b>9</b> Renault G9T 2.2 cc R4	Renault Laguna, Espace, Master, Trafic, Vel Satis			Connecting Rod STD	<b>BMY0917</b> 1 pc.24x10x4cm
	Opel/Vauxhall Movano, Vivaro			Connecting Rod SEMI	<b>BMY0917SEMI</b> 1 pc.24x10x4cm
				Bushing Bimetal Locked-Straight	<b>BMY0913B</b> 4 pcs. 10x6x4cm
				Bolt - 10.9 M9x1 L:42 mm	<b>BMY0901CB</b> 8 pcs. 10x6x4cm
				Con. Rod OEM : 770 147 2847	
					



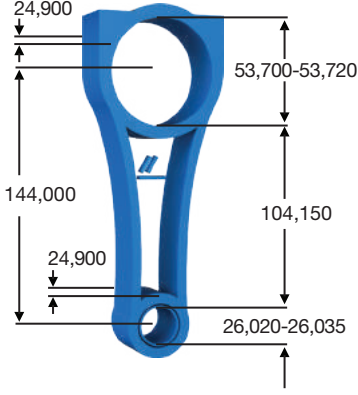

Engine Type	Models	Picture	Sizes (mm)	Products	BMY Reference
<b>10</b> Renault M9T 2.3 cc R4	Renault Master, Koleos, Alaskan  Opel/Vauxhall Movano  Nissan NV400, Navara, Qashqai, X-Trail, Primastar  Mercedes-Benz X-Class			Connecting Rod STD  Connecting Rod SEMI  Bushing Bimetal Locked-Straight  Bolt - 10.9 M9x1 L:42 mm	<b>BMY0918</b> 1 pc.24x10x4cm  <b>BMY0918SEMI</b> 1 pc.24x10x4cm  <b>BMY0915B</b> 4 pcs. 10x6x4cm  <b>BMY0901CB</b> 8 pcs. 10x6x4cm
			805 gr   Torque : 60 Nm 2nd Torque Option : 20 Nm + 45 °		
<b>11</b> Renault R9M  Mercedes-Benz OM626  1.6 cc  R4	Renault Talisman, Fluence  Dacia Duster, Logan, Sandero  Mercedes-Benz A, B, C, CLA-Class, Citan  Nissan Juke, Almera, Cube, Micra, Note			Connecting Rod STD  Connecting Rod SEMI  Bushing Bimetal Locked-Straight  Bolt - 10.9 M9x1 L:42 mm	<b>BMY0919</b> 1 pc.24x10x4cm  <b>BMY0919SEMI</b> 1 pc.24x10x4cm  <b>BMY0916B</b> 4 pcs. 10x6x4cm  <b>BMY0901CB</b> 8 pcs. 10x6x4cm
			655 gr   Torque : 60 Nm 2nd Torque Option : 20 Nm + 45 °		
<b>12</b> Renault K4M 1.6  K4J 1.4  C1J, C2J, C3J, C6J, C2L  810 01/02/03/05/06 842 01, 847 05/06  Volvo B14, B14E	Renault Clio I/III, Kangoo, Scenic I/II, Megane I/II, Laguna, Modüs, R9, R12  Volvo 340, 343, 345			Connecting Rod STD  Bolt - 10.9 M9x1 L:42 mm	<b>BMY0921</b> 1 pc.24x10x4cm
			550gr   Torque : 60 Nm		
				Con. Rod OEM : 7701471281, 121009455R, 7701477612, 6001543049	

Engine Type	Models	Picture	Sizes (mm)	Products	BMY Reference
<p><b>13</b></p> <p>Renault K7M 1.6 K7J 1.4 E6J 1.4 E5F 1.2 E7F 1.2</p>	<p>Renault Clio, Megane II/Coupe, 19, Express</p> <p>Dacia Logan, Solenza</p>		<p>21,850</p> <p>47,614-47,625</p> <p>128,000</p> <p>94,000</p> <p>21,850</p> <p>19,000</p> <p>530gr   Torque : 60 Nm</p>	<p>Connecting Rod STD</p> <p>Bolt - 10.9 M9x1 L:42 mm</p> <p>Con. Rod OEM : 121000999R, 7701476393</p>	<p><b>BMY0922</b> 1 pc.24x10x4cm</p>
<p><b>14</b></p> <p>Renault, Nissan, Infiniti V9X</p> <p>3.0 cc</p> <p>V6</p>	<p>Renault Laguna III, Latitude</p> <p>Nissan Navara, Pathfinder</p> <p>Infiniti QX70D, FX30d, EX30d, M30d</p>		<p>19,500</p> <p>71,500-71,520</p> <p>155,500</p> <p>103,750</p> <p>24,000</p> <p>32,020-32,040</p> <p>904gr   Torque : 60 Nm</p>	<p>Connecting Rod STD</p> <p>Connecting Rod SEMI</p> <p>Bushing Bimetal Locked-Straight</p> <p>Bolt - 10.9 M9x1 L:50 mm</p> <p>Con. Rod OEM : 7701478766</p>	<p><b>BMY0923</b> 1 pc.30x12x4cm</p> <p><b>BMY0923SEMI</b> 1 pc.30x12x4cm</p> <p><b>BMY0915B</b> 4 pcs. 10x6x4cm</p> <p><b>BMY0901CB</b> 8 pcs. 10x6x4cm</p>



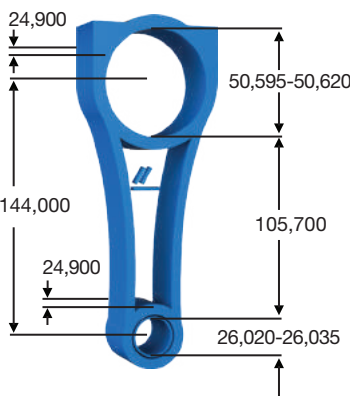

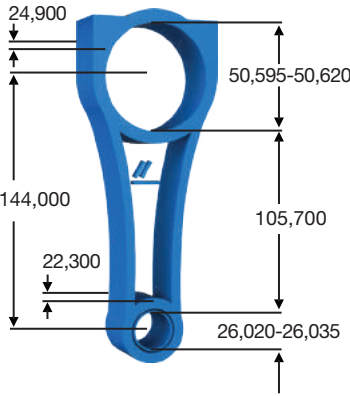

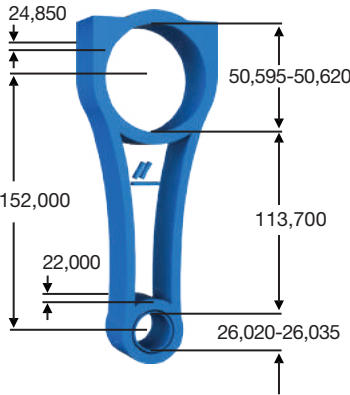



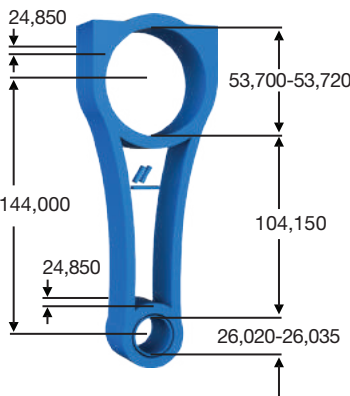









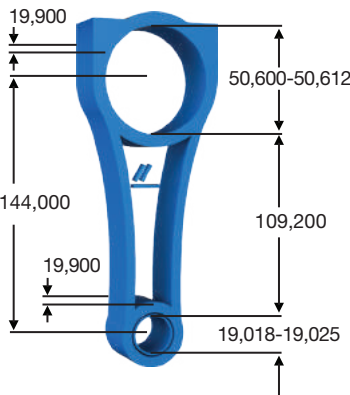







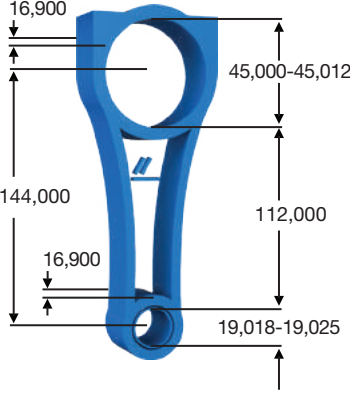









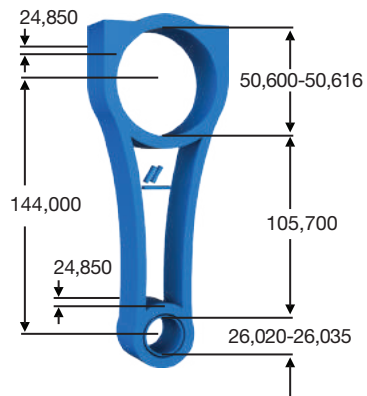



Engine Type	Models	Picture	Sizes (mm)	Products	BMY Reference
<b>1</b> Toyota Lexus 1VD-FTV Euro 4  4.5 cc  V8	Land Cruiser  LX		 <p>780gr   Torque : 60 Nm</p>	Connecting Rod STD  Connecting Rod SEMI  Bushing Bimetal Locked-Straight  Bolt - 10.9 M9x1 L:42 mm  Con. Rod OEM : 13201-51021-B0	<b>BMY1901</b> 1 pc.24x10x4cm  <b>BMY1901SEMI</b> 1 pc.24x10x4cm  <b>BMY1901B</b> 4 pcs. 10x6x4cm
 				  	
<b>2</b> Toyota 4A-F  1.6 cc  R4	Corolla, Carina, Celica		 <p>460 gr   Torque : 60 Nm</p>	Connecting Rod STD   Bolt - 10.9 M9x1 L:42 mm  Con. Rod OEM : 13201-19056	<b>BMY1902</b> 1 pc.24x10x4cm
 				  	
<b>3</b> Toyota 4A-FE  1.6 cc  R4	Corolla, Carina, Celica, Avensis		 <p>475 gr   Torque : 60 Nm</p>	Connecting Rod STD   Bolt - 10.9 M9x1 L:42 mm  Con. Rod OEM : 13201-19135	<b>BMY1903</b> 1 pc.24x10x4cm
 				  	

Engine Type	Models	Picture	Sizes (mm)	Products	BMY Reference
<b>1</b> Volkswagen APT, AGN, ARG APU, AWU, AUM, AEB, BJX, BKF 1.8 cc R4	Volkswagen Passat, Golf Bora, Jetta Audi A3, A4, A6, TT Seat Leon, Toledo, Ibiza Skoda Octavia, Superb		 <p>560 gr   Torque : 50 Nm</p>	Connecting Rod STD Connecting Rod SEMI Bushing Bimetal Locked-Straight Bolt w. Nut- 12.9 M8x1 L:54 mm	<b>BMY1001</b> 1 pc.24x10x4cm <b>BMY1001SEMI</b> 1 pc.24x10x4cm <b>BMY1001B</b> 4 pcs. 10x6x4cm Con. Rod OEM : 027 198 401 B 027 198 401 D
 	  				
<b>2</b> Volkswagen/Audi Seat/Skoda, AXD, AXE, AZV, BAC, BGW, BHW, BJJ, BJK, BJL, BJM, BKD, BLJ, BLK, BMM, BMN, BMP, BNZ, BPC, BPD, BPW, BPE, BPZ, BRT, BSS, BSV, BVH, BWW, CAAA, CAAB, CAAC, CAAD, CAAE, CBAA, CBAB, CBAC, CBBA, CBBB, CBDA, CBDB, CBDC, CBEA, CBHA, CBJA, CBJB, CBKA, CCHA, CCHB, CDBA, CDCA, CEBA, CEBB, CECA, CECB, CEGA, CFCA, CFFA, CFFB, CFFD, CFFE, CFGB, CFGC, CFGD, CFHA, CFHB, CFHC, CFHD, CFHE, CFHF, CFJA, CFJB, CJAA, CJDA, CJDD, CKRA, CKTB, CKTC, CKUB, CKUC, CLCA, CLCB, CLJA, CLLA, CLLB, CNEA, CNFA, CNFB, CSHA, CSLB, CSNA 2.0 - 2.5 cc R4	Volkswagen Crafter, Passat, Transporter Audi A4, A6, A8 Seat Toledo, Leon Skoda Octavia, Superb		 <p>670 gr   Torque : 50 Nm  2nd Torque Option :  30 Nm + 90 °</p>	Connecting Rod STD Connecting Rod SEMI Bushing Bimetal Locked-Straight Bolt - 10.9 M8x1 L:44 mm	<b>BMY1002</b> 1 pc.24x10x4cm <b>BMY1002SEMI</b> 1 pc.24x10x4cm <b>BMY1002B</b> 4 pcs. 10x6x4cm <b>BMY1002CB</b> 8 pcs. 10x6x4cm Con. Rod OEM : 038 105 401 J 038 198 401 D, 038 198 401 E, 038 198 401 F
  	  				

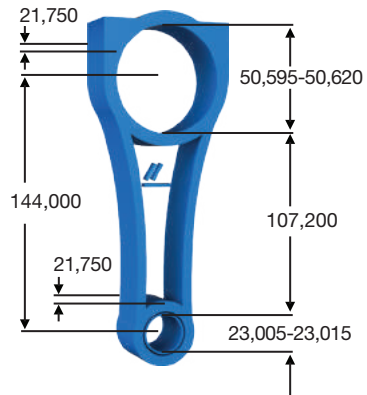













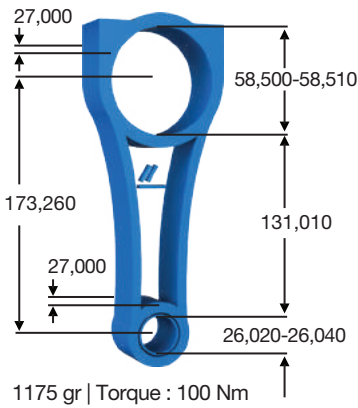

Engine Type	Models	Picture	Sizes (mm)	Products	BMY Reference
<b>3</b> Volkswagen BSU, ATJ, BRU, BSW, AUJ, ARL, ANU, BTB, AVQ, AVB, BLS, BXE, BXF, BXJ, BMT Audi ANU, ATJ, AVB Seat BJB, BLS, BXE, BXF, BXJ Skoda BJB, BLS, BXE  1.9 cc  R4	Volkswagen Caddy, Passat, Jetta, Bora, Touran Audi A4, A6 Seat Toledo, Leon, Altea, Ibiza  Skoda Octavia, Superb		 <p>24,900 50,595-50,620 144,000 105,700 24,900 26,020-26,035</p> <p>635 gr   Torque : 50 Nm 2nd Torque Option : 30 Nm + 90 °</p>	Connecting Rod STD Connecting Rod SEMI Bushing Bimetal Locked-Straight Bolt - 10.9 M8x1 L:44 mm Con. Rod OEM : 038 105 401 G, 038 198 401 H	<b>BMY1003</b> 1 pc.24x10x4cm  <b>BMY1003SEMI</b> 1 pc.24x10x4cm  <b>BMY1002B</b> 4 pcs. 10x6x4cm  <b>BMY1002CB</b> 8 pcs. 10x6x4cm
<b>4</b> Volkswagen Audi/Seat BAY, BMS, BNM BNV, BWB, AMF, CUSA, CUSB, CUTA  1.4 cc  R3	Volkswagen Polo, Lupo  Audi A2  Seat Ibiza, Leon		 <p>24,900 50,595-50,620 144,000 105,700 22,300 26,020-26,035</p> <p>610 gr   Torque : 50 Nm 2nd Torque Option : 30 Nm + 90 °</p>	Connecting Rod STD Connecting Rod SEMI Bolt - 10.9 M8x1 L:44 mm Con. Rod OEM : 045 198 401 B , 045 198 401 C, 045 198 401 A, 04B 105 401, 045 198 401 B/C	<b>BMY1004</b> 1 pc.24x10x4cm  <b>BMY1004SEMI</b> 1 pc.24x10x4cm  <b>BMY1002CB</b> 8 pcs. 10x6x4cm
<b>5</b> Volkswagen Audi/Seat/Skoda CAYA, CAYB, CAYC, CAYE, CLHA, CRKA, CFWA  1,2 - 1,6 cc  R3 - R4	Volkswagen Caddy, Golf Jetta, Passat Polo 1.2TDI  Audi A3  Seat Ibiza, Leon  Skoda Octavia, Superb		 <p>24,850 50,595-50,620 152,000 113,700 22,000 26,020-26,035</p> <p>630 gr   Torque : 50 Nm 2nd Torque Option : 30 Nm + 90 °</p>	Connecting Rod STD Connecting Rod SEMI Bushing Bimetal Locked-Straight Bolt - 10.9 M8x1 L:44 mm Con. Rod OEM : 03L 105 401 A	<b>BMY1005</b> 1 pc.24x10x4cm  <b>BMY1005SEMI</b> 1 pc.24x10x4cm  <b>BMY1002B</b> 4 pcs. 10x6x4cm  <b>BMY1002CB</b> 8 pcs. 10x6x4cm

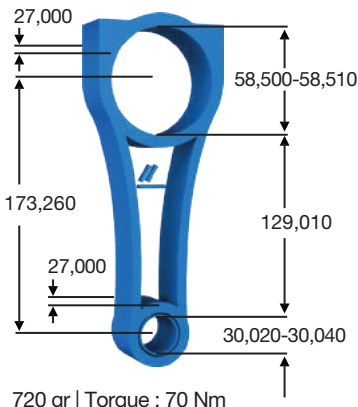
Engine Type	Models	Picture	Sizes (mm)	Products	BMY Reference		
<b>6</b> Volkswagen Audi CR, CS, CY, JX, KY, ME, MF, SB, 68A, 68B, 68C, ADK  1,6 - 1,7 cc  R4	Volkswagen T3, Golf, Jetta, Santana, Rabbit  Audi 80, 90,  4000		<p>24,900 50,595-50,620 136,000 98,700 24,900 24,020-24,035</p> <p>630 gr   Torque : 60 Nm</p>	Connecting Rod STD  Bushing Bimetal Locked-Straight  Bolt - 10.9 M9x1 L : 46mm	<b>BMY1006</b> 1 pc.24x10x4cm  <b>BMY1006B</b> 4 pcs. 10x6x4cm  Con. Rod OEM : 068 198 401 D		
		<b>7</b> Volkswagen BZB, CABD, CDAA, CDAB, CDHA, CDHB, CJEB, CHED, CJEE, CJSA, CJSB, CJSC, CNSA, CNSB, CPKA, CPRA, CYGA, DAJA, DAJB,  1,8 cc TFSI  R4	Volkswagen Passat, Jetta, Polo, Golf, Beetle, CC, Sharan  Audi A1, A3, A4, A5, A6, TT  Skoda Superb, Octavia, Yeti  Seat Altea, Leon, Toledo, Exeo, Alhambra		<p>21,750 50,595-50,620 148,000 111,200 21,750 23,005-23,015</p> <p>565 gr   Torque : 50 Nm</p>	Connecting Rod STD  Bolt - 10.9 M8x1 L:47 mm  Con. Rod OEM : 06J 198 401 H, 06J 198 401 D	
		<b>8</b> Volkswagen Seat/Skoda BZB, CEA, CEAA, CGYA, BYJ  Audi BYT, BZB, CABA, CABB, CABD  1,8 cc TSI, TFSI  R4	Volkswagen Tiguan, Passat, CC  Audi A3, A4, A5  Skoda Superb, Octavia  Seat Altea/XL, Leon, Toledo  VW FAW Magotan, Sagitar		<p>21,800 50,595-50,620 148,000 112,200 19,950 21,012-21,018</p> <p>520 gr   Torque : 50 Nm</p>	Connecting Rod STD  Connecting Rod SEMI  Bushing Bimetal Locked-Straight  Bolt - 10.9 M8x1 L: 47 mm  Con. Rod OEM : 06H 198 401 Q, 06J 198 401 F, 06J 198 401 K	

Engine Type	Models	Picture	Sizes (mm)	Products	BMY Reference
<b>9</b> Volkswagen/ Audi/Skoda CNHA, CNHC, CRLB, CRLD, DDAA  2,0 cc  R4	Golf VII, Golf Van, Passat, Passat Alltrack, Transporter, Multivan A3, A4 Avant, A4  Allroad, A5, A6, A6 Avant, A6  Allroad, Q5 Superb III		 640 gr   Torque : 50 Nm 2nd Torque Option : 30 Nm + 90 °	Connecting Rod STD  Connecting Rod SEMI  Bushing Bimetal Locked-Straight  Bolt - 10.9 M8x1 L:44 mm  Con. Rod OEM: 04L 105 401 A (04LA)	<b>BMY1009</b> 1 pc.24x10x4cm  <b>BMY1009SEMI</b> 1 pc.24x10x4cm  <b>BMY1002B</b> 4 pcs. 10x6x4cm  <b>BMY1002CB</b> 8 pcs. 10x6x4cm
     	  				
<b>10</b> Volkswagen BLG, BMY, BWK, CAVA, CAVB, CAVC, CAVD, CAVE, CAXA, CDGA, CKMA, CMSB, CNWA, CTHA, CTHB, CTHC, CTHD, CTHE, CTKA, DAGA, Audi CAVG, CAXA, CAXC, CNVA, CTHG, Seat CAVA, CAVE, CAVF, CAXA, CAXC, CNUB, CNWB, CTHA, CTHE, CTHF, CTJB, CTJC Skoda CAVE, CAXA, CAXC, CTHE  1,4 cc TSI  R4	Volkswagen Touran, Golf, Polo, Tiguan, Passat, Jetta, Scirocco, Sharan, Beetle, Eos, CC  Audi A1, A3  Seat Ibiza, Toledo, Leon Alhambra, Altea  Skoda Yeti, Rapid, Octavia, Superb, Fabia  VW FAW Sagitar		 514 gr   Torque : 50 Nm 2nd Torque Option : 30 Nm + 90 °	Connecting Rod STD  Connecting Rod SEMI  Bushing Bimetal Locked-Straight  Bolt - 10.9 M8x1 L:44 mm  Con. Rod OEM : 03C 198 401 A, 03C 198 401 D	<b>BMY1010</b> 1 pc.24x10x4cm  <b>BMY1010SEMI</b> 1 pc.24x10x4cm  <b>BMY1010B</b> 4 pcs. 10x6x4cm  <b>BMY1002CB</b> 8 pcs. 10x6x4cm
  	  				
<b>11</b> Volkswagen CBZA, CBZB, CYA, CYVB, DJN Audi CBZA, CBZB, CYVA, Seat CBZA, CBZB Skoda CBZA, CBZB, CYVA, DJNB  1,2 cc TSI  R4	Volkswagen Touran, Sharan, Jetta, Golf, Beetle, Polo, Caddy Audi A1, A3 Seat Ibiza, Toledo, Leon, Altea Skoda Roomster, Yeti, Fabia, Octavia, Rapid		 427 gr   Torque : 50 Nm 2nd Torque Option : 30 Nm + 90 °	Connecting Rod STD  Connecting Rod SEMI  Bushing Bimetal Locked-Straight  Bolt - 10.9 M8x1 L:44 mm  Con. Rod OEM : 03F 198 401	<b>BMY1011</b> 1 pc.24x10x4cm  <b>BMY1011SEMI</b> 1 pc.24x10x4cm  <b>BMY1011B</b> 4 pcs. 10x6x4cm  <b>BMY1002CB</b> 8 pcs. 10x6x4cm
  	  				

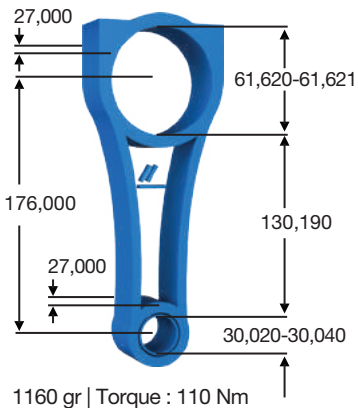
Engine Type	Models	Picture	Sizes (mm)	Products	BMY Reference
<b>12</b> Volkswagen/ ACV, ACV, AGX, AHD, AHY, AJT, ANF, ANG, ANH, ANJ, APA, AUF, AVR, AFN, AVG Audi 1T, AAT, ABP, AEL  2.5cc TDI  R5	LT28, LT35, Transporter T4 A6, A6 Avant, 100		 <p>670 gr   Torque : 50 Nm</p>	Connecting Rod STD  Connecting Rod SEMI  Bushing Bimetal Locked-Straight  Bolt - 10.9 M8x1 L:44 mm	<b>BMY1012</b> 1 pc.24x10x4cm  <b>BMY1012SEMI</b> 1 pc.24x10x4cm  <b>BMY1012B</b> 4 pcs. 10x6x4cm  <b>BMY1002CB</b> 8 pcs. 10x6x4cm
  	  				
<b>13</b> Volkswagen/ Seat, Skoda CAWA, CAWB, CBFA, CCTA, CCZA, CCZB, CCZC, CCZD, CDAB, CFPA, CHHA, CHHB, CJK A, CJKB, CJXA, CJXB, CJXC, CJXD, CJXE, CJXG, CNTC, CULA, CULC, CYFB, CZPA, CZPB, DEDA, DJHA, CHHB  Audi CPMB, CPSA, CULB, CULC, CVJA, CVKB, CWZA, CYFB, CYMC, CYNB, CYP A, CYPB, CYRB, CYRC, CZPB, DJHA, CESA, DKNA, DLHB CAEA, CAEB, CAED, CAWB, CBFA, CCTA, CCZA, CCZC CDNB, CDNC, CFKA, CHHB, CHHC, CHJA, CJXB, CJXC, CJXD, CJXF, CJXG, CNCB, CNCD, CNCE, CNTC, CPMA  Porsche DKNA, DLHB, MCN.CC, MCY.NA, MCY.NB, MCY.PA  2.0 cc TFSI/TSI/ FSI  R4	Passat, Golf, Multivan, CC, Scirocco, Eos Bettle, Jetta, Sharan, Transporter Caravelle, Bora, Vento Tiguan, T-Roc, Amarok  A1, A2, A3, A4, A5, A6, A7, Q2, Q3, Q5, Q7, TT  Mecan  Leon, Altea, Alhambra, Ateca  Superb, Kadiahq, Octavia, Yeti		 <p>568 gr   Torque : 50 Nm</p>	Connecting Rod STD  Bolt - 10.9 M8x1 L: 47 mm	<b>BMY1013</b> 1 pc.24x10x4cm
 	  				

Engine Type	Models	Picture	Sizes (mm)	Products	BMY Reference
<b>14</b>	<p>Audi Audi A4, A5, A6, CZZA/B, CLZB, CZVA/B/C/D/E/F, CVUA/B/C, CUEA, CRCA, CTCB/C, CTBA/B/C/D CRTC/D/E/F CPNA/B, CCLA CNRB, CMHA CLAA/B, CJMA, CKVB/C/D, CGQB, CDUC/D, CDTA/B/C</p> <p>Porsche Panamera, Cayenne, Macan</p> <p>Volkswagen Touareg</p> <p>Porsche MCVA/B/C, MCTBA/B/C/D, MCRC-/A/B/C MCRNB, MCDUD</p> <p>Volkswagen CWA, CVA, CRCA, CRCD, CNRB, CJMA</p> <p>3.0 TDI</p> <p>V6</p>		<p>715 gr   Torque : 45Nm 2nd Torque Option : 35Nm +90°</p>	<p>Connecting Rod STD <b>BMY1014</b> 1 pc. 30x12x4cm</p> <p>Connecting Rod SEMI <b>BMY1014SEMI</b> 1 pc. 30x12x4cm</p> <p>Bushing Bimetal Locked-Straight <b>BMY1014B</b> 4 pcs. 10x6x4cm</p> <p>Bolt - 10.9 M8x1 L:47 mm <b>BMY1014CB</b> 8 pcs. 10x6x4cm</p> <p>Con. Rod OEM : 059198401N, 059198401H, 59AE</p>	<p>FORGE</p> <p>CRACKED</p> <p>TAPERED</p>
<b>15</b>	<p>Audi CAJA, CAKA, CCAA, CCBA, CMDA, CGWA/B/C/D, CGXA/B/C, CHMA/B, CJTB/C, CJWB/C/E, CMUA, CNA, CREA/C/D, CREG/H, CTDA, CTTA, CTUA/B/C/D, CTVA, CTXA, CTWA/B, CWGD, DLZA CZSA/E, DCBD/E</p> <p>Bentayga</p> <p>Cayenne, Panamera</p> <p>Touareg</p> <p>Bentley, Porsche DCBE, DLZB, MCX.TA, MDC.BE</p> <p>Volkswagen CGEA, CGFA, CJTA, CPFA, CYJA, DCBE</p> <p>3.0 TFSI</p> <p>V6</p>		<p>580 gr   Torque : 45 Nm</p>	<p>Connecting Rod STD <b>BMY1015</b> 1 pc. 24x10x4cm</p> <p>Connecting Rod SEMI <b>BMY1015SEMI</b> 1 pc. 24x10x4cm</p> <p>Bushing Bimetal Locked-Straight <b>BMY1015B</b> 4 pcs. 10x6x4cm</p> <p>Bolt - 10.9 M8x1 L:47 mm</p> <p>Con. Rod OEM : 06E198401J, 06E198401D, 06E198401E</p>	<p>FORGE</p> <p>CRACKED</p> <p>TAPERED</p>

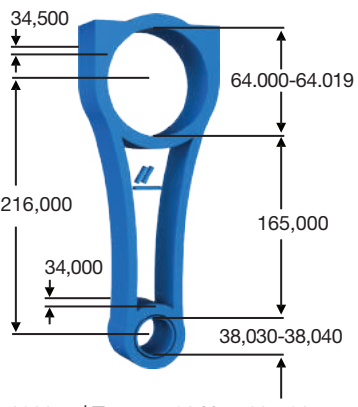
Engine Type	Models	Picture	Sizes (mm)	Products	BMY Reference
<b>1</b> Deutz BFL 1011 R4	  			Connecting Rod STD	<b>BMY0301</b> 1 pc.30x12x6cm  Con. Rod OEM : 0428 6691
<b>2</b> Deutz BFL 1011/F R4	  			Connecting Rod STD	<b>BMY0302</b> 1 pc.30x12x6cm  Con. Rod OEM : 0427 2007, 0417 8999
<b>3</b> Deutz TD/TCD 3.6 L4 1011N, TD2011 Euro III, IV, V R4	  			Connecting Rod STD	<b>BMY0303</b> 1 pc.30x12x6cm  Con. Rod OEM : 0428 6940
<b>4</b> Deutz/KHD, Deutz Fahr, Fendt BF 6L 912, F 2L 912, F 3L 912 D, F 3L 912 W, F 4L 912D/W, F 5L 912 D, F 6L 912 D/W	  			Connecting Rod STD	<b>BMY0304</b> 1 pc. 24x10x4cm  Con. Rod OEM : 0415 0450, 0337 1614

# BMY<sup>®</sup> CONNECTING ROD

Manufacturer: Basaran Motor Ltd. Şti.  
Marketing Co: BMY İç ve Dış Tic. Ltd. Şti.

Address: Büyükkayacık OSB Mah. 15. Sk.  
No: 3 42160 Konya, Turkey

Tel : +90 332 251 55 65  
Fax: +90 332 251 24 26  
Web: www.bmy.com.tr

General Information & Sales: bmy@bmy.com.tr

Latin America Sales: latin@bmy.com.tr

Eurasia Sales: eurasia@bmy.com.tr  
M: +90 552 312 05 42

**Domestic Sales - Support**  
Inlandsverkäufe - Förderung  
Yurtiçi Satış - Destek:  
satisdestek@bmy.com.tr  
M: +90 506 487 28 51

