



PRODUCT CATALOGUE

2021

BM Y [®]
CONNECTING
ROD

CONNECTING ROD & COMPONENTS
PLEUELSTANGE & KOMPONENTEN
PISTON KOLU & EKİPMANLARI

**HELLO | HALLO | MERHABA**

1971

The foundations of our company were laid by Salih Öztaş with the opening of a 35m² motor rectification shop.



1979

We moved to an 300 m² area in Konya Karatay industrial site.

1994

With Crankshaft welding, we have started our complete crankshaft revision activities and we have incorporated Surface Roughness and Hardness Testing, Electromagnetic Crankshaft Inspection systems into our company.



In this catalogue,

In this catalogue we offer you the products of BMY which is the best aftermarket connecting rod manufacturer. Having proven itself in the international automotive spare parts market, especially in the production of connecting rods of light commercial and passenger vehicles, BMY is a supplier to the world's leading automotive companies. Quality products, reassuring sales and after-sales services, product variety, fast shipping, 100,000 km engine warranty are among the most important reasons for choosing BMY products. Today, as BMY, we are experiencing the happiness of this trust and preference. We continue to grow by sharing our happiness, trust and earnings with our suppliers, customers and employees. You can always contact BMY about our company and our products in this catalogue. We would like to express our deepest gratitude to you for your interest. Together to many great happiness and success ...

BMY Family

In diesem Katalog,

In diesem Katalog bieten wir Ihnen die Produkte von BMY an, dem besten Hersteller von Pleuelstangen für den Ersatzteilmarkt. BMY hat sich auf dem internationalen Markt für Kfz-Ersatzteile, insbesondere bei der Herstellung von Pleueln für leichte Nutz- und Personenkraftwagen, bewährt und ist Zulieferer der weltweit führenden Automobilunternehmen. Qualitätsprodukte, beruhigende Verkaufs- und Kundendienstleistungen, Produktvielfalt, schneller Versand und 100.000 km Motorgarantie sind die wichtigsten Gründe für die Wahl von BMY-Produkten.

1996

We started our wholesale spare parts sales activities.

2003

We moved to our new location of 2000m².

2008

We have obtained ISO 9001: 2008 Quality Certificate.

2009

We have started Connecting Rod Manufacturing.

2016

We have expanded our factory site for flexible and efficient production. Molding operations started in own factory. We have founded Quality Control Laboratory.

2017

Hot forging operations started in-house.



2018

Updated ISO 9001: 2015 Quality Certificate. We have started to apply Product Liability Insurance for all products.

2019

In order to increase our production efficiency, to use our machine, human, time and raw material resources in the most effective way and to minimize human error, we have implemented ERP (Enterprise Resource Planning) software. We chose Canias ERP which is one of the best software in its field on a global scale.

canias ERP

Heute erleben wir als BMY das Glück dieses Vertrauens und dieser Präferenz. Wir wachsen weiter, indem wir unser Glück, Vertrauen und Ergebnis mit unseren Lieferanten, Kunden und Mitarbeitern teilen. Sie können BMY jederzeit über unser Unternehmen und unsere Produkte in diesem Katalog kontaktieren. Wir möchten Ihnen unseren tiefsten Dank für Ihr Interesse aussprechen. Zusammen zu vielen großen Glück und Erfolg ...

BMY Familie

Bu Katalogda,

Size dünyanın en iyi aftermarket biyel kolu üreticisi olan BMY'nın ürünlerini sunmaktayız. Özellikle hafif ticari ve binek araçların biyel kolları üretiminde kendini uluslararası otomotiv yedek parça pazarında ispatlayan BMY, dünyanın önde gelen otomotiv firmalarına tedarikçilik yapmaktadır. Kaliteli ürünler, güven veren satış ve satış sonrası hizmetleri, ürün çeşitliliği, hızlı sevkiyatı, 100.000 km motor garantisi BMY ürünlerinin en önemli tercih sebeplerindedir. Bugün BMY olarak bu güvenin ve tercihlerin mutluluğunu yaşıyoruz. Mutluluğumuzu, güvenimizi ve kazancı tedarikçilerimizle, müşterilerimizle, çalışanlarımızla paylaşarak büyümeye devam ediyoruz. Bu katalogta bulunan ürünlerimiz ve firmamızla ilgili BMY ile her zaman iletişime geçebileceğinizi belirtmek isteriz. Göstermiş olduğunuz ilgiden dolayı en derin teşekkürlerimizi sunarız. Hep beraber nice büyük mutluluk ve başarılarla...

BMY Ailesi

BMY CONNECTING ROD

Kalite Politikamız

Ahlak ve vicdani değerler çerçevesinde, en iyi şekilde çalışarak, kalma değerli ürünler üretmek.

Ne ürettiğimizin bilinciyle, işimizi severek en iyi şekilde yapmak.

En iyi şekilde yaptığımız işlerimizle, müşterilerimizi ve ürün kullanıcılarımızı mutlu etmek.

Mutlu müşterilerimizin sayısını her geçen gün artırarak, sektöründe global bir marka haline gelmek.

Sevilen ve saygı duyulan global bir marka olarak, toplumlara rol model olmak.

Our quality policy

To produce value-added products by working in the best way within the framework of moral and conscientious values.

To do our job in the best way with the awareness of what we produce

To make our customers and product users happy with the works we do in the best way.

To become a global brand in the sector by increasing the number of our happy customers day by day.

To be a role model to societies as a loved and respected global brand.

Taahhütümüzdür

BMY yönetimi üretim tesislerinde, aşağıdaki beşeri ve fiziki unsurları sağlanmasını güvence altına almıştır.

Personeline karşı adil olmak ve ayırımı yapmamak. Kutuplaşmırmamak, etnik köken, dil, din ve oriyent ayırımı yapmamak.

Dünya ve fikir özgürlüklerine saygı duymak ve bunu garanti altına almak.

Katılımı, kapsayıcı, paylaşımcı, barışçıl olup, fırsat eşitliği sağlamak.

İş sağlığı ve güvenliği kurallarına riayet ederek, bunun uygulayıcısı ve takipçisi olmak.

Our Commitment

BMY management has ensured that the following humane and physical elements are provided in the production facilities

To be fair to their staff and not to discriminate. Not to polarize, not to discriminate based on ethnicity, language, religion and gender.

To respect and guarantee freedom of thought and opinion.

To be participatory, inclusive, sharing, peaceful and provide equal opportunity.

To be a practitioner and follower of occupational health and safety rules.

Müşterilerimiz için değer yaratmak, beklentilerine kalite ve istikrarla karşılık vermek il **önceliğimizdir**. Ürünlerimize sahip çıkmak ve satış sonrasında da müşterilerimizin yanında olmak **görevimizdir**. Ürün ve hizmetimizin kalitesi ekibimizin kalitesiyle bağlıdır. En iyi personel ve yetiştirilmiş insan gücünü istihdam etmek, insanımızın yeteneklerinden ve yaratıcılığın en üst düzeyde fayda sağlamak, verimliliklerini artırmak, gelişmelerine imkan tanımak ve dayanışmanın olduğu bir çalışma ortamı yaratmak, şirketimizin kusaksız boyu devamlılığını sağlamak için **stratejimizdir**. Tedarikçilerimizle ve müşterilerimizle, tüm insanı ve ticari ilişkilerimizde adil, iyi niyet ve anlayışla davranmak, yasalara ve ahlak kurallarına uymak vazgeçilmez **ilke**lerimizdir.

Our first **priority** is to create value for our customers and to respond to their expectations with quality and stability. It is our **duty** to stick by our products and to be with our customers after sales. The quality of our product and business starts with the quality of our team. In order to ensure the continuity of our company for generations, our **strategy** is to employ the best personnel and trained manpower, to benefit from the talents and creativity of our people at the highest level, to increase their productivity, to enable them to develop and to create a working environment with solidarity. It is our **indispensable** principle to behave fairly, in good faith and understanding in all our human affairs and commercial relations with our suppliers and customers, and to comply with the laws and ethical rules.

VIZYONUMUZ MİSYONUMUZ

İLKELERİMİZ

OUR PRINCIPLES

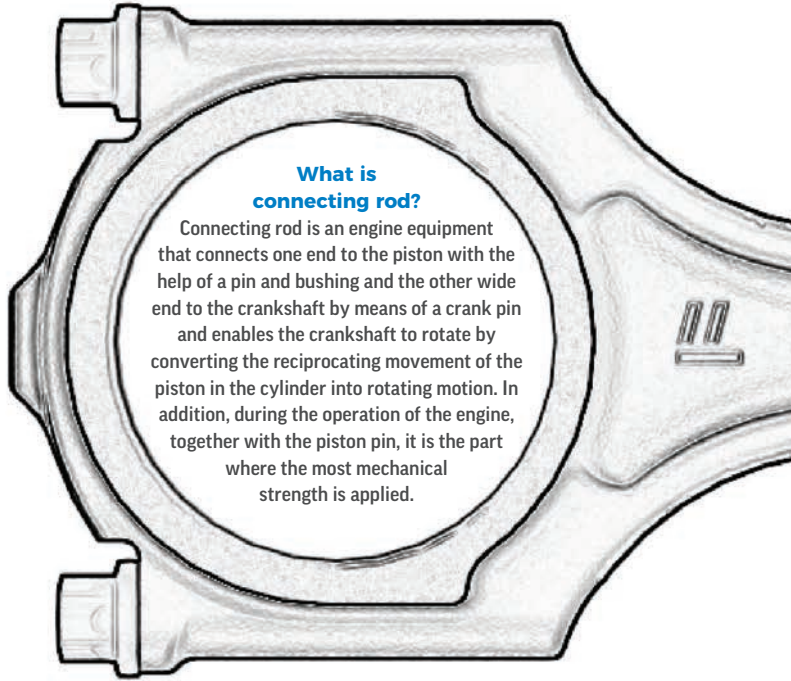

What is connecting rod?

Connecting rod is an engine equipment that connects one end to the piston with the help of a pin and bushing and the other wide end to the crankshaft by means of a crank pin and enables the crankshaft to rotate by converting the reciprocating movement of the piston in the cylinder into rotating motion. In addition, during the operation of the engine, together with the piston pin, it is the part where the most mechanical strength is applied.

Was ist Pleuelstange?

Die Pleuelstange ist eine Motorausüstung, die ein Ende mit Hilfe eines Stifts und einer Buchse mit dem Kolben und das andere breite Ende mit Hilfe eines Kurbelzapfens mit der Kurbelwelle verbindet und es der Kurbelwelle ermöglicht, sich zu drehen, indem die Hin- und Herbewegung des Kolbens umgewandelt wird der Zylinder in Drehbewegung. Darüber hinaus ist es während des Betriebs des Motors zusammen mit dem Kolbenbolzen der Teil, an dem die meiste mechanische Festigkeit angewendet wird.

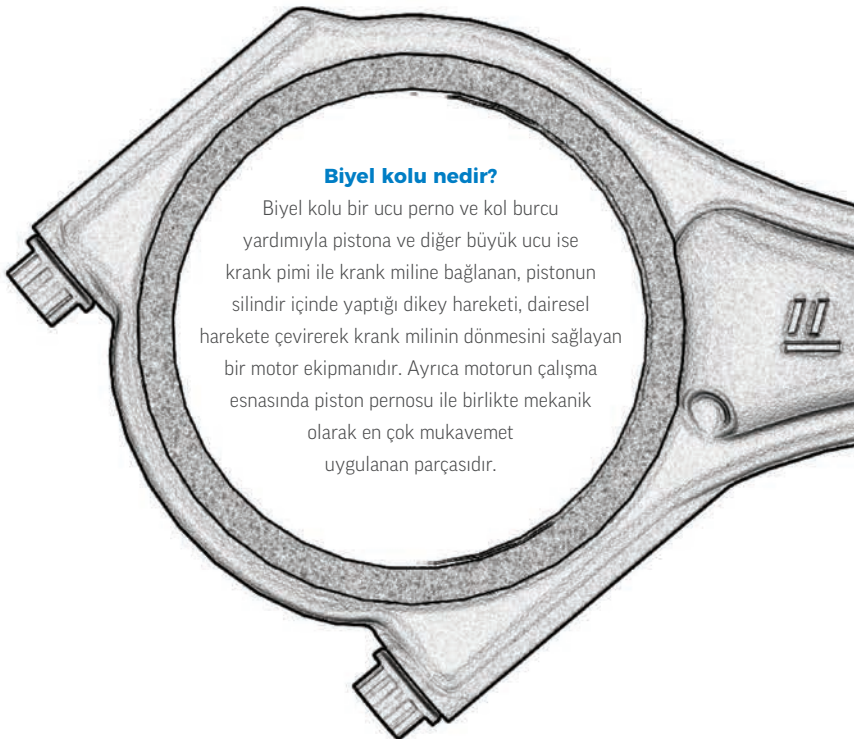

Biyel kolu nedir?

Biyel kolu bir ucu perno ve kol burcu yardımıyla pistonu ve diğer büyük ucu ise krank pimi ile krank miline bağlanan, pistonun silindiri içinde yaptığı dikey hareketi, dairesel harekete çevirerek krank milinin dönmesini sağlayan bir motor ekipmanıdır. Ayrıca motorun çalışma esnasında piston pernosu ile birlikte mekanik olarak en çok mukavemet uygulanan parçasıdır.

Did you know ?

Connecting rod is firstly used by scientist Ismail Al-Jazari in Cizre which is in the southeast of Turkey, in 1198 in order to pump water.

The connecting rod, which has been developed over time, has been used in steam locomotives and mill machines, and today it continues to exist in gasoline, diesel, hybrid and hydrogen engines.

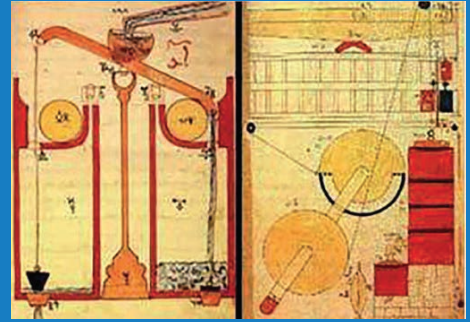

Wussten Sie schon ?

Die Pleuelstange wird erstmals 1198 vom Wissenschaftler Ismail Al-Jazari in Cizre im Südosten der Türkei verwendet, um Wasser zu pumpen. Die im Laufe der Zeit entwickelte Pleuelstange wurde in Dampflokomotiven und Mühlenmaschinen eingesetzt und ist bis heute in Benzin-, Diesel-, Hybrid- und Wasserstoffmotoren vorhanden.

Biliyor muydunuz ?

Biyel kolu ilk olarak 1198 yılında Türkiye'nin güney doğusunda bulunan Cizre'de, bilim adamı Ismail El-Cezeri tarafından su pompalamak amacıyla kullanılmıştır. Zamanla geliştirilerek buharlı lokomotiflerde, değirmen makinalarında kullanıldıktan sonra günümüzde, benzinli, dizel, hybrid ve hidrojenli motorlarda varlığını sürdürmektedir.



BMV products are manufactured with hot forging method.

BMV-Produkte werden im Heischmiedeverfahren hergestellt.

BMV rnleri sıcak dvme yntemiyle retilmektedir.



BMV uses rolled-locked type bushings which are made of steel outside and bronze inside. The high quality of the bushes prevents them from rotating in their bearings.

BMV verwendet gewalzte Buchsen, die auen aus Stahl und innen aus Bronze bestehen. Die hohe Qualitt der Buchsen verhindert, dass sie sich in ihren Lagern drehen.

BMV, Dıı elik, ii sarı malzemenen kıvrıma ve kilitli tip olarak retilen kol burlarını kullanmaktadır. Yksek kaliteli kol burlarıyla, kol burcunun, yuvasında dnmesi engelenmi olur.



The cold forged bolts are of 10.9 and the hot forged bolts are of 12.9 quality.

Die kaltgeschmiedeten Schrauben haben eine Qualitt von 10,9 und die heigeschmiedeten Schrauben eine Qualitt von 12,9.

Souk dvme yntemiyle retilen cıvatalar 10,9, sıcak dvme cıvatalar 12,9 kalitesindedir.

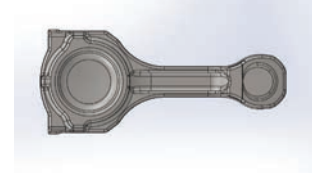

The weight is adjusted while still in the moulding phase with the CAD program, and the tolerances are kept inside minimum values range.

Das Gewicht wird noch in der Formphase mit dem CAD-Programm eingestellt und die Toleranzen werden innerhalb des Mindestwertbereichs gehalten.

Aırlık henz CAD programı ile kalıplama aamasındayken ayarlanıp, toleransları minimum seviyede tutulmaktadır.

BMV has been producing with the know-how in engine technologies, which comes from experience of engine rebuilding since 1971. Today, it continues to produce with the steel forging method with brand new and state-of-the-art production lines.

BMV produziert seit 1971 mit dem Know-how in Motorentechnologien, basierend auf Erfahrungen mit Motorreparaturen. Heute produziert BMV weiterhin im Stahlschmiedeverfahren mit brandneuen und hochmodernen Produktionslinien.

BMV Motor rektifiyecilikten gelen 1971 yılından beri motor teknolojilerinde sahip olduu know-how ile retimlerini gerekletirmektedir. Bugn yepyeni ve son teknoloji retim hatlarıyla, elik dvme yntemiyle retmeye devam ediyor.

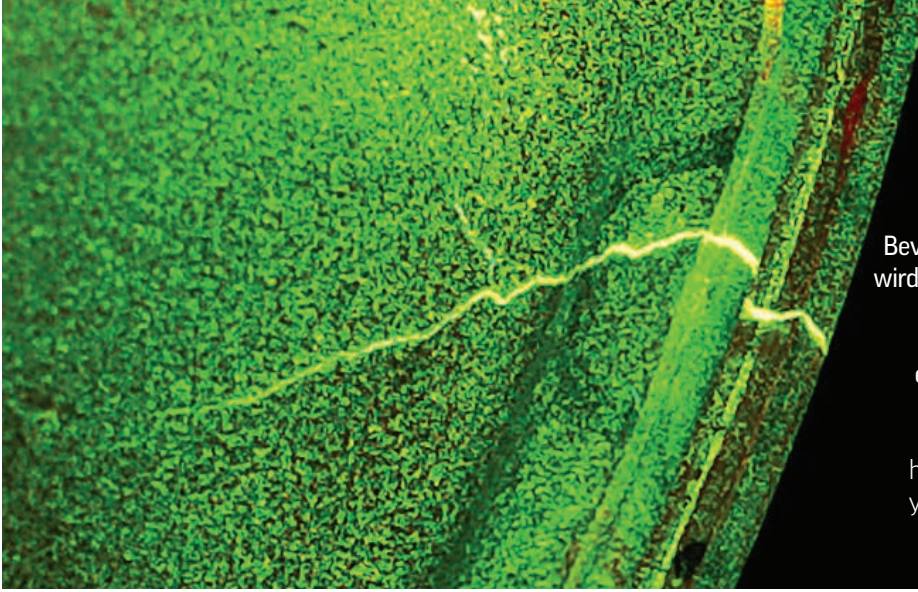

Before our connecting rods are forged, micro fracture control is performed while they are in raw material state. After forging, it is subjected to a fracture test again.

Bevor unsere Pleuel geschmiedet werden, wird die Mikrobruchkontrolle durchgeführt, während sie sich im Rohstoffzustand befinden. Nach dem Schmieden wird es erneut einem Bruchtest unterzogen.

Biyel kollarımız henüz dövülmeden hammadde halindeyken çatlak kontrolü yapılır. Dövüldükten sonra tekrar çatlak testine tabi tutulur.



Connecting rods are individually controlled for size, hardness and surface roughness. Each connecting rod produced is given an identity number and in case of any malfunction, its feedback can be obtained easily.

Pleuelstangen werden individuell für die Größe, die Härte und Oberflächenrauigkeit gesteuert. Jede produzierte Pleuelstange erhält eine Identifikationsnummer und im Falle einer Fehlfunktion kann ihre Rückmeldung leicht eingeholt werden.

Biyel kolları tek tek ölçü, sertlik ve yüzey pürüzlülük kontrolü yapılmaktadır. Üretilen her biyel kolu kimliklendirilerek herhangi bir aksaklıkta geri dönüşümü kolayca yapılabilir.

Cracked-type connecting rods are produced to prevent wear of connecting rod-cap connection surfaces, especially in high-torque vehicles, and to be long-lasting.

Connection points between rod and cap have hundreds of surfaces. Thus, the cap and rod surfaces deteriorate less and the engine life is prolonged. As a matter of fact, the cap mouths, which were designed as flat in the past, were later produced with milling.

Finally, cracked type connecting rods have been the choice of all engine manufacturers and designers.

Gebrochene Pleuel werden hergestellt, um den Verschleiß der Pleuelkappen-Verbindungsflächen, insbesondere bei Fahrzeugen mit hohem Drehmoment, zu verhindern und um eine lange Lebensdauer zu gewährleisten.

Verbindungspunkte zwischen Stange und Kappe haben Hunderte von Oberflächen. Dadurch verschlechtern sich die Oberflächen der Kappe und der Stange weniger und die Lebensdauer des Motors wird verlängert. Tatsächlich wurden die Kappenmündungen, die in der Vergangenheit als flach ausgelegt waren, später durch Fräsen hergestellt.

Schließlich waren gerissene Pleuel die Wahl aller Motorenhersteller und -konstrukteure.

Kırma tip biyel kolları, özellikle yüksek torklu araçlarda biyel-kep bağlantı yüzeylerinin aşınmaması ve uzun ömürlü olması için üretilmektedir.

Kol ve kep arasındaki bağlantı noktaları, yüzlerce yüzeye sahiptir. Böylelikle, kep ve kol yüzeyleri daha az bozulmakta, motor ömürleri uzamaktadır. Nitekim önceleri düz olarak tasarlanan kep ağızları, sonradan frezeli olarak üretilmiştir.

En nihayetinde kırma tip biyel kolları bütün motor üretici ve tasarımcısı firmaların tercihi olmuştur.

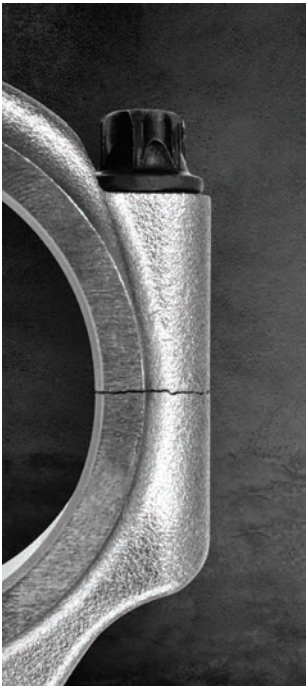



Garanti Bilgilendirme Formu

Garanti Bilgilendirme Formu **BMY** CONNECTING
ROD

BMY Türkiye Numarası: BMY-...
 Ürün Kimliği: BMY-...
 BMY Ürün Modeli (veya) Seri: ...
 Modeli Kimliği: ...
 BMY Ürün distribütörleri veya yetkili servisleri aşağıdaki gibidir:
 Garanti Ekspertizleri Garanti Ekspertizleri Ekspertizleri
 Müşteri Adı: ...
 Adres: ...
 Telefon Numarası: ...
 E-posta Adresi: ...
 Araç Tipi: Binek Araç Tuzak Kamyonet Kamyon Otobüs Diğer
 Müşteri İmzası: _____
 Tarih: .../.../...



Warranty Notice Form

Warranty Notice Form **BMY** CONNECTING
ROD

BMY Türkiye Numarası: BMY-...
 Ürün Kimliği: BMY-...
 BMY Ürün Modeli (veya) Seri: ...
 Modeli Kimliği: ...
 BMY Ürün distribütörleri veya yetkili servisleri aşağıdaki gibidir:
 Garanti Ekspertizleri Garanti Ekspertizleri Ekspertizleri
 Müşteri Adı: ...
 Adres: ...
 Telefon Numarası: ...
 E-posta Adresi: ...
 Araç Tipi: Binek Araç Tuzak Kamyonet Kamyon Otobüs Diğer
 Müşteri İmzası: _____
 Tarih: .../.../...

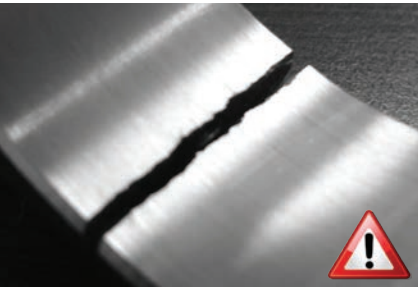
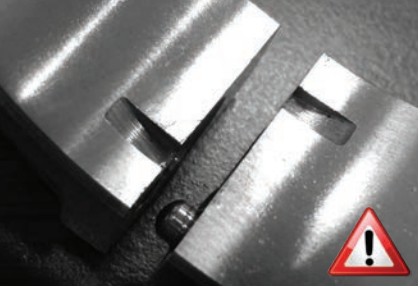
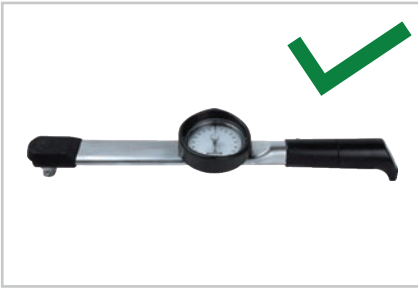
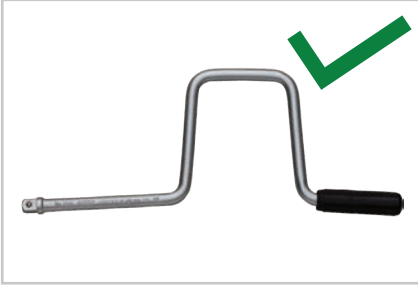

Montage Instructions

Please check the product you ordered by comparing informational labels on the box.

Although normally there is no problem with their weights, it is recommended to check their weights before assembly. For the products out of weight tolerance range, please contact BMV.

Connecting rod bolts should be torqued according to the values determined by Engine Manufacturer Company. It is recommended to oil connecting rod bolts during montage and high-pressure screwing tools must not be used.

While assembling rod bearings, attention should be paid to the lug location directions and identical numbers on the rod parts. The cracked-type rods without lug should be assembled by carefully fitting each other and by paying attention to the production numbers on each sides.

Montageanleitung

Bitte überprüfen Sie das von Ihnen bestellte Produkt, indem Sie die Informationsetiketten auf der Verpackung vergleichen. Obwohl normalerweise kein Problem mit den Gewichten besteht, wird empfohlen, die Gewichte vor dem Zusammenbau zu überprüfen.

Für Produkte außerhalb des Gewichtstoleranzbereichs wenden Sie sich bitte an BMV. Die Pleuelschrauben sollten ein Drehmoment gemäß den von der Engine Manufacturer Company festgelegten Werten aufweisen. Es wird empfohlen, die Pleuelschrauben während der Montage zu ölen, und es dürfen keine Hochdruck-Schraubwerkzeuge verwendet werden.

Bei der Montage der Pleuel-Stangenlager sollten die Richtungen der Lugposition und die identischen Nummern auf den Pleuel-Stangenteilen beachtet werden. Die gerissenen Pleuel-Stangen ohne Ansatz sollten zusammengebaut werden, indem sie sorgfältig zusammengefügt werden und die Produktionsnummern auf jeder Seite beachtet werden.

Montaj Kılavuzu

Kutu üzerindeki bilgilendirici etiketle istediğiniz ürünü karşılaştırarak kontrol ediniz.

Ürünlerde ağırlık problemi olmamasına rağmen montajdan önce ağırlık kontrolünün yapılması tavsiye edilir. Ağırlıkları toleransların dışında olan ürünler için BMV ile iletişime geçiniz.

Bağlantı saplamaları motor üretici firmanın belirlediği veya BMV Katalogundaki değerlere göre torklanmalıdır. Bağlantı saplamaları montajlanırken yağlanması tavsiye edilir ve kesinlikle yüksek hava basınçlı sıkma aletleri kullanılmamalıdır.

Kol yataklarının montajında tırnak yeri yönlerine ve kol üzerinde ki eş imalat numaralarına dikkat edilmelidir. Tırnak yeri olmayan kırma tip piston kollarında üretim numarasına dikkat edilerek, kırık yüzeyler birbirine dikkatlice geçirilerek montajlanmalıdır.

Perno ölçülerine ve temizliğine montajdan önce dikkat edilmelidir.

Engine Type	Models	Picture	Sizes (mm)	Products	BMY Reference
1					
A Iveco - Fiat F1AE	Iveco Daily Fiat Ducato UAZ Patriot			J Connecting Rod STD - Tapered	BMY1405 1 pc.30x12x6cm P
B 2.3 cc	Karsan Jest/J10			K Connecting Rod SEMI - Tapered	BMY1405SEMI 1 pc.30x12x6cm Q
C R4	E	F		L Bushing Bimetal Locked-Straight	BMY1405B 4 pcs. 10x6x4cm R
				M Bolt - 10.9 M10x1,25 L: 49	BMY1405CB 8 pcs. 10x6x4cm S
				N Con. Rod OEM :504 341 501 504 057 276	
	D				
					T

A Engine Type Motortyp Motor Tipi	K Connecting Rod SEMI - Un-bored Con. Rod Bushing Connecting Rod SEMI - Un-bohren Bushing SEMI - Kol Burcunun içi işlenmemiş
B Engine Capacity Hubraum Motor Hacmi	L Type of Bushing Art der Buchse Kol Burcunun Tipi
C Number of Cylinders - Array Anzahl der Zylinder - Array Silindir Sayısı - Dizilimi	M Sizes and Specification of Bolt Größen und Spezifikation der Schraube Cıvatanın ölçüleri - kalitesi
D Fuel Type / Vehicle Types Kraftstoff / Fahrzeugtypen Yakıt Türü / Araç Tipleri	N Cross Numbers of Products Kreuz Anzahl der Produkte Ürünlerin Eşdeğer Numuneleri
E Using Manufacture Models Fahrzeugmodelle Kullanan Araç Modelleri	O Name of Engine Manufacturer Name des Motorenherstellers Motor Üreticisi
F Picture of Con. Rod and Bolt Bild von Pleuel und Bolzen Piston Kolu ve Cıvata Resmi	P Reference of Connecting Rod In-box quantity - Box Sizes Referenz der Pleuelstange In-Box Menge - Box Größen Piston kolu Referansı Kutu içi miktarı - Kutu Ebatları
G Weight of Connecting Rod Gewicht der Pleuelstange Piston Kolu Ağırlığı	Q Reference of SEMI Connecting Rod In-box quantity - Box Sizes Referenz der SEMI Pleuelstange In-Box Menge - Box Größen SEMI Piston kolu Referansı Kutu içi miktarı - Kutu Ebatları
H Bolt Torque Bolzen-Drehmoment Cıvata Torku	R Reference of Bushing - In-box quantity - Box Sizes Referenz der Buchse - In-Box-Menge - Box Größen Kol Burcu Referansı - Kutu içi miktarı - Kutu Ebatları
I Basic Product Dimensions Produktabmessungen Ürün Ölçüleri	S Reference of Bolt - In-box quantity - Box Sizes Referenz der Schrauber - In-Box-Menge - Box Größen Cıvata Referansı - Kutu içi miktarı - Kutu Ebatları
J Connecting Rod STD - Milled Con. Rod Bushing Connecting Rod STD - Gefräste Con. Rod Bushing Connecting Rod STD - Kol Burcunun içi işlenmiş	T Structure of Connecting Rod Type of Connecting Rod Shape of Small End Struktur der Pleuelstange Art der Pleuelstange Form des kleinen Endes Piston Kolu Yapısı Piston Kolu Türü Perno Yeri Kesiti

INDEX













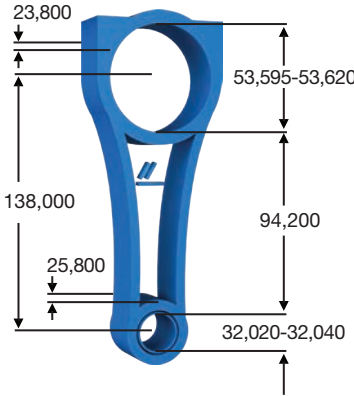



INHALTSVERZEICHNIS

ÜRETİCİ LİSTESİ

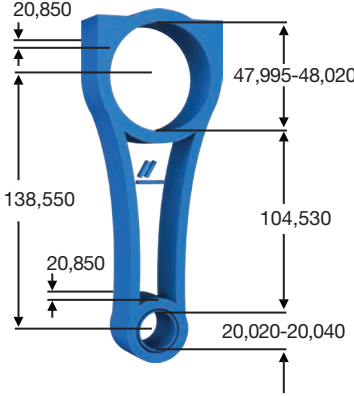
A	ALFA ROMEO	14
	AUDI	50
B	BMW	12
	BUICK	38
C	CHEVROLET	38
	CHRYSLER	16
	CITROEN	42
D	DEUTZ	55
	DS	42
F	FIAT	14
	FORD	18
G	GM	38
H	HYUNDAI	22
I	ISUZU	24
	IVECO	27
J	JAGUAR	29
	JEEP	14
K	KARSAN	Isuzu 25 Iveco 27
	KIA	22





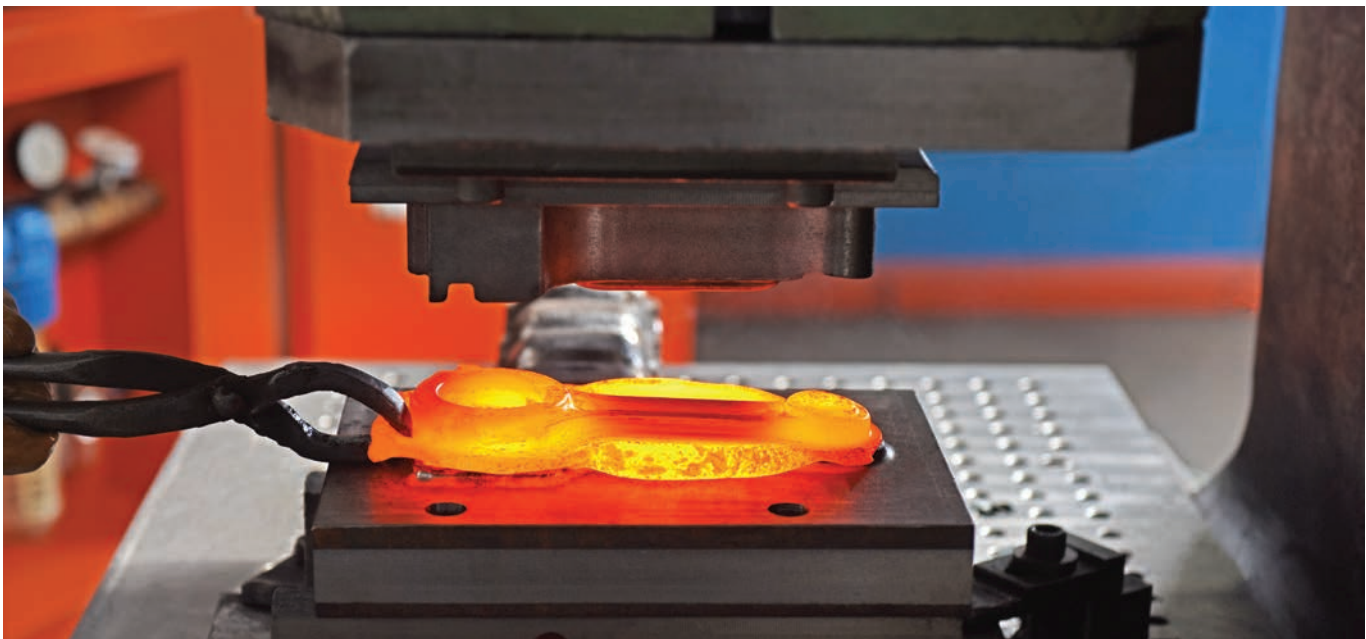

L	LANCIA	14
	LAND ROVER	29
	LOTUS	GM Opel 38
M	MAZDA	PSA 43
	MERCEDES-BENZ	30
	MINI	12
	MITSUBISHI	33
N	NISSAN-INFINITI	35
O	OPEL	38
P	PEUGEOT	42
	PORSCHE	41
R	RENAULT	46
S	SAAB	GM Opel 38
	SEAT	50
	SKODA	50
T	TATA	Fiat 14
	TOYOTA	PSA 43
V	VAUXHALL	38
	VOLVO	PSA 44 Renault 47
	VOLKSWAGEN	50
	VM	FCA 17

Engine Type	Models	Picture	Sizes (mm)	Products	BMY Reference
1					
BMW N47 D20A/B N47S N57 D30 A/B/D OL/TOP N57 306 D2/D3 N57N 306 D2/ D3/D5 B47 D20 A/B B57 D30 A/B/C	BMW 320d, 325d, 330d, 430d, 520d, 525d, 530d, 550d, 640d, 730d, X3, X4, X5, X6 E81, E82, E83, E87, E88, E90, E91, E92, E60, E61, F10, F30, F01, F02, F03, F31, F32, F33, F36, F11, F45, F20, F22, F26, F40, F56, G01, G02, G11, G15, G20, G30, G31, G32		<p>720 gr Torque : 70 Nm</p>	Connecting Rod STD Connecting Rod SEMI Bushing Bimetal Locked-Straight Bolt - 10.9 M9x1 L: 46 mm	BMY1701 1 pc.24x10x4cm BMY1701SEMI 1 pc.24x10x4cm BMY1701B 4 pcs.10x6x4cm
2					
BMW N20, B20, A/B/C/D N26/ B20 A R4 BMW N52/N B30 A/AE/B/BE/BF N53 B30 /A N55 B30 A R6	BMW 120i, 125i, 130i, 135i, 220i, 228i, 320i, 328i, 330i, 335i, 420i, 428i, 430i, 435i, 520i, 530i, 535i, 640i, 740i, X1, X3, X4, X5, X6, Z4, xDrive, sDrive, ActiveHybrid F10, F11, F15, F20, F21, F22, F23, F25, F30, F31, F34, F36, F80, E84, F87		<p>575 gr Torque : 60 Nm</p>	Connecting Rod STD Connecting Rod SEMI Bushing Bimetal Locked-Straight Bolt - 10.9 M9x1 L: 46 mm	BMY1702 1 pc.24x10x4cm BMY1702SEMI 1 pc.24x10x4cm BMY1702B 4 pc. 10x6x4cm
3					
BMW/MINI/Alpina N47 C20 A N47 D20 C B47 C20 U0 Forging No: 543 2.0 cc R4	F45, F48, F54, F30, G20 X1, 218d, 120d, 320d MINI Clubman, Countryman, Clubvan, Coupe, Cooper		<p>684 gr Torque : 60 Nm</p>	Connecting Rod STD Connecting Rod SEMI Bushing Bimetal Locked-Straight Bolt - 10.9 M9x1 L: 46 mm	BMY1703 1 pc.24x10x4cm BMY1703SEMI 1 pc.24x10x4cm BMY1703B 4 pcs.10x6x4cm

Engine Type	Models	Picture	Sizes (mm)	Products	BMY Reference
4 BMW N57 D30 S1 N57S N47 D30 C Tri-Turbo 3.0 cc	F01, F02, F10, F11, F15, F16 E70, E71 750dX, 750LdX, X5 M50dX, X6 M50dX, M550dX		 <p>710 gr Torque : 60 Nm</p>	Connecting Rod STD Bushing Bimetal Locked-Straight Bolt - 10.9 M9x1 L: 46 mm	BMY1704 1 pc.24x10x4cm BMY1701B 4 pcs. Con. Rod OEM: 11248506122
  				  	
5 BMW - MINI N13 B16 N18 B16 PSA EP6, EP6C 1.6 cc R4	BMW 114i, 116i, 118, 316i, 320i Efficient Dynamics Edition F20, F30 MINI Cooper Peugeot 207, 208, 2008, 308, 3008, 508 Citroën C4, DS3, DS4, C3		 <p>465 gr Torque : 45 Nm 2nd Torque Option : 5 Nm + 15 Nm + 130 °</p>	Connecting Rod STD Connecting Rod SEMI Bushing Bimetal Locked-Straight Bolt - 10.9 M7x1 L: 38 mm	BMY0808 1 pc.24x10x4cm BMY0808SEMI 1 pc.24x10x4cm BMY0808B 4 pcs.10x6x4cm BMY0806CB 8 pcs.10x6x4cm Con. Rod OEM 11247621253 BMW 0603 E0 PSA
  				  	

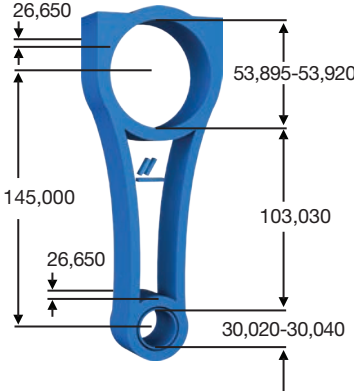
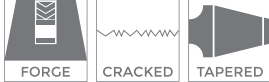

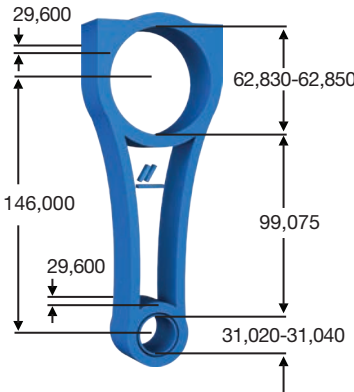
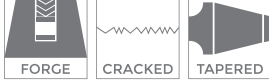

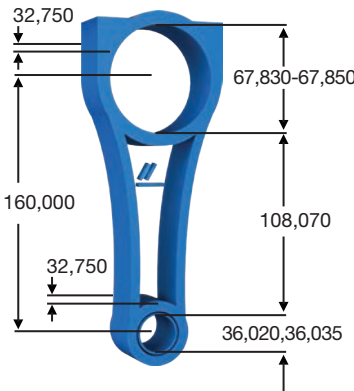
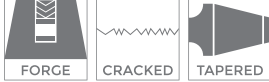







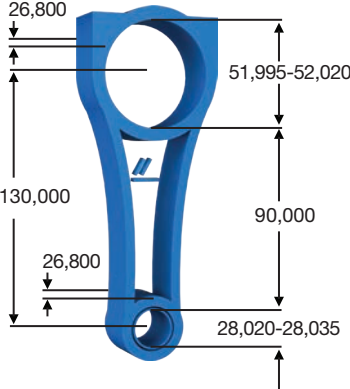







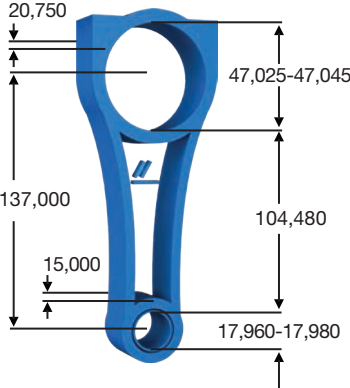

Engine Type	Models	Picture	Sizes (mm)	Products	BMY Reference	
1						
Fiat 1.3 JTD 169 A1, 169 A5, 188 A8, 188 A9. 199 A1, 199 A2, 199 A3, 199 A9, 199 B1 Euro 5, 199 B2 Euro 5, 199 B4, 223 A9, 225 A2, 263 A2 Euro 5, 263 A6 312 A8.000 Euro 6, 312 B1, 312 B2 Euro 6, 312 B5, 330 A1, 55266963, 55283775, 955 B2 1.3 cc R4	Fiat Albea, Doblò, Fiorino, Grande Punto, Linea, 500, Palio, Panda, Punto Alfa Romeo, MiTo Lancia Musa, Ypsilon Suzuki Swift, SX4, Splach TATA Indica Vista, Manza		 450 gr Torque : 45 Nm 2nd Torque Option : 20 Nm + 40 °	Connecting Rod STD Connecting Rod SEMI Bushing Bimetal Locked-Straight Bolt - 10.9 M8x1 L: 38 mm Con. Rod OEM : 735 012 29, 552 086 24	BM1401 1 pc.24x10x4cm BM1401SEMI 1 pc.24x10x4cm BM1401B 4 pcs.10x6x4cm BM1401CB 8 pcs.10x6x4cm	
2						
Fiat 1.9 D JTD 182.B9, 188 A2, 939 A2, 192.A5, 192 B1, 932 A2, 937 A1, 937 A2, 937 A3, 937 A4, 937 A5, 937 A6, 937 A7, 937 A8, 939 A1, 939 A2, 939 A7, 939 A8, AR 32302 AR 37101 Opel Z19DT/H 1.9 cc R4	Alfa Romeo 146,147,159,GT Cadillac BLS Fiat Doblo, Bravo, Punto Fiat Croma, Marea, Stilo Lancia Delta, Lybra, Musa Opel Signum, Vectra C, Zafira B Saab 9-3, 9-5, Suzuki SX4		 760 gr Torque : 60 Nm	Connecting Rod STD Connecting Rod SEMI Bushing Bimetal Locked-Straight Bolt - 10.9 M9x1 L: 46 mm Con. Rod OEM : 467 689 51	BM1402 1 pc.24x10x4cm BM1402SEMI 1 pc.24x10x4cm BM1402B 4 pcs.10x6x4cm	
3						
Fiat 1.6 JTD 198 A2, 198 A3, 198 A6, 199 B5, 263 A4, 940 A3, 263 A3 Euro 5, 263 A7/A8/A9 350 A2/A3, 955 A3, 844 A3, 944 A3, 955 A4 1.6 cc R4	Alfa Romeo Mito, Giulietta Fiat 500L, Bravo, Doblò, Fiat Grande, Punto, Idea, Fiat Egea, Tipo, Fiat Linea Jeep Renegade Lancia Delta, Musa Opel Combo D Suzuki Vitara, SX4 S-Cross		 645 gr Torque : 60 Nm	Connecting Rod STD Connecting Rod SEMI Bushing Bimetal Locked-Straight Bolt - 10.9 M9x1 L: 46 mm Con. Rod OEM : 552 288 71	BM1403 1 pc.24x10x4cm BM1403SEMI 1 pc.24x10x4cm BM1403B 4 pcs.10x6x4cm	



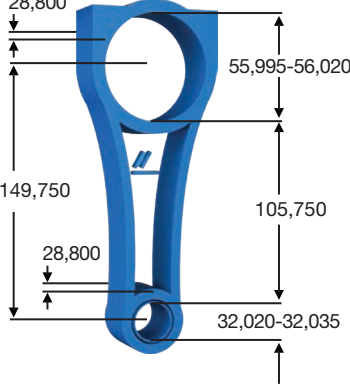







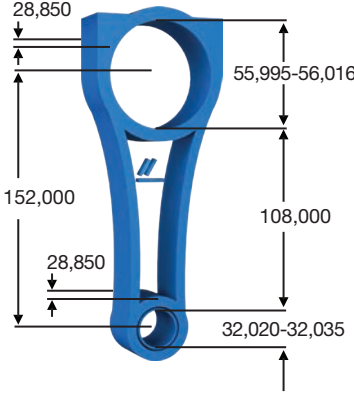







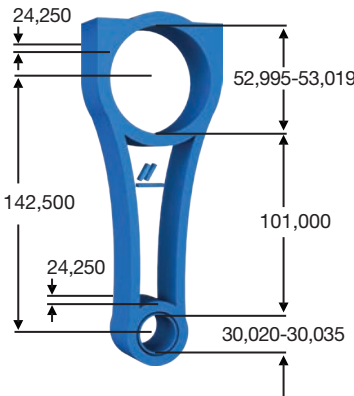











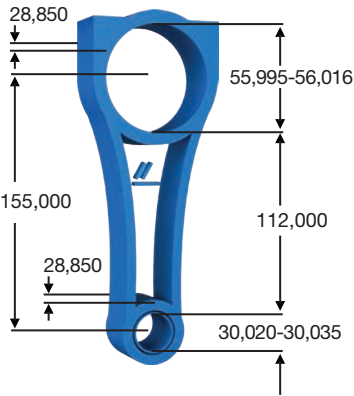

Engine Type	Models	Picture	Sizes (mm)	Products	BMY Reference
<p>4</p> <p>Fiat 2.0 JTD 263A1 D20AA B182 B900, 939 B3, 939 B4, 940 A4, 940 A7 Euro 5, 940 A8 Euro 5, 198 A5, 198 A5, 250 A1 Euro 5, 250 A2, 263 A1 Euro 5, 844 A2, 939 B5, 198 A5, 844 A2</p> <p>Opel/Vauxhall A20DTC, A20DTH, A20DTJ, A20DTL, Y20DTJ, Z20DTJ</p> <p>2.0 cc</p> <p>R4</p> 	<p>Fiat Freemont, Doblo, Bravo Lancia/Chrysler Delta</p> <p>Alfa Romeo Brera, Spider, 159, Giulietta</p> <p>Opel Insignia, Astra</p>		 <p>26,650 53,895-53,920 145,000 103,030 26,650 30,020-30,040</p> <p>740 gr Torque : 60 Nm 2nd Torque Option : 25 Nm + 60 °</p>	<p>Connecting Rod STD BMY1404 1 pc.24x10x4cm</p> <p>Connecting Rod SEMI BMY1404SEMI 1 pc.24x10x4cm</p> <p>Bushing Bimetal Locked-Straight BMY1504B 4 pcs.10x6x4cm</p> <p>Bolt - 10.9 M9x1 L: 46 mm BMY0805B 8 pcs.10x6x4cm</p> <p>Con. Rod OEM: 55198189 With Bearing Lug (for without Lug BMY1504)</p> 	
<p>5</p> <p>Fiat - Iveco 2.3 JTD F1AE</p> <p>2.3 cc</p> <p>R4</p> 	<p>Fiat Ducato</p> <p>Iveco Daily</p> <p>UAZ Patriot</p> <p>Karsan Jest/J10</p>		 <p>29,600 62,830-62,850 146,000 99,075 29,600 31,020-31,040</p> <p>1140 gr Torque : 80 Nm 2nd Torque Option : 40 Nm + 60 °</p>	<p>Connecting Rod STD BMY1405 1 pc.30x12x6cm</p> <p>Connecting Rod SEMI BMY1405SEMI 1 pc.30x12x6cm</p> <p>Bushing Bimetal Locked-Straight BMY1405B 4 pcs.10x6x4cm</p> <p>Bolt - 10.9 M10x1,25 L: 49 BMY1405CB 8 pcs.10x6x4cm</p> <p>Con. Rod OEM : 504 341 501 504 057 276</p> 	
<p>6</p> <p>Fiat - Iveco 3.0 JTD F1CE</p> <p>Mitsubishi 4P10-7AT/T2/T4/T6</p> <p>3.0 cc</p> <p>R4</p> 	<p>Fiat Ducato Iveco Daily, Massif</p> <p>Citroen Jumper</p> <p>Mitsubishi Fuso Canter 8B/9BL</p>		 <p>32,750 67,830-67,850 160,000 108,070 32,750 36,020,36,035</p> <p>1340 gr Torque : 80 Nm</p>	<p>Connecting Rod STD BMY1406 1 pc.30x12x6cm</p> <p>Connecting Rod SEMI BMY1406SEMI 1 pc.30x12x6cm</p> <p>Bushing Bimetal Locked-Straight BMY1406B 4 pcs.10x6x4cm</p> <p>Bolt - 10.9 M10x1,25 L:49 mm</p> <p>Con. Rod OEM : 504 341 496</p> 	

Engine Type	Models	Picture	Sizes (mm)	Products	BMY Reference
<p>7</p> <p>Fiat-Iveco F1AF-F1AG</p> <p>2.3 cc</p> <p>R4</p> <p>Euro 6</p>	<p>Fiat Ducato, Iveco Daily</p>		<p>985 gr Torque : 60 Nm</p>	<p>Connecting Rod STD BMY1407 1 pc.30x12x6cm</p> <p>Connecting Rod SEMI BMY1407SEMI 1 pc.30x12x6cm</p> <p>Bushing Bimetal Locked-Straight BMY1407B 4 pcs.10x6x4cm</p> <p>Bolt - 10.9 M9x1 L:46 mm BMY0805CB 8 pcs.10x6x4cm</p> <p>Con. Rod OEM :5801841535, 5801842210, 5802116073</p>	<p>Icons: Truck, Van, Fuel pump</p> <p>Icons: FORCE, CRACKED, TAPERED</p>
<p>8</p> <p>Fiat/Alfa Romeo/ Dodge 169.A3, 192.B2, 198.A1, 198.A4, 198.A7, 199.A6, 199.A7, 199.A8, 312.A1, 843 A1, 350 A1, 940.B7, 955.A2, 955.A6, 955.A8, 955.A9, 178.F3, 310.A2, EAF 55263623, 55263624</p> <p>1.4 cc</p> <p>R4</p>	<p>Fiat Punto, 500, 500C, 500L, 500X, Doblo, Tipo, Ideo, Stilo, Egea, 124 Spider, Brava</p> <p>Alfa Romeo Mito, Giulietta</p> <p>Dodge Dart</p>		<p>408 gr Torque : 45 Nm 2nd Torque Option : 20 Nm + 40 °</p>	<p>Connecting Rod STD - Tapered BMY1408 1 pc.24x10x4cm</p> <p>Connecting Rod SEMI - Tapered BMY1408SEMI 1 pc.24x10x4cm</p> <p>Bushing Bimetal Locked-Straight BMY1408B 4 pcs.10x6x4cm</p> <p>Bolt - 10.9 M8x1 L: 38 mm</p> <p>Con. Rod OEM : 46743870, 46740345</p>	<p>Icons: Car, SUV, Fuel pump</p> <p>Icons: FORCE, CRACKED, TAPERED</p>
<p>9</p> <p>VM Motori A630 DOHC, A630HP, L630</p> <p>Chrysler/Jeep/ Lancia EXF, EXL, EXN, M664 CRD/TD</p> <p>Maserati A630HP, M15746D</p> <p>V6 3.0 (2987) cc</p>	<p>Jeep Grand Cherokee IV (WK, WK2), Commander</p> <p>Chrysler 300</p> <p>Maserati Ghibli III, Quattroporte VI, Levante</p> <p>Lancia Thema</p> <p>Ram 1500</p>		<p>720 gr Torque : 70 Nm</p>	<p>Connecting Rod STD BMY1409 1 pc.30x12x6cm</p> <p>Connecting Rod SEMI BMY1409SEMI 1 pc.30x12x6cm</p> <p>Bushing Bimetal Locked-Straight BMY1409B 3 pcs.10x6x4cm</p> <p>Bolt - 10.9 M9x1 L: 50 mm BMY1409CB 12 pcs.10x6x4cm</p> <p>Con. Rod OEM : 681 472 33AA</p>	<p>Icons: Car, SUV, Fuel pump</p> <p>Icons: FORCE, CRACKED, TAPERED</p>







Engine Type	Models	Picture	Sizes (mm)	Products	BMY Reference
10 Fiat Sofim 8140/ S8U,89U 2.5 cc R4	Fiat Ducato, Cromia Peugeot Boxer Renault Master, Trafic Lancia Thema		<p>1320gr Torque : 80 Nm</p>	Connecting Rod STD Connecting Rod SEMI Bushing Bimetal Locked-Straight Bolt - 10.9 M10x1,25 L: 58 mm Con. Rod OEM : 500 352 497	BMY0802 1 pc.24x10x4cm BMY0802SEMI 1 pc.24x10x4cm BMY0803B 4 pcs.10x6x4cm
11 Fiat Sofim 8140/ S8W/S9W 2.8 cc R4	Fiat Ducato Iveco Daily Renault Master, Mascott Opel Movano Citroën Jumper Peugeot Boxer		<p>720 gr Torque : 70 Nm</p>	Connecting Rod STD Connecting Rod SEMI Bushing Bimetal Locked-Straight Bolt - 10.9 M10x1,25 L: 58 mm Con. Rod OEM : 7473171	BMY0803 1 pc.24x10x4cm BMY0803SEMI 1 pc.24x10x4cm BMY0803B 4 pcs.10x6x4cm

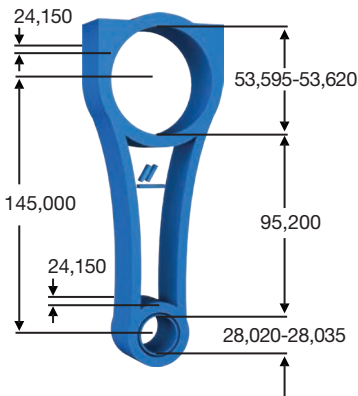

Engine Type	Models	Picture	Sizes (mm)	Products	BMY Reference
1 Ford HCPA, HCPB, P9PA, P9PC, P9PD, R3PA 90ps RWPD 110ps 1.8 cc R4	Ford Connect, Mondeo		 <p>695 gr Torque : 60 Nm 2nd Torque Option : 30 Nm+100 °</p>	Connecting Rod STD Connecting Rod SEMI Bushing Bimetal Locked-Straight Bolt - 10.9 M9x1 L:46 mm	BMY1101 1 pc.24x10x4cm BMY1101SEMI 1 pc.24x10x4cm BMY1101B 4 pcs.10x6x4cm BMY0805CB 8 pcs.10x6x4cm Con. Rod OEM : 1S4Q 6200 BD (FINIS: 1487468)
  	  				
2 Ford FYJA FYJB 1.6 cc FYDA, FYDB, FYDC, FYDD, FYDH, ZETEC R4	Ford Focus Mondeo C-Max Fusion Mazda 2		 <p>400 gr Torque : 50 Nm 2nd Torque Option : 15 Nm + 90 °</p>	Connecting Rod STD Bolt - 10.9 M8x1 L: 38 mm	BMY1102 1 pc.24x10x4cm BMY0806CB 2 pcs.10x6x4cm Con. Rod OEM : 98MM 6200 AA (FINIS: 1674827)
 	  				
3 Ford V184 D2FA H9FA H9FB JXFA 2.4 cc R4	Ford Transit V184		 <p>950 gr Torque : 80 Nm</p>	Connecting Rod STD Connecting Rod SEMI Bushing Bimetal Locked-Straight Bolt - 10.9 M10 x1,25 L:49	BMY1103 1 pc.24x10x4cm BMY1103SEMI 1 pc.24x10x4cm BMY1103B 4 pcs.10x6x4cm Con. Rod OEM : 5C10 6200 AA (FINIS: 1406170) H Degree
  	  				



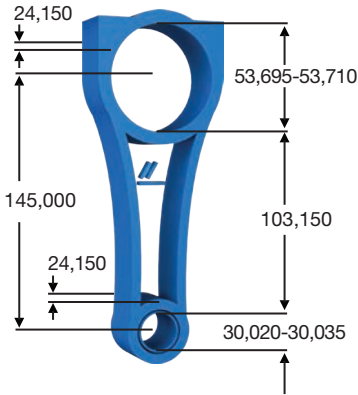

Engine Type	Models	Picture	Sizes (mm)	Products	BMY Reference
4 Ford ENSA, SAFA, SAFB, SA2R, SA2S, SA2W / 4x4 200ps 3.2 cc R5	Ford Ranger, Transit		 <p>1110 gr Torque : 80 Nm</p>	Connecting Rod STD - Tapered Connecting Rod SEMI - Tapered Bushing Bimetal Locked-Straight Bolt - 10.9 M10 x1,25 L:49 Con. Rod OEM : 7C16 6200 BAB, 7C18 6200 BAA	BMY1105 1 pc.24x10x4cm BMY1105SEMI 1 pc.24x10x4cm BMY1103B 4 pcs.10x6x4cm
   				  	
5 Ford BCCC, BJFA/B, BKFA/B, BKRA, BLFA/B, BLHA, BLRA, YLCB, YLDA, YLF6, YLFA/B, YLFS, YMCB, YMF6, YMFA/B, YMFS, YMHA, YMRA, YMR6, YNCA, YNF6, YNFA/B, YNFS, YNRA 4x2, 4x4 FWD, RWD EcoBlue, EcoBlue BiTurbo 2.0 cc - R4 Euro 6	S-Max, Galaxy, Transit Custom, Tourneo Custom V362/V363, Panther C Ranger		 <p>715 gr Torque : 60 Nm</p>	Connecting Rod STD Connecting Rod SEMI Bushing Bimetal Locked-Straight Bolt - 10.9 M9x1 L:46 mm	BMY1106 1 pc. 24x10x4cm BMY1106SEMI 1 pc. 24x10x4cm BMY1106B 4 pcs.10x6x4cm BMY0805CB 8 pcs.10x6x4cm
   				  	
				  	
6 Ford CVRA, CVRB, CVRC 155ps, CYFA, CYFB, CYFC, CYRA, CYRB 125ps, DRFA, DRFB, DRFC, DRFF, DRFG, DRF5, 100ps PGFA, PGFB, UHFA, UHFB, UHFC 140ps 2.2 cc R4	Ford Transit, Mondeo Peugeot Boxer Fiat Ducato Citroen Jumper		 <p>882 gr Torque : 60 Nm 2nd Torque Option : 30 Nm+100 °</p>	Connecting Rod STD Connecting Rod SEMI Bushing Bimetal Locked-Straight Bolt - 10.9 M9x1 L:46 mm	BMY0804 1 pc.24x10x4cm BMY0804SEMI 1 pc.24x10x4cm BMY0804B 4 pcs. 10x6x4cm BMY0805CB 8 pcs. 10x6x4cm
  				  	
				  	
				  	

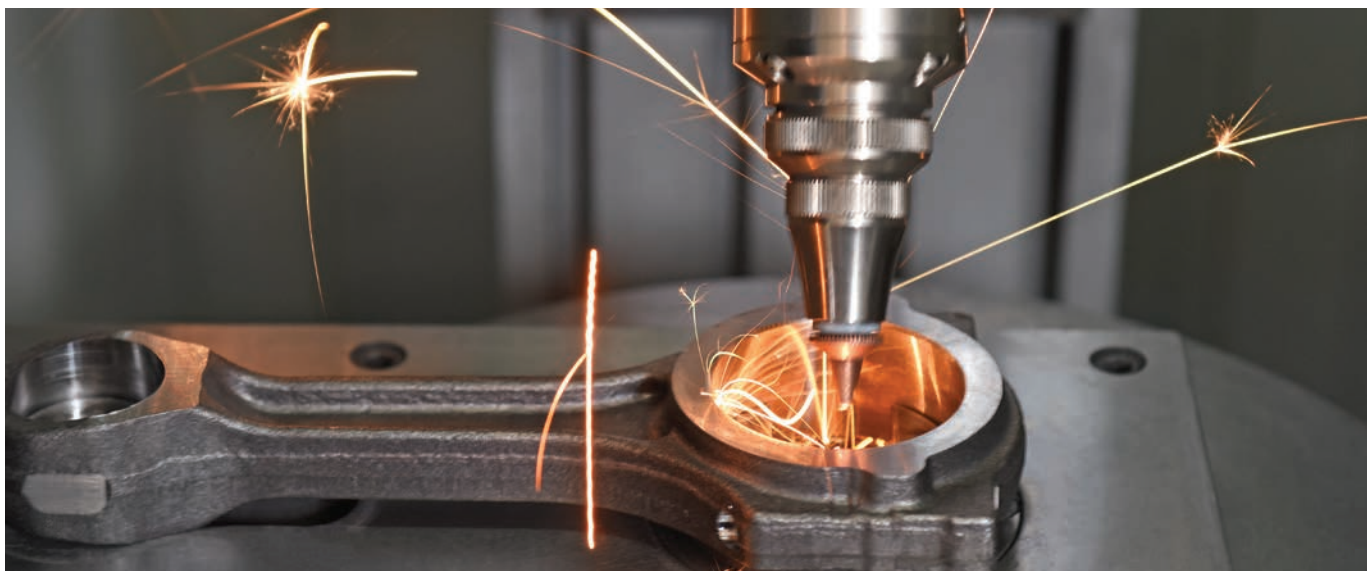
Engine Type	Models	Picture	Sizes (mm)	Products	BMY Reference
7 Ford PGFA, PGFB 140ps P8FA, P8FB 85ps QWFA 130ps QVFA 110ps 2.2 cc R4	Ford Transit, Mondeo Peugeot Boxer Fiat Ducato Citroen Jumper		<p>873 gr Torque : 60 Nm 2nd Torque Option : 30 Nm+100 °</p>	Connecting Rod STD Connecting Rod SEMI Bushing Bimetal Locked-Straight Bolt - 10.9 M9x1 L:46 mm	BMY0805 1 pc.24x10x4cm BMY0805SEMI 1 pc.24x10x4cm BMY0804B 4 pcs.10x6x4cm BMY0805CB 8 pcs.10x6x4cm Con. Rod OEM : 1S7Q 6200 CBA FIN: 1614885, 137616, 1377618, 137620, 1548564
8 Ford DLD-414 1.4 cc R4	Ford Fiesta, Fusion Peugeot 206, 207, 1007 Citroen C1, C2, C3, Xsara Mazda 2 Suzuki Liana Toyota Aygo		<p>500 gr Torque : 45 Nm 2nd Torque Option : 5 Nm + 10 Nm + 130 °</p>	Connecting Rod STD Connecting Rod SEMI Bushing Bimetal Locked-Straight Bolt - 10.9 M7x1 L: 38 mm	BMY0806 1 pc.24x10x4cm BMY0806SEMI 1 pc.24x10x4cm BMY0806B 4 pcs.10x6x4cm BMY0806CB 8 pcs.10x6x4cm Con. Rod OEM : 7S6Q 6200 AC FIN: 1509473
9 Ford DLD-416 Ford AEDA, UGJA, UGJC 1.5 - 1.6 cc R4	Ford C-Max, Focus, Fiesta Peugeot 207, 307, 308, 407, Partner, 508 Citroen C3, C4, Berlingo MINI Cooper D Mazda 2, 3 Volvo C30, S40, V50/60, S60 Suzuki SX4		<p>600 gr Torque : 45 Nm 2nd Torque Option : 5 Nm + 10 Nm + 130 °</p>	Connecting Rod STD Connecting Rod SEMI Bushing Bimetal Locked-Straight Bolt - 10.9 M7x1 L: 38 mm	BMY0807 1 pc.24x10x4cm BMY0807SEMI 1 pc.24x10x4cm BMY0807B 4 pcs.10x6x4cm BMY0806CB 8 pcs.10x6x4cm Con. Rod OEM : 7M5Q 6200 AD/AE FINIS: 1569495





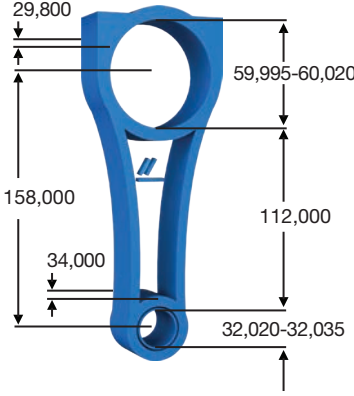
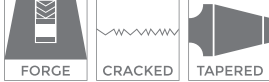

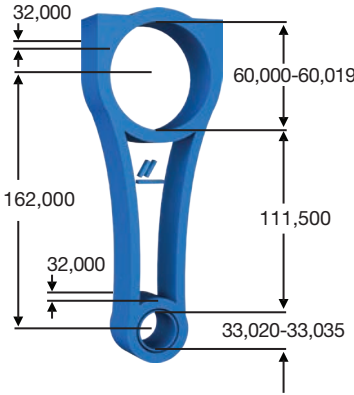
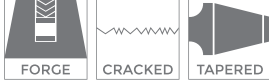



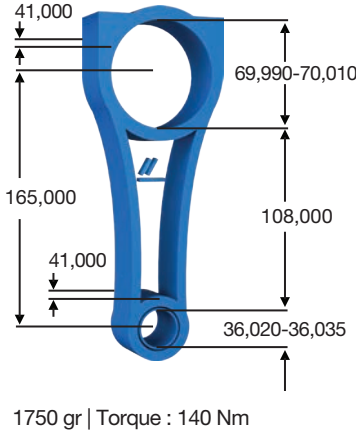







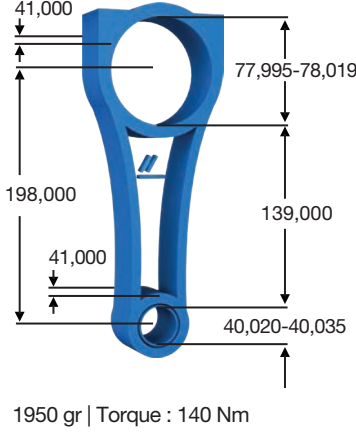





Engine Type	Models	Picture	Sizes (mm)	Products	BMY Reference
10 Ford Duratorq TDCI AZBA/ AZBC/AZWA/ AZWC/G6DA/ G6DD/G6DE/ G6DG/IXDA/ KLBA/LPBA/ QXBA/QXWB/ QXWC/UFBA 2.0 cc R4	Ford Focus, C-Max, Focus, S-Max, Galaxy, Mondeo, Kuga Peugeot Partner, 307, 407, 607, 807, 308, 508 Volvo C30, C70, S40, V50, S80, V70		 <p>780 gr Torque : 60 Nm</p>	Connecting Rod STD Connecting Rod SEMI Bushing Bimetal Locked-Straight Bolt - 10.9 M9x1 L:56 mm Con. Rod OEM : 0603 90 0603 A6 3M5Q 6200 BC	BMY0810 1 pc.24x10x4cm BMY0810SEMI 1 pc.24x10x4cm BMY0810B 4 pcs.10x6x4cm
					
11 Ford - Peugeot DW10CTED4, DW10FUD RHH, RHE, RH02 2.0 cc R4	Peugeot 308, 407, 508, 3008, 5008, RCZ, Partner Citroen C4, C5, DS4, DS5, Berlingo, Jumpy, Xsara Ford Focus, CMax, Transit		 <p>790 gr Torque : 60 Nm</p>	Connecting Rod STD Connecting Rod SEMI Bushing Bimetal Locked-Straight Bolt - 10.9 M9x1 L:46 mm Con. Rod OEM : 0603 C5 1613238180, 9M5Q 6200 AC, 1406651180, 1606651180	BMY0811 1 pc.24x10x4cm BMY0811SEMI 1 pc.24x10x4cm BMY0811B 4 pcs.10x6x4cm
					

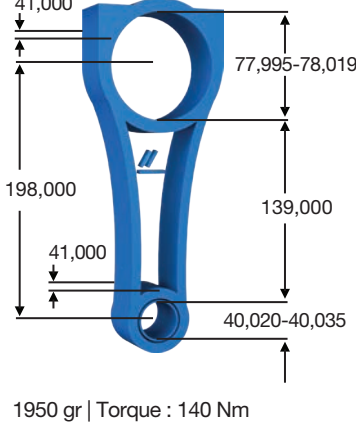

Engine Type	Models	Picture	Sizes (mm)	Products	BMY Reference
1 Hyundai - Kia D4FA/B D3FA 1.2 - 1.5 cc R3 - R4	Hyundai Era, Accent, Getz, i10, i20		<p>557 gr Torque : 45 Nm 2nd Torque Option : 12.7 Nm + 90 °</p>	Connecting Rod STD	BMY0601 1 pc.24x10x4cm
	Kia Cerato, Rio			Connecting Rod SEMI	BMY0601SEMI 1 pc.24x10x4cm
				Bushing Bimetal Locked-Straight	BMY0601B 4 pcs.10x6x4cm
				Bolt - 10.9 M7x1 L: 38 mm	BMY0806CB 8 pcs.10x6x4cm
				Con. Rod OEM : 23510 2A701	
2 Hyundai - Kia D3EA - D4EA -D4EB 1.5 - 2.0 - 2.2cc R3 - R4 - R5	Hyundai Accent, Elntra, Tuscon, Santafe CRDI, i30		<p>885 gr Torque : 50 Nm</p>	Connecting Rod STD	BMY0602 1 pc.24x10x4cm
	Kia Cee'd, Sportage, Cerato			Connecting Rod SEMI	BMY0602SEMI 1 pc.24x10x4cm
				Bushing Bimetal Locked-Straight	BMY0602B 4 pcs.10x6x4cm
				Bolt - 10.9 M8x1 L: 47mm	
				Con. Rod OEM : 23510 27300	
3 Hyundai D4BF, D4BB, D4BH Mitsubishi 4D55T, 4D56 2.5 cc R4	Hyundai Starex/ H100		<p>1040 gr Torque : 60 Nm</p>	Connecting Rod STD	BMY1303 1 pc.24x10x4cm
	Mitsubishi L200/300			Connecting Rod SEMI	BMY1303SEMI 1 pc.24x10x4cm
				Bushing Bimetal Locked-Straight	BMY1303B 4 pcs.10x6x4cm
				Bolt - 10.9 M9x1 L:46 mm	
				Con. Rod OEM : MD371001 23510 42010	

Engine Type	Models	Picture	Sizes (mm)	Products	BMY Reference
<p>4</p> <p>Hyundai - Mitsubishi 4D56U 4D56T</p> <p>2.5 cc</p> <p>R4</p>  	<p>Hyundai H100 (2015-...)</p> <p>Mitsubishi L200/300</p>		 <p>1040 gr Torque : 60 Nm</p>	<p>Connecting Rod STD</p> <p>Connecting Rod SEMI</p> <p>Bushing Bimetal Locked-Straight</p> <p>Bolt - 10.9 M9x1 L: 46 mm</p> <p>Con. Rod OEM : 1115 A345</p> 	<p>BMY1305 1 pc.24x10x4cm</p> <p>BMY1305SEMI 1 pc.24x10x4cm</p> <p>BMY1305B 4 pcs.10x6x4cm</p>
<p>5</p> <p>Hyundai - KIA Dodge D4CB, D4BC</p> <p>2.5 CRDI</p> <p>R4</p> 	<p>Hyundai H350, H100, H1, Porter, Starex</p> <p>Kia Bongo, K2500, Sorento</p> <p>Dodge H100</p>		 <p>1188gr Torque : 80 Nm</p>	<p>Connecting Rod STD</p> <p>Connecting Rod SEMI</p> <p>Bushing Bimetal Locked-Straight</p> <p>Bolt - 10.9 M10x1,25 L: 49mm</p> <p>Con. Rod OEM : 23510-4A000, 235104A500, 235104A710</p> 	<p>BMY0603 1 pc.24x10x4cm</p> <p>BMY0603SEMI 1 pc.24x10x4cm</p> <p>BMY0603B 4 pcs.10x6x4cm</p>











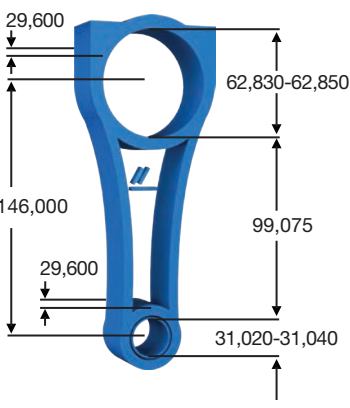



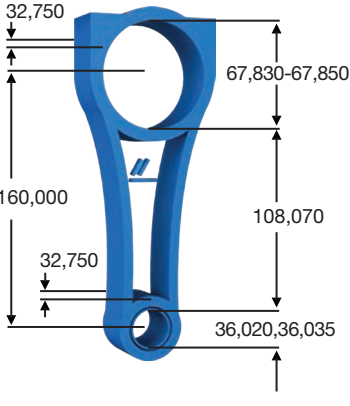



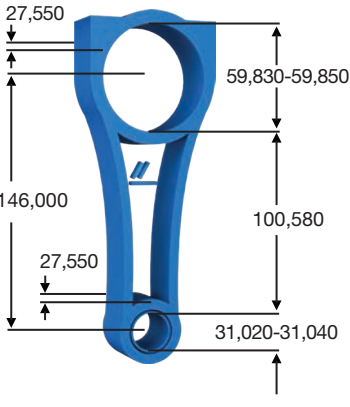

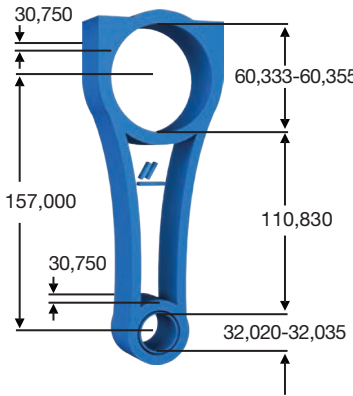

Engine Type	Models	Picture	Sizes (mm)	Products	BMY Reference
1 Isuzu 4HF1 4.3 cc R4	NKR66, NPR66, Champion MD23, MD25, MD27			Connecting Rod STD BMY0401 1 pc.30x12x6cm	Connecting Rod SEMI BMY0401SEMI 1 pc.30x12x6cm
				Bushing Bimetal Locked-Straight BMY0401B 4 pcs.10x6x4cm	Bolt - 10.9 M13x1,25 L:58 Con. Rod OEM : 897135032351
  				  	
2 Isuzu 4HE1-T 4.7 cc R4	NQR, NQR3D, NPR, NPS4x4, Turkuaz, Euro II/ III			Connecting Rod STD BMY0402 1 pc.30x12x6cm	Connecting Rod SEMI BMY0402SEMI 1 pc.30x12x6cm
				Bushing Bimetal Locked-Straight BMY0402B 4 pcs. 10x6x4cm	Bolt - 12.9 M13x1,25 L: 57 Con. Rod OEM: 897135032351
   				  	
3 Isuzu 4HK1-6HK1-TCS 5.2 cc R4 - R6	NQR86, Turkuaz Euro III/IV C.Rail			Connecting Rod STD BMY0403 1 pc.30x12x6cm	Connecting Rod SEMI BMY0403SEMI 1 pc.30x12x6cm
				Bushing Bimetal Locked-Straight BMY0402B 4 pcs. 10x6x4cm	Bolt - 12.9 M13x1,25 L: 57 Con. Rod OEM : 894399661251
   				  	

Engine Type	Models	Picture	Sizes (mm)	Products	BMY Reference
<p>4</p> <p>Isuzu 4JA1 2.5 cc R4</p>	<p>TFR54, Cameo, Panther, Wizard, Opel Frontera</p>		<p>1105 gr Torque : 100 Nm</p>	<p>Connecting Rod STD BMY0405 1 pc.24x10x4cm</p> <p>Connecting Rod SEMI BMY0405SEMI 1 pc.24x10x4cm</p> <p>Bushing Bimetal Locked-Straight BMY0405B 4 pcs.10x6x4cm</p> <p>Bolt - 12.9 M11x1,25 L: 58 mm</p> <p>Con. Rod OEM : 894333119</p>	
<p>5</p> <p>Isuzu 4JA1-T/C 2.5 cc R4</p>	<p>D-Max Pick Up 4x2/4x4, Cameo, Panther, Wizard, Opel Frontera</p>		<p>1065 gr Torque : 100 Nm</p>	<p>Connecting Rod STD BMY0406 1 pc.24x10x4cm</p> <p>Connecting Rod SEMI BMY0406SEMI 1 pc.24x10x4cm</p> <p>Bushing Bimetal Locked-Straight BMY0405B 4 pcs. 10x6x4cm</p> <p>Bolt - 12.9 M11x1,25 L: 58 mm</p> <p>Con. Rod OEM : 894333119</p>	
<p>6</p> <p>Isuzu 4JB1-T 2.8 cc R4</p>	<p>NKR55 Karsan J9 Premier</p>	<p>1185 gr Torque : 80 Nm</p>	<p>Connecting Rod STD BMY0407 1 pc.24x10x4cm</p> <p>Connecting Rod SEMI BMY0407SEMI 1 pc.24x10x4cm</p> <p>Bushing Bimetal Locked-Straight BMY0405B 4 pcs. 10x6x4cm</p> <p>Bolt - 10.9 M10x1,25 L:49 mm</p> <p>Con. Rod OEM : 8943296920</p>		

Engine Type	Models	Picture	Sizes (mm)	Products	BMY Reference
7 Isuzu 4JK1 Euro4 - 5 2.5 cc Isuzu 4JJ1 Euro4 - 5 3.0 cc R4	D-Max NPR, NLR, NNR		<p>32,900</p> <p>55,985-56,010</p> <p>158,000</p> <p>113,000</p> <p>32,900</p> <p>34,020-34,035</p> <p>1170 gr Torque : 80 Nm</p>	Connecting Rod STD	BMY0408 1 pc.24x10x4cm
				Connecting Rod SEMI	BMY0408SEMI 1 pc.24x10x4cm
				Bushing Bimetal Locked-Straight	BMY0408B 4 pcs. 10x6x4cm
				Bolt - 10.9 M10x1,25 L:49 mm	
				Cross References Con. Rod OEM : 8973577163	











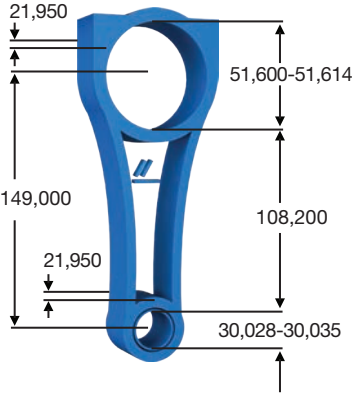

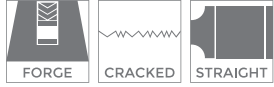

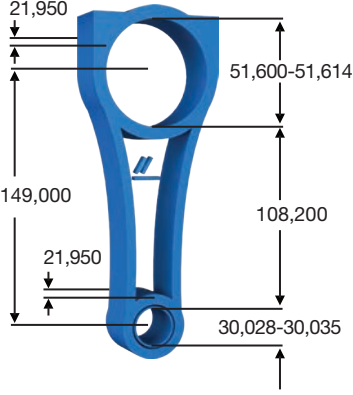

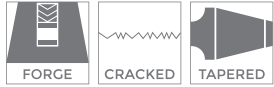

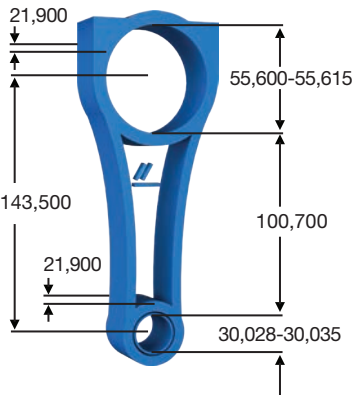



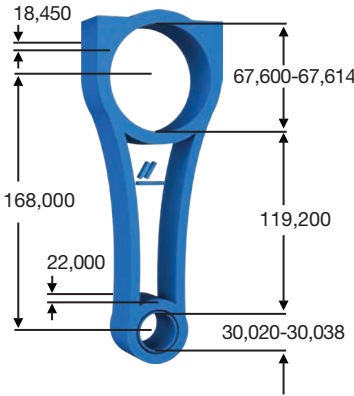

Engine Type	Models	Picture	Sizes (mm)	Products	BMY Reference
1 Iveco - Fiat F1AE 2.3 cc R4	Iveco Daily		 <p>1140 gr Torque : 80 Nm 2nd Torque Option : 40 Nm + 60 °</p>	Connecting Rod STD	BMY1405 1 pc.30x12x6cm
	Fiat Ducato			Connecting Rod SEMI	BMY1405SEMI 1 pc.30x12x6cm
	UAZ Patriot			Bushing Bimetal Locked-Straight	BMY1405B 4 pcs. 10x6x4cm
	Karsan Jest/J10			Bolt M10x1,25 L: 49 mm	BMY1405CB 8 pcs. 10x6x4cm
				Con. Rod OEM: 504 341 501 504 057 276	
					
2 Iveco - Fiat 3.0 JTD F1CE Mitsubishi 4P10-7AT/T2/T4/T6 3.0 cc R4	Iveco Daily, Fiat Ducato Massif		 <p>1340 gr Torque : 80 Nm</p>	Connecting Rod STD	BMY1406 1 pc.30x12x6cm
	Citroen Jumper			Connecting Rod SEMI	BMY1406SEMI 1 pc.30x12x6cm
	Mitsubishi Fuso Canter 8B/9BL			Bushing Bimetal Locked-Straight	BMY1406B 4 pcs. 10x6x4cm
				Bolt - 10.9 M10x1,25 L:49 mm	
				Con. Rod OEM: 504 341 496	
					
3 Iveco - Fiat F1AF-F1AG 2.3 cc R4 Euro 6	Iveco Daily		 <p>985 gr Torque : 60 Nm</p>	Connecting Rod STD	BMY1407 1 pc.24x10x4cm
	Fiat Ducato			Connecting Rod SEMI	BMY1407SEMI 1 pc.24x10x4cm
				Bushing Bimetal Locked-Straight	BMY1407B 4 pcs. 10x6x4cm
				Bolt - 10.9 M9x1 L:46 mm	BMY0805CB 8 pcs. 10x6x4cm
				Con. Rod OEM: 5801841535, 5801842210 5802116073	
					

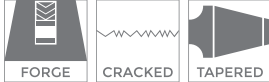
Engine Type	Models	Picture	Sizes (mm)	Products	BMV Reference
4 Iveco - Fiat Sofim 8140/S8W/S9W 2.8 cc R4	Iveco Daily Fiat Ducato Renault Master, Mascott Opel Movano Citroën Jumper Peugeot Boxer		 1290 gr Torque : 80 Nm	Connecting Rod STD Connecting Rod SEMI Bushing Bimetal Locked-Straight Bolt - 10.9 M10x1,25 L:58 mm Con. Rod OEM: 7473171	BMV0803 1 pc.24x10x4cm BMV0803SEMI 1 pc.24x10x4cm BMV0803B 4 pcs. 10x6x4cm
   		  			

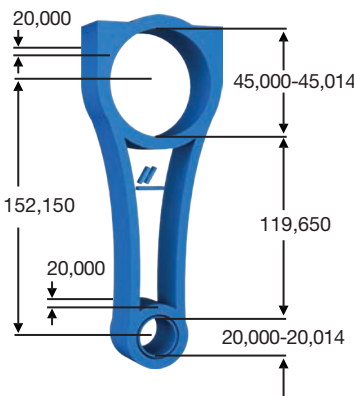

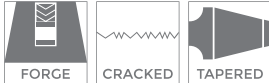
Engine Type	Models	Picture	Sizes (mm)	Products	BMY Reference
1 Land Rover 276DT, TDV6, TVM Peugeot UHZ(DT17) V6 - 2.7 cc Land Rover 368DT V8 - 3.6 cc 2.7 - 3.6 cc	Discovery III - IV Range Rover - Sport Jaguar S-Type, XF, XJ Peugeot 407, 607/Coupe/SW		<p>683 gr Torque : 45 Nm 2nd Torque Option : 20 Nm + 80 °</p>	Connecting Rod STD Connecting Rod SEMI Bushing Bimetal Locked-Straight Bolt - 10.9 M8x1 L: 47mm	BMY0201 2 pcs.30x12x6cm BMY0201SEMI 2 pcs.30x12x6cm BMY0201B 3 pcs. 10x6x4cm BMY0201CB 12 pcs.10x6x4cm Con. Rod OEM : DE116250 DA6625, LR010297
2 Land Rover AJD V6-DT20 306DT, 30DDTX Euro 5 3.0 cc V6	Discovery IV Range Rover IV - Sport Jaguar XF, XF Sportbrake, XJ Citroen C5 III, C6 Peugeot 407 Coupe		<p>712 gr Torque : 45 Nm</p>	Connecting Rod STD Connecting Rod SEMI Bushing Bimetal Locked-Straight Bolt - 10.9 M8x1 L: 47mm	BMY0202 2 pcs.30x12x6cm BMY0202SEMI 2 pcs.30x12x6cm BMY0202B 3 pcs.10x6x4cm BMY0201CB 12 pcs.10x6x4cm Con. Rod OEM : DA6626, LR051508, LR038168
3 Land Rover 204DTA AJ200D 241ps Jaguar JLR AJ20D 240ps 2.0 (1999) cc R4 Euro 6	Range Rover Evoque Range Rover Evoque Convertible Range Rover Velar Discovery V Jaguar XE, XF, F-Pace		<p>817 gr Torque : 50 Nm</p>	Connecting Rod STD Connecting Rod SEMI Bushing Bimetal Locked-Straight Bolt - 10.9 M8x1 L: 47mm	BMY0203 1 pc.30x12x6cm BMY0203SEMI 1 pc.30x12x6cm BMY0203B 4 pcs. 10x6x4cm BMY0201CB 8 pcs. 10x6x4cm Con. Rod OEM: LR124261

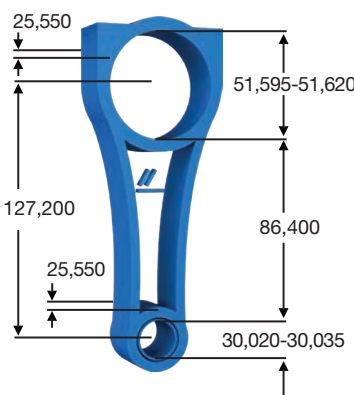

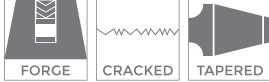

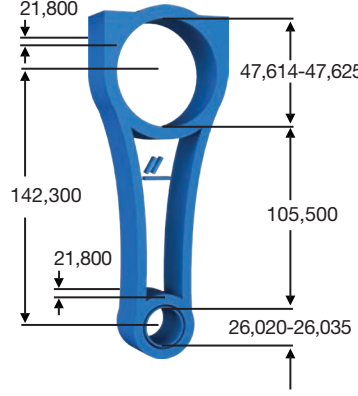





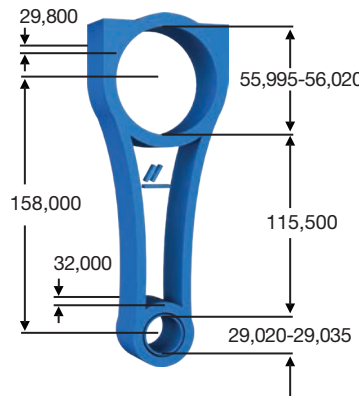



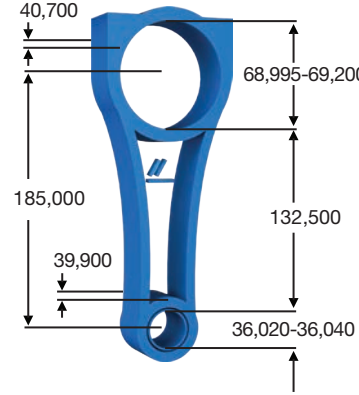

Engine Type	Models	Picture	Sizes (mm)	Products	BMY Reference
1 Mercedes-Benz OM611, OM613 2.1 - 2.2 - 3.2 cc R4 - R6	Mercedes-Benz C-E-S-Class, Vito, Sprinter		 <p>760 gr Torque : 45 Nm 2nd Torque Option : 25 Nm + 90 °</p>	Connecting Rod STD	BMY0713 1 pc.24x10x4cm
				Connecting Rod SEMI	BMY0713SEMI 1 pc.24x10x4cm
				Bushing Bimetal Locked-Straight	BMY0713B 4 pcs. 10x6x4cm
				Bolt - 10.9 M8x1 L:47 mm	BMY0714CB 8 pcs. 10x6x4cm
				Con. Rod OEM : 611 030 0520	
					
2 Mercedes-Benz OM612, OM646 2.2 - 2.7 cc R4 - R5	Mercedes-Benz C-E-CLK-ML-G Class, Sprinter, Vito, Viano		 <p>750 gr Torque : 45 Nm 2nd Torque Option : 25 Nm + 90 °</p>	Connecting Rod STD	BMY0714 1 pc.24x10x4cm
				Connecting Rod SEMI	BMY0714SEMI 1 pc.24x10x4cm
				Bushing Bimetal Locked-Straight	BMY0714B 4 pcs. 10x6x4cm
				Bolt - 10.9 M8x1 L:47 mm	BMY0714CB 8 pcs. 10x6x4cm
				Con. Rod OEM : 646 030 0020	
					
3 Mercedes-Benz OM651 Jeep OM651 Freightliner OM651 2.2 cc R4	Mercedes-Benz Vito, A-B-C-E GLK-CLS, MLS -SLK Class, Viano, Sprinter Jeep Compass 2.2. CRD Freightliner Sprinter		 <p>760 gr Torque : 45 Nm 2nd Torque Option : 25 Nm + 90 °</p>	Connecting Rod STD	BMY0715 1 pc.24x10x4cm
				Connecting Rod SEMI	BMY0715SEMI 1 pc.24x10x4cm
				Bushing Bimetal Locked-Straight	BMY0714B 4 pcs. 10x6x4cm
				Bolt - 10.9 M8x1 L:47 mm	BMY0714CB 8 pcs. 10x6x4cm
				Con. Rod OEM : 651 030 0020	
					

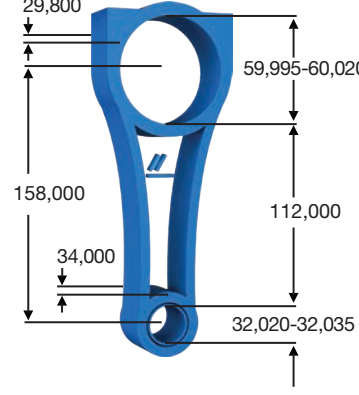

Engine Type	Models	Picture	Sizes (mm)	Products	BMY Reference
4 Mercedes-Benz OM642 3.0cc - V6	Vito, Mixto, Sprinter, E300D, CLK, GLK, GLE, GLS, C300 320/350 CDI, Viano, CLK 320 CDI, CLS 320 CDI, CLS 350 BlueTEC, CLS 350 CDI, E280/300/320/350 BlueTEC CDI, G280/300/320/350 CDI/d GL 320/350 CDI, ML 280/300/320/350 BlueTEC CDI, R280/300/320/350 CDI, S320/350 BlueTEC/CDI, X350d		 <p>870gr Torque : 60 Nm</p>	Connecting Rod STD Connecting Rod SEMI Bolt - 10.9 M8x1 L:47 mm	BMY0716 1 pc.30x12x6cm BMY0716SEMI 1 pc.30x12x6cm
					
5 Mercedes-Benz M270.910, M274.910 2014 → 1.6cc R4	C180/CGI, E180, SLC 180, A160, A200, B160, B180, B200, CLA180, CLA200, GLA180, GLA200		 <p>440gr Torque : 60 Nm</p>	Connecting Rod STD Connecting Rod SEMI Bolt - 10.9 M8x1 L: 38 mm	BMY0717 1 pc.26x10x4cm BMY0717SEMI 1 pc.26x10x4cm
					
6 Mercedes-Benz OM626 Renault R9M 1.6 cc R4	Mercedes-Benz A, B, C, CLA-Class, Citan		 <p>655 gr Torque : 60 Nm 2nd Torque Option : 20 Nm + 45 °</p>	Connecting Rod STD Connecting Rod SEMI Bushing Bimetal Locked-Straight Bolt - 10.9 M9x1 L:42 mm	BMY0919 1 pc.24x10x4cm BMY0919SEMI 1 pc.24x10x4cm BMY0919B 4 pcs. 10x6x4cm BMY0901CB 8 pcs. 10x6x4cm
					

Engine Type	Models	Picture	Sizes (mm)	Products	BMY Reference
7					
Mercedes-Benz OM607, OM608	Mercedes-Benz A, B, CLA, GLA Class, Citan			Connecting Rod STD	BMY0902 1 pc.24x10x4cm
Renault K9K 846, K9K 608, 872	Infiniti Q30			Connecting Rod SEMI	BMY0902SEMI 1 pc.24x10x4cm
1.5 cc - R4	Renault Megane IV, Kadjar, Scenic IV, Clio Captur			Bushing Bimetal Locked-Straight	BMY0901B 4 pcs. 10x6x4cm
Euro 5/6	Nissan Note, Micra			Bolt - 10.9 M9x1 L:42 mm	BMY0901CB 8 pcs. 10x6x4cm
Used in forged-steel piston engines. Es wird in geschmiedeten Stahlkolbenmotoren. Dövme çelik pistonlu motorlarda kullanılır.	Dacia Lodgy			Con. Rod OEM : 607 030 0420	



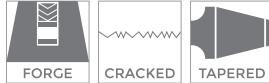

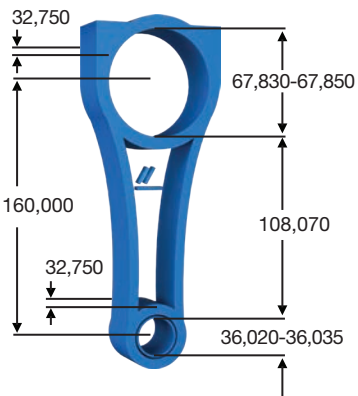

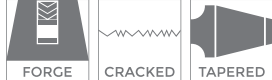



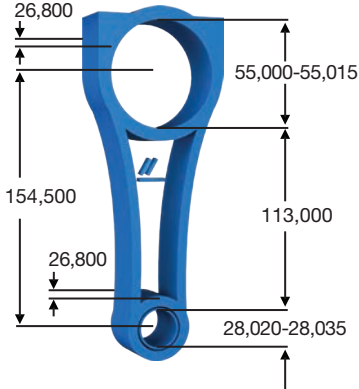







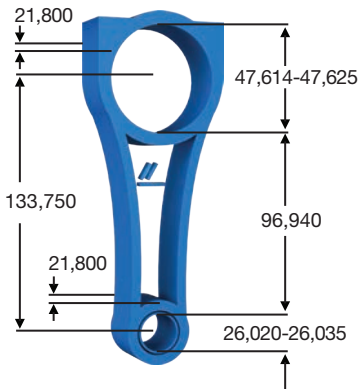





560 gr | Torque : 60 Nm
2nd Torque Option :
20 Nm + 45 °

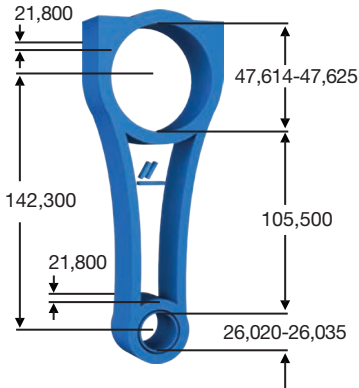









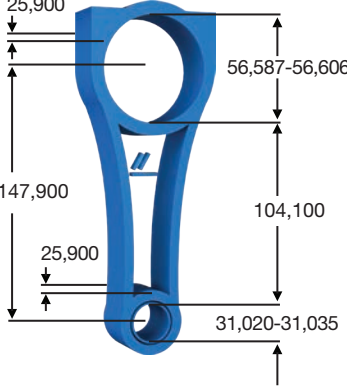

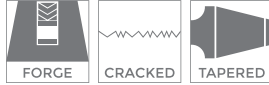
Engine Type	Models	Picture	Sizes (mm)	Products	BMY Reference
1 Mitsubishi 4D55T, 4D56 Hyundai D4BF, D4BB, D4BH 2.5 cc R4	Mitsubishi L200/300 Hyundai Starex/H100		 1040 gr Torque : 60 Nm	Connecting Rod STD Connecting Rod SEMI Bushing Bimetal Locked-Straight Bolt - 10.9 M9x1 L:46 mm	BMY1303 1 pc.24x10x4cm BMY1303SEMI 1 pc.24x10x4cm BMY1303B 4 pcs. 10x6x4cm Con. Rod OEM : MD371001 2351042010
   					
2 Mitsubishi 4D34T 3.9 cc R4	Mitsubishi Canter FE659T		 1940 gr Torque : 150 Nm	Connecting Rod STD Connecting Rod SEMI Bushing Bimetal Locked-Straight Bolt - 12.9 M12,5x1,25 L:68	BMY1304 1 pc.24x10x4cm BMY1304SEMI 1 pc.24x10x4cm BMY1304B 4 pcs. 10x6x4cm Con. Rod OEM : ME012266
  					
3 Mitsubishi 4D56 TDI, 4D56T, 4D56U 2.5 cc R4	Mitsubishi L200/300 Hyundai H100 (2015-...)		 1035 gr Torque : 60 Nm	Connecting Rod STD Connecting Rod SEMI Bushing Bimetal Locked-Straight Bolt - 10.9 M9x1 L:46 mm	BMY1305 1 pc.24x10x4cm BMY1305SEMI 1 pc.24x10x4cm BMY1305B 4 pcs. 10x6x4cm Con. Rod OEM : 1115 A345, 1115 A035, 1115A343
   					

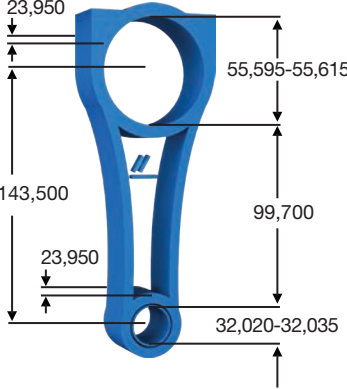

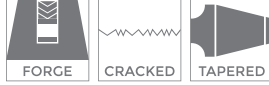

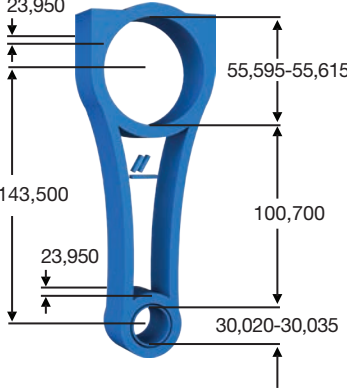

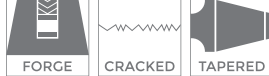



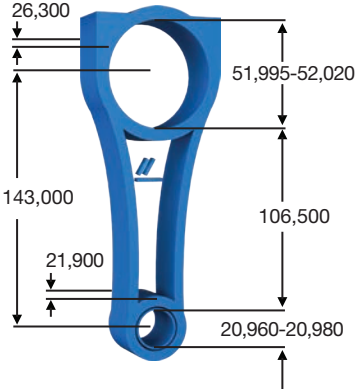





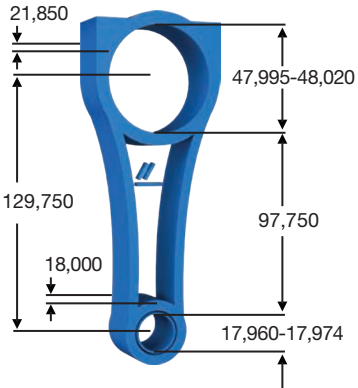

Engine Type	Models	Picture	Sizes (mm)	Products	BMY Reference
<p>4</p> <p>Mitsubishi 4P10-7AT/T2/T4/T6</p> <p>Fiat/Iveco 3.0 JTD F1CE</p> <p>3.0 cc</p> <p>R4</p>	<p>Mitsubishi Fuso Canter 8B/9BL</p> <p>Fiat Ducato</p> <p>Iveco Daily, Massif</p> <p>Citroen Jumper</p>		 <p>1340 gr Torque : 85 Nm</p>	<p>Connecting Rod STD</p> <p>Connecting Rod SEMI</p> <p>Bushing Bimetal Locked-Straight</p> <p>Bolt - 10.9 M10x1,25 L:49 mm</p> <p>Con. Rod OEM : 504 341 496</p>	<p>BMY1406 1 pc.30x12x6cm</p> <p>BMY1406SEMI 1 pc.30x12x6cm</p> <p>BMY1406B 4 pcs. 10x6x4cm</p>
					



Engine Type	Models	Picture	Sizes (mm)	Products	BMY Reference
1 Nissan YD22/ YD25 2.5 cc R4	Nissan Primera, Almera X-Trail, Navara, Frontier, Pathfinder		 <p>26,800 55,000-55,015 154,500 26,800 113,000 28,020-28,035</p> <p>940 gr Torque : 60 Nm</p>	Connecting Rod STD Connecting Rod SEMI Bushing Bimetal Locked-Straight Bolt - 10.9 M9x1 L:46 mm	BMY1201 1 pc.24x10x4cm BMY1201SEMI 1 pc.24x10x4cm BMY1201B 4 pcs. 10x6x4cm Con. Rod OEM : 12100-EB33A
  	  				
2 Nissan - Renault K9K 1.5 cc R4	Nissan Micra, Qashqai, Juke		 <p>21,800 47,614-47,625 133,750 21,800 96,940 26,020-26,035</p> <p>535 gr Torque : 60 Nm 2nd Torque Option : 20 Nm + 45 °</p>	Connecting Rod STD Connecting Rod SEMI Bushing Bimetal Locked-Straight Bolt - 10.9 M9x1 L:42 mm	BMY0901 1 pc.24x10x4cm BMY0901SEMI 1 pc.24x10x4cm BMY0901B 4 pcs. 10x6x4cm BMY0901CB 8 pcs. 10x6x4cm Con. Rod OEM : 770 147 5074
  	  				
3 Renault K9K 846, K9K 608, 872 Mercedes-Benz OM607, OM608 1.5 cc - R4 Euro 5/6 Used in forged-steel piston engines. Es wird in geschmiedeten Stahkolbenmotoren. Dövmə çelik pistonlu motorlarda kullanılır.	Nissan Note, Micra Infiniti Q30 Mercedes-Benz A, B, CLA, GLA Class, Citan Renault Megane IV, Kadjar, Scenic IV, Clio Captur Dacia Lodgy		 <p>21,800 47,614-47,625 142,300 21,800 105,500 26,020-26,035</p> <p>560 gr Torque : 60 Nm 2nd Torque Option : 20 Nm + 45 °</p>	Connecting Rod STD Connecting Rod SEMI Bushing Bimetal Locked-Straight Bolt - 10.9 M9x1 L:42 mm	BMY0902 1 pc.24x10x4cm BMY0902SEMI 1 pc.24x10x4cm BMY0901B 4 pcs. 10x6x4cm BMY0901CB 8 pcs. 10x6x4cm Con. Rod OEM : 121008820R
   	  				

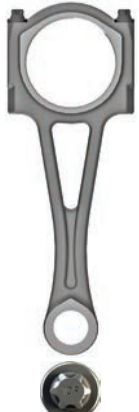
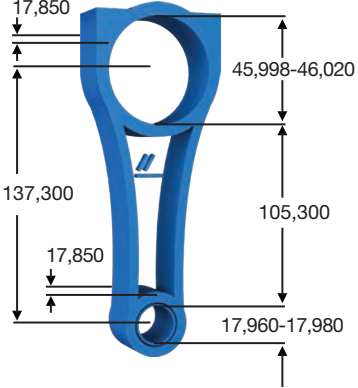









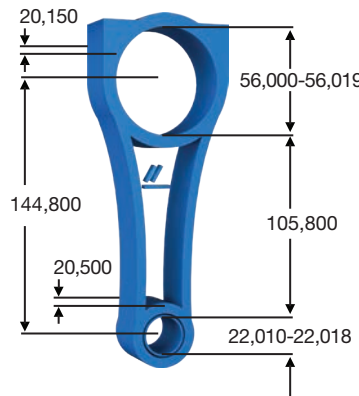

Engine Type	Models	Picture	Sizes (mm)	Products	BMY Reference
<p>4</p> <p>Nissan - Renault G9U</p> <p>2.5 cc</p> <p>R4</p>	Nissan Interstar		 <p>25,900 56,587-56,606 147,900 104,100 25,900 31,020-31,035</p> <p>870 gr Torque : 60 Nm 2nd Torque Option : 20 Nm + 45 °</p>	<p>Connecting Rod STD BMY0913 1 pc.24x10x4cm</p> <p>Connecting Rod SEMI BMY0913SEMI 1 pc.24x10x4cm</p> <p>Bushing Bimetal Locked-Straight BMY0913B 4 pcs. 10x6x4cm</p> <p>Bolt - 10.9 M9x1 L:42 mm BMY0901CB 8 pcs. 10x6x4cm</p> <p>Con. Rod OEM : 770 147 3615</p>	 
<p>5</p> <p>Nissan - Renault M9R</p> <p>2.0 cc</p> <p>R4</p>	Nissan Qashqai, X-Trail		 <p>23,950 55,595-55,615 143,500 99,700 23,950 32,020-32,035</p> <p>730 gr Torque : 60 Nm 2nd Torque Option : 20 Nm + 45 °</p>	<p>Connecting Rod STD BMY0915 1 pc.24x10x4cm</p> <p>Connecting Rod SEMI BMY0915SEMI 1 pc.24x10x4cm</p> <p>Bushing Bimetal Locked-Straight BMY0915B 4 pcs. 10x6x4cm</p> <p>Bolt - 10.9 M9x1 L:42 mm BMY0901CB 8 pcs. 10x6x4cm</p> <p>Con. Rod OEM : 770 147 7831</p>	 
<p>6</p> <p>Nissan - Renault M9R</p> <p>2.0 cc</p> <p>R4</p>	Nissan Qashqai, X-Trail		 <p>23,950 55,595-55,615 143,500 100,700 23,950 30,020-30,035</p> <p>760 gr Torque : 60 Nm 2nd Torque Option : 20 Nm + 45 °</p>	<p>Connecting Rod STD BMY0916 1 pc.24x10x4cm</p> <p>Connecting Rod SEMI BMY0916SEMI 1 pc.24x10x4cm</p> <p>Bushing Bimetal Locked-Straight BMY0916B 4 pcs. 10x6x4cm</p> <p>Bolt - 10.9 M9x1 L:42 mm BMY0901CB 8 pcs. 10x6x4cm</p> <p>Con. Rod OEM : 770 147 7831</p>	 

Engine Type	Models	Picture	Sizes (mm)	Products	BMY Reference
7 Nissan - Renault G9T 2.2 cc R4	Nissan Interstar, Primastar		<p>25,900 56,590-56,610 149,900 106,100 25,900 31,020-31,035</p> <p>873 gr Torque : 60 Nm 2nd Torque Option : 20 Nm + 45 °</p>	Connecting Rod STD BMY0917 1 pc.24x10x4cm Connecting Rod SEMI BMY0917SEMI 1 pc.24x10x4cm Bushing Bimetal Locked-Straight BMY0913B 4 pcs. 10x6x4cm Bolt - 10.9 M9x1 L:42 mm BMY0901CB 8 pcs. 10x6x4cm	Con. Rod OEM : 770 147 2847
8 Nissan - Renault M9T 2.3 cc R4	Nissan NV400, Navara, Qashqai, X-Trail, Primastar Mercedes-Benz X-Class		<p>23,950 56,587-56,610 157,250 112,950 23,950 32,020-32,035</p> <p>805 gr Torque : 60 Nm 2nd Torque Option : 20 Nm + 45 °</p>	Connecting Rod STD BMY0918 1 pc.24x10x4cm Connecting Rod SEMI BMY0918SEMI 1 pc.24x10x4cm Bushing Bimetal Locked-Straight BMY0915B 4 pcs. 10x6x4cm Bolt - 10.9 M9x1 L:42 mm BMY0901CB 8 pcs. 10x6x4cm	Con. Rod OEM : 121004942R
9 Nissan-Renault R9M Mercedes-Benz OM626 1.6 cc R4	Nissan Juke, Almera, Cube, Micra, Note, NV200		<p>25,550 51,595-51,620 127,200 86,400 25,550 30,020-30,035</p> <p>655 gr Torque : 60 Nm 2nd Torque Option : 20 Nm + 45 °</p>	Connecting Rod STD BMY0919 1 pc.24x10x4cm Connecting Rod SEMI BMY0919SEMI 1 pc.24x10x4cm Bushing Bimetal Locked-Straight BMY0916B 4 pcs. 10x6x4cm Bolt - 10.9 M9x1 L:42 mm BMY0901CB 8 pcs. 10x6x4cm	Con. Rod OEM : 121006304R 121000425R, 1210000Q0K, 95518876

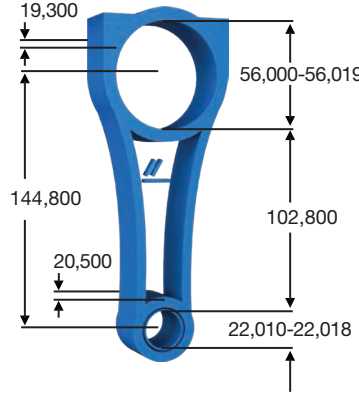









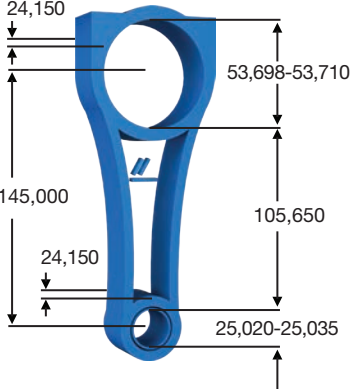







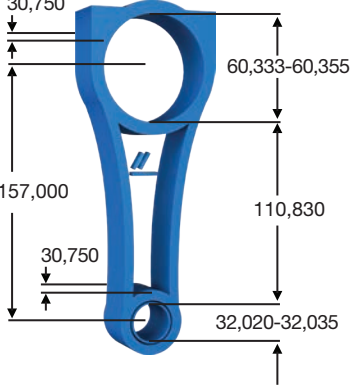



Engine Type	Models	Picture	Sizes (mm)	Products	BMY Reference
1 Opel OHC C20LET/NE (8V,16V) 1.8 - 2.0 cc R4	Opel Vectra, Astra, Omega Saab 9-3 Lotus Europa S Cadillac BLS		 <p>640 gr Torque : 60 Nm</p>	Connecting Rod STD Bolt - 10.9 M9x1 L:42 mm	BMY1501 1 pc.24x10x4cm
  	  				
2 Opel OHC X16/ Z16 (8V,16V) 1.6 cc R4	Opel Corsa, Astra, Vectra Chavrolet Aveo		 <p>423 gr Torque : 50 Nm</p>	Connecting Rod STD Bolt - 10.9 M8x1 L:41 mm	BMY1502 1 pc.24x10x4cm
  	  				
3 Opel Z12XEP, X12XEP A14XEP, Z14XEP, X14XEP Twinport 1.2 - 1.4 cc R4	Opel/Vauxhall Corsa/Holden Tigra, Astra, Meriva, Astra J Zafira Tourer, Combo C, Adam, Mokka Chevrolet Cruze, Volt Buick Encore		 <p>355 gr Torque : 45 Nm</p>	Connecting Rod STD Bolt - 10.9 M7x1 L:38 mm	BMY1503 1 pc.24x10x4cm
  	 				



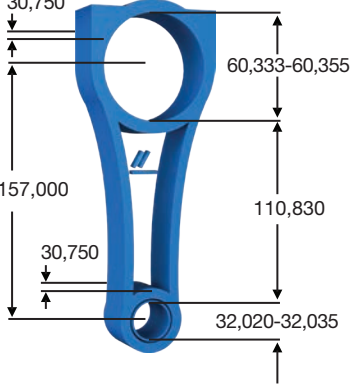



Engine Type	Models	Picture	Sizes (mm)	Products	BMY Reference	
<p>4</p> <p>Opel/Vauxhall A20DTH, A20DTJ, Y20DTJ, Z20DTJ</p> <p>Fiat D20AA Euro5</p> <p>2.0 cc</p> <p>R4</p>	<p>Opel Insignia, Astra J</p> <p>Fiat Freemont, Doblo, Bravo Lancia/Chrysler Delta</p> <p>Alfa Romeo Brera, Spider, 159, Giulietta</p>		<p>740 gr Torque : 70 Nm 2nd Torque Option : 25 Nm + 60 °</p>	<p>Connecting Rod STD BMY1504 1 pc.24x10x4cm</p> <p>Connecting Rod SEMI BMY1504SEMI 1 pc.24x10x4cm</p> <p>Bushing Bimetal Locked-Straight BMY1504B 4 pcs. 10x6x4cm</p> <p>Bolt - 10.9 M9x1 L:42 mm BMY0805CB 8 pcs. 10x6x4cm</p> <p>Con. Rod OEM : 555 684 66, 555 978 94 Without Bearing Lug (for with Lug BMY1404)</p>		
<p>5</p> <p>Opel - Vauxhall GM B16DTC, DTE, DTH, B16DTJ, DTL, DTN, DTR, DTU Euro 5, Euro 6</p> <p>1.6 cc</p> <p>R4</p>	<p>Astra J/K, Crossland X, Mervia B, Mokka X, Insignia A/B, Zafira C</p> <p>Buick Regal</p>		<p>600 gr Torque : 60 Nm 2nd Torque Option : 25 Nm + 60 °</p>	<p>Connecting Rod STD BMY1506 1 pc.24x10x4cm</p> <p>Connecting Rod SEMI BMY1506SEMI 1 pc.24x10x4cm</p> <p>Bushing Bimetal Locked-Straight BMY1506B 4 pcs. 10x6x4cm</p> <p>Bolt - 10.9 M9x1 L: 46 mm</p> <p>Con. Rod OEM : 555 88 337, 555 01 494</p>		
<p>6</p> <p>Opel - Vauxhall GM A16 LET, A16 XER Euro 5, Euro 6</p> <p>1.6 cc</p> <p>R4</p>	<p>Opel Vauxhall, Astra H, J, Insignia A, Mokka</p> <p>Chevrolet Cruze, Aveo, Sonic, Trax</p> <p>Buick Excelle</p>		<p>420 gr Torque : 45 Nm 2nd Torque Option : 10 Nm + 60 ° + 15 °</p>	<p>Connecting Rod STD BMY1507 1 pc.24x10x4cm</p> <p>Connecting Rod SEMI BMY1507SEMI 1 pc.24x10x4cm</p> <p>Bushing Bimetal Locked-Straight BMY1507B 4 pcs. 10x6x4cm</p> <p>Bolt - 10.9 M8x1 L : 38 mm</p> <p>Con. Rod OEM : 622 111, 555 684 67</p>		



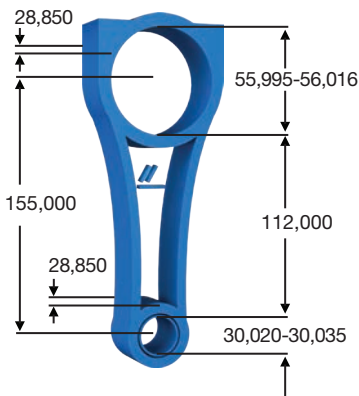

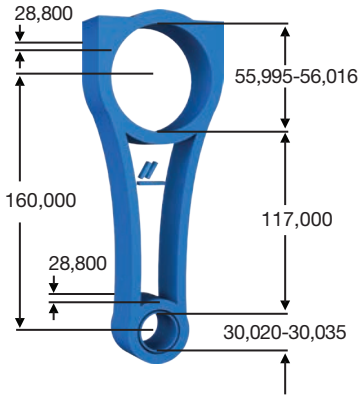

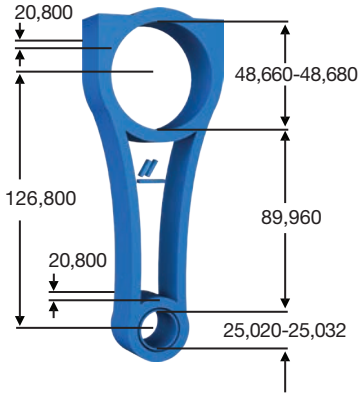

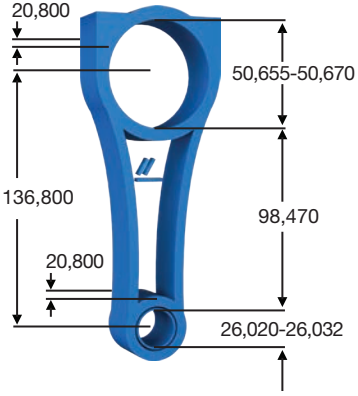

Engine Type	Models	Picture	Sizes (mm)	Products	BMY Reference
<p>7</p> <p>Opel-Vauxhall Chevrolet - GM A13DTC Euro 5, A13DTE, A13DTR Euro 5, A13FD Euro 5, B13DTC Euro 5, B13DTE, B13DTR, D13A Euro 4, Y13DT Euro 3/4, Z13DT Euro 4, Z13DTE Euro 4, Z13DTH Euro 4, Z13DTI Euro 4, Z13DTJ Euro 4, Z13DTR Euro 4, CDTI</p> <p>1.3 cc</p> <p>R4</p>	<p>Fiat Albea, Doblò, Fiorino, Grande Punto, Linea, 500, Palio, Panda, Punto Alfa Romeo, MiTo</p> <p>Lancia Musa, Ypsilon Suzuki Swift, SX4, Splach</p>		<p>450 gr Torque : 45 Nm 2nd Torque Option : 20Nm + 40 °</p>	<p>Connecting Rod STD</p> <p>Connecting Rod SEMI</p> <p>Bushing Bimetal Locked-Straight</p> <p>Bolt - 10.9 M8x1 L:38 mm</p> <p>Con. Rod OEM : 735 012 29, 552 086 24</p>	<p>BMY1401 1 pc.24x10x4cm</p> <p>BMY1401SEMI 1 pc.24x10x4cm</p> <p>BMY1401B 4 pcs. 10x6x4cm</p> <p>BMY1401CB 8 pcs. 10x6x4cm</p>
<p>8</p> <p>Opel Z19DT/H</p> <p>1.9 cc</p> <p>R4</p>	<p>Alfa Romeo 146,147,159,GT Cadillac BLS Fiat Doblo, Bravo, Punto Fiat Croma, Marea, Stilo Lancia Delta, Lybra, Musa Opel Signum, Vectra C Opel Zafira B Saab 9-3, 9-5, Suzuki SX4</p>		<p>760 gr Torque : 60 Nm</p>	<p>Connecting Rod STD</p> <p>Connecting Rod SEMI</p> <p>Bushing Bimetal Locked-Straight</p> <p>Bolt - 10.9 M9x1 L:46 mm</p> <p>Con. Rod OEM : 467 689 51</p>	<p>BMY1402 1 pc.24x10x4cm</p> <p>BMY1402SEMI 1 pc.24x10x4cm</p> <p>BMY1402B 4 pcs. 10x6x4cm</p>
<p>9</p> <p>Opel-Chevrolet Z20DMH</p> <p>2.0 cc</p> <p>R4</p>	<p>Chevrolet Captiva, Cruze, Lacetti, Epica</p> <p>Opel Antara 4x2, 4x4 150ps</p>		<p>885 gr Torque : 50 Nm</p>	<p>Connecting Rod STD</p> <p>Connecting Rod SEMI</p> <p>Bushing Bimetal Locked-Straight</p> <p>Bolt - 10.9 M8x1 L:47 mm</p> <p>Con. Rod OEM : 23510 27300</p>	<p>BMY0602 1 pc.24x10x4cm</p> <p>BMY0602SEMI 1 pc.24x10x4cm</p> <p>BMY0602B 4 pcs. 10x6x4cm</p>

Engine Type	Models	Picture	Sizes (mm)	Products	BMY Reference
1 Porsche M96.01 M96.02 M96.04 3.4 cc B6 Porsche M96.03 M96.05 3.6 cc B6	Boxter, Cayman, Tagra, 911		 <p>720 gr Torque : 70 Nm</p>	Connecting Rod STD Connecting Rod SEMI Bushing Bimetal Locked-Straight Bolt - 10.9 M9x1 L:57 mm Con. Rod OEM : 9961031025R, 9961031026R, 9961031028R	BMY0501 1 pc.24x10x4cm BMY0501SEMI 1 pc.24x10x4cm BMY0501B 6 pcs. 10x6x4cm
 				  	
2 Porsche M96.22 M96.23 M97.20 2.7 cc B6	Boxter, Cayman, Tagra		 <p>610 gr Torque : 70 Nm</p>	Connecting Rod STD Connecting Rod SEMI Bushing Bimetal Locked-Straight Bolt - 10.9 M9x1 L:57 mm Con. Rod OEM : 9961031102R	BMY0502 1 pc.24x10x4cm BMY0502SEMI 1 pc.24x10x4cm BMY0501B 6 pcs. 10x6x4cm
 				  	

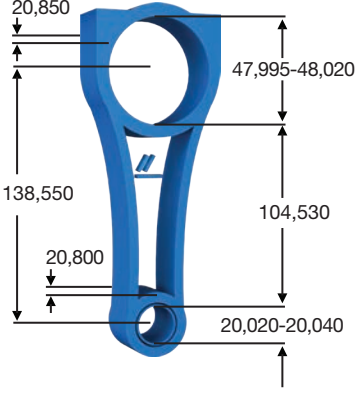



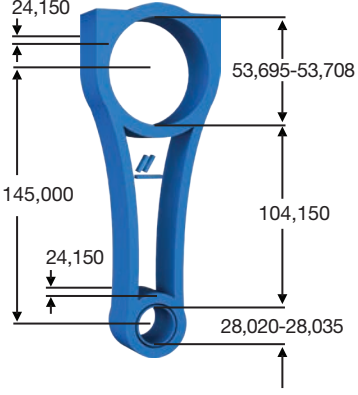





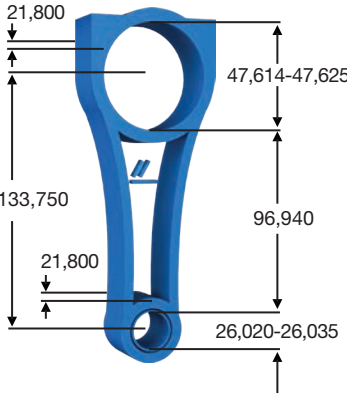

Engine Type	Models	Picture	Sizes (mm)	Products	BMY Reference
1 Peugeot DW8/ XUD9, A, Z, B 1.9 cc R4	Peugeot Partner, Boxer, 306, 406 Citroen Jumper, Jumpy Fiat Scudo, Ducato Suzuki Baleno		 <p>715 gr Torque : 60 Nm</p>	Connecting Rod STD Connecting Rod SEMI Bushing Bimetal Locked-Straight Bolt - 10.9 M9x1 L:46 mm	BMY0801 1 pc.24x10x4cm BMY0801SEMI 1 pc.24x10x4cm BMY0801B 4 pcs. 10x6x4cm
   	  				
2 Peugeot Sofim S8U, S9U 2.5 cc R4	Peugeot Boxer		 <p>1320 gr Torque : 80 Nm</p>	Connecting Rod STD Connecting Rod SEMI Bushing Bimetal Locked-Straight Bolt - 10.9 M10x1,25 L: 58 mm	BMY0802 1 pc.24x10x4cm BMY0802SEMI 1 pc.24x10x4cm BMY0803B 4 pcs. 10x6x4cm
  	  				
3 Peugeot Sofim S8W, S9W 2.8 cc R4	Peugeot Boxer		 <p>1290 gr Torque : 80 Nm</p>	Connecting Rod STD Connecting Rod SEMI Bushing Bimetal Locked-Straight Bolt - 10.9 M10x1,25 L: 58 mm	BMY0803 1 pc.24x10x4cm BMY0803SEMI 1 pc.24x10x4cm BMY0803B 4 pcs. 10x6x4cm
  	  				

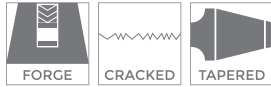

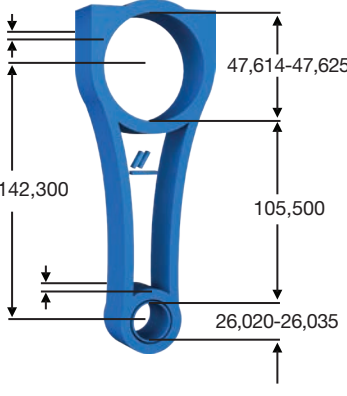

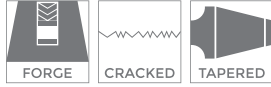

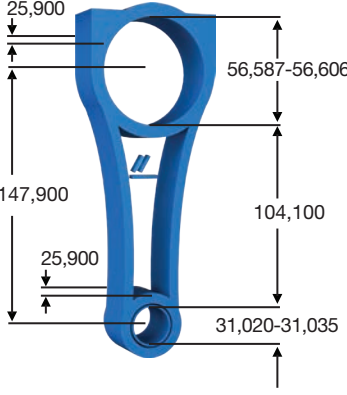

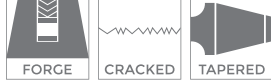

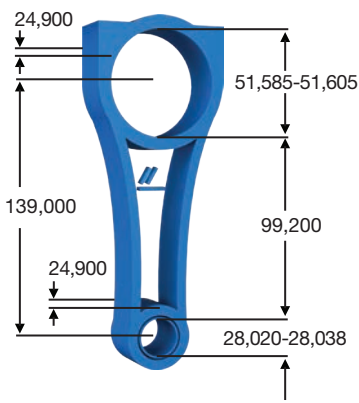
Engine Type	Models	Picture	Sizes (mm)	Products	BMY Reference
4 Peugeot 4HG 110ps 4HH 130ps 4HJ 150ps 2.2 cc R4	Peugeot Boxer Citroen Jumper		 <p>882 gr Torque : 60 Nm 2nd Torque Option : 30 Nm+100 °</p>	Connecting Rod STD	BMY0804 1 pc.24x10x4cm
				Connecting Rod SEMI	BMY0804SEMI 1 pc.24x10x4cm
				Bushing Bimetal Locked-Straight	BMY0804B 4 pcs. 10x6x4cm
				Bolt - 10.9 M9x1 L:46 mm	BMY0805CB 8 pcs. 10x6x4cm
				Con. Rod OEM : 0603 E3/E4/E5	
					
5 Peugeot 4HU, 120ps 4HV 100ps Fiat 4HU 120ps 4HV 100ps 2.2 cc R4	Peugeot Boxer Citroen Jumper		 <p>873 gr Torque : 60 Nm 2nd Torque Option : 30 Nm+100 °</p>	Connecting Rod STD	BMY0805 1 pc.24x10x4cm
				Connecting Rod SEMI	BMY0805SEMI 1 pc.24x10x4cm
				Bushing Bimetal Locked-Straight	BMY0805B 4 pcs. 10x6x4cm
				Bolt - 10.9 M9x1 L:42 mm	BMY0805CB 8 pcs. 10x6x4cm
				Con. Rod OEM PSA : 0603 97/98 Con. Rod OEM FIAT : 9659672280, 9661857980, 9661858180, 9667060880, 9667061080	
					
6 Peugeot DV4 TD/TED4 1.4 cc R4	Peugeot 206, 207, 1007 Ford Fiesta, Fusion Citroen C1, C2, C3, Xsara Mazda 2 Suzuki Liana Toyota Aygo		 <p>500 gr Torque : 45 Nm 2nd Torque Option : 5 Nm + 10 Nm + 130 °</p>	Connecting Rod STD	BMY0806 1 pc.24x10x4cm
				Connecting Rod SEMI	BMY0806SEMI 1 pc.24x10x4cm
				Bushing Bimetal Locked-Straight	BMY0806B 4 pcs. 10x6x4cm
				Bolt - 10.9 M7x1 L: 38 mm	BMY0806CB 8 pcs. 10x6x4cm
				Con. Rod OEM : 0603 88	
					

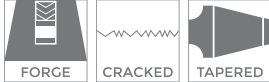
Engine Type	Models	Picture	Sizes (mm)	Products	BMY Reference
7 Peugeot DV6 ATED4B, TED4C 1.6 cc R4	Peugeot 207, 307, 308, 407, Partner, 508 Citroen C3, C4, Berlingo		 <p>600 gr Torque : 45 Nm 2nd Torque Option : 5 Nm + 10 Nm + 130 °</p>	Connecting Rod STD	BMY0807 1 pc.24x10x4cm
	Ford C-Max, Focus, Fiesta MINI Cooper D Mazda 2, 3 Volvo C30, S40, V50/60, S60 Suzuki SX4			Connecting Rod SEMI	BMY0807SEMI 1 pc.24x10x4cm
				Bushing Bimetal Locked-Straight	BMY0807B 4 pcs. 10x6x4cm
				Bolt - 10.9 M7x1 L: 38 mm	BMY0806CB 8 pcs. 10x6x4cm
				Con. Rod OEM : 060392 - 0603C0	
					
8 PSA EP6, EP6C BMW MINI N13/ N18 1.6 cc R4	Peugeot 207, 208, 2008, 308, 3008, 508 Citroen C4, DS3, DS4, C3		 <p>465 gr Torque : 45 Nm 2nd Torque Option : 5 Nm + 15 Nm + 130 °</p>	Connecting Rod STD	BMY0808 1 pc.24x10x4cm
				Connecting Rod SEMI	BMY0808SEMI 1 pc.24x10x4cm
				Bushing Bimetal Locked-Straight	BMY0808B 4 pcs. 10x6x4cm
				Bolt - 10.9 M7x1 L: 38 mm	BMY0806CB 8 pcs. 10x6x4cm
				Con. Rod OEM : 0603 E0 0603 A0, 0628 T1	
					
9 Peugeot DW10BTED4/ RHK/ RHR/RHF/ RHJ/FD/FC Volvo D4204T/ D4204T2 2.0 cc R4	Peugeot Partner/Berlingo 307, 407, 607, 807 308, 508 Volvo C30, C70, S40, V50, S80, V70 2.0D		 <p>780 gr Torque : 70 Nm</p>	Connecting Rod STD	BMY0810 1 pc.24x10x4cm
				Connecting Rod SEMI	BMY0810SEMI 1 pc.24x10x4cm
				Bushing Bimetal Locked-Straight	BMY0810B 4 pcs. 10x6x4cm
				Bolt - 10.9 M9x1 L:56 mm	
				Con. Rod OEM : 0603 90 - 0603 A6	
					

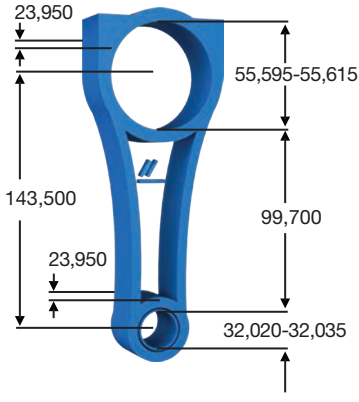

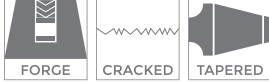

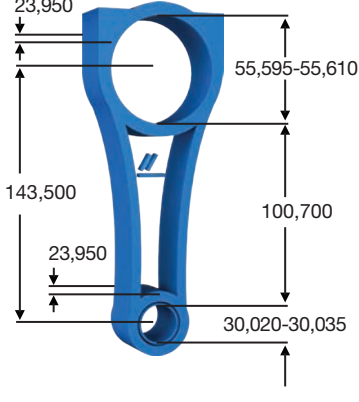

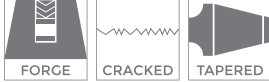



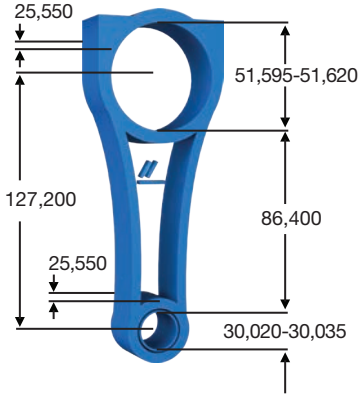



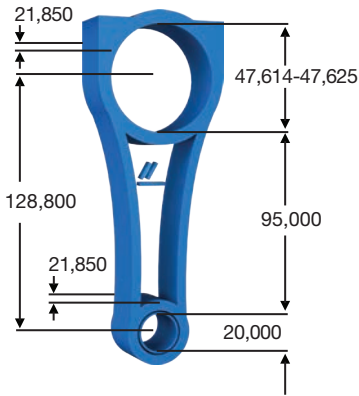

Engine Type	Models	Picture	Sizes (mm)	Products	BMY Reference
10					
Peugeot DW10CTED4, DW10FUD RHH, RHE, RH02	Peugeot 308, 407, 508, 3008, 5008, RCZ, Partner			Connecting Rod STD	BMY0811 1 pc.24x10x4cm
2.0 cc	Citroen C4, C5, DS4, DS5, Berlingo, Jumpy, Xsara			Connecting Rod SEMI	BMY0811SEMI 1 pc.24x10x4cm
R4	Ford Focus, C-Max, Transit Panther C			Bushing Bimetal Locked-Straight	BMY0811B 4 pcs. 10x6x4cm
				Bolt - 10.9 M9x1 L:46 mm	
				Con. Rod OEM : 0603 C5, 1613238180, 1406651180, 1606651180	
			790 gr Torque : 60 Nm		





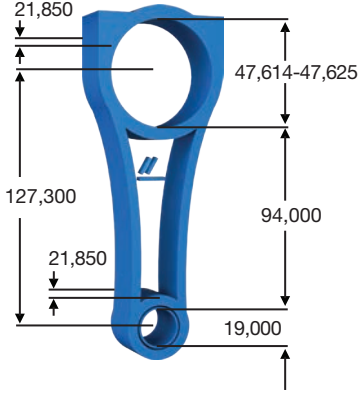





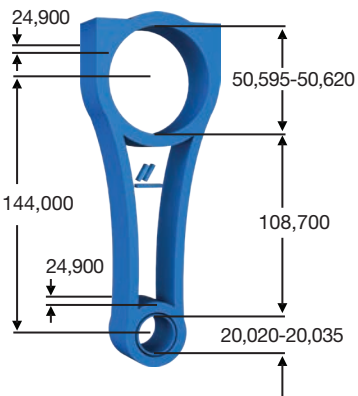





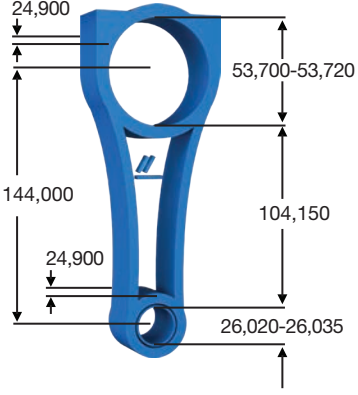









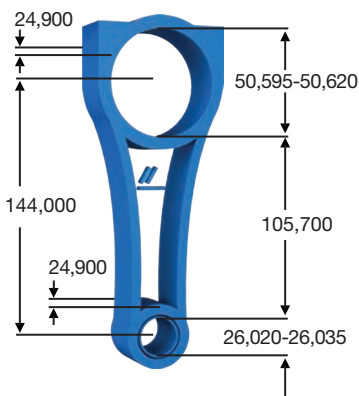







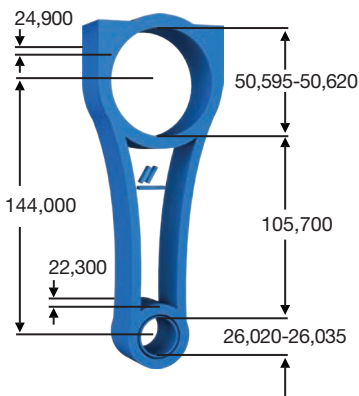

Engine Type	Models	Picture	Sizes (mm)	Products	BMY Reference
1 Renault K9K 1.5 cc R4	Renault Clio, Kangoo,Fluence Megane, Latitude, Laguna, Captur Dacia Logan, Sandero, Duster Nissan Micra, Qashqai, Juke Mercedes-Benz Citan, A-B-CLA 180 CDI Suzuki Jimny			Connecting Rod STD Connecting Rod SEMI Bushing Bimetal Locked-Straight Bolt - 10.9 M9x1 L:42 mm	BMY0901 1 pc.24x10x4cm BMY0901SEMI 1 pc.24x10x4cm BMY0901B 4 pcs. 10x6x4cm BMY0901CB 8 pcs. 10x6x4cm
			535 gr Torque : 60 Nm 2nd Torque Option : 20 Nm + 45 °		Con. Rod OEM : 770 147 5074
2 Renault K9K 846, K9K 608, 872 Mercedes-Benz OM607, OM608 1.5 cc - R4 Euro 5/6	Renault Megane IV, Kadjar, Scenic IV, Clio Captur Mercedes-Benz A, B, CLA, GLA Class, Citan Infiniti Q30 Nissan Note, Micra Dacia Lodgy			Connecting Rod STD Connecting Rod SEMI Bushing Bimetal Locked-Straight Bolt - 10.9 M9x1 L:42 mm	BMY0902 1 pc.24x10x4cm BMY0902SEMI 1 pc.24x10x4cm BMY0901B 4 pcs. 10x6x4cm BMY0901CB 8 pcs. 10x6x4cm
			Used in forged-steel piston engines. Es wird in geschmiedeten Stahlkolbenmotoren. Dövme çelik pistonlu motorlarda kullanılır.		Con. Rod OEM : 121008820R, 607 030 0420
3 Renault G9U 2.5 cc R4	Renault Master II, LagunaNissan InterstarOpel Movano			Connecting Rod STD Connecting Rod SEMI Bushing Bimetal Locked-Straight Bolt - 10.9 M9x1 L:42 mm	BMY0913 1 pc.24x10x4cm BMY0913SEMI 1 pc.24x10x4cm BMY0913B 4 pcs. 10x6x4cm BMY0901CB 8 pcs. 10x6x4cm
			870 gr Torque : 60 Nm 2nd Torque Option : 20 Nm + 45 °		Con. Rod OEM : 770 147 3615



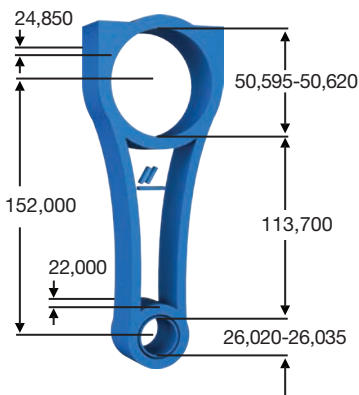

Engine Type	Models	Picture	Sizes (mm)	Products	BMY Reference
4 Renault F9Q 1.9 cc R4	Renault Master, Trafic, Laguna, Kangoo, Megane, Clio			Connecting Rod STD	BMY0914 1 pc.24x10x4cm
	Opel Vivaro Mitsubishi Carisma, Spacestar Volvo S40 Suzuki Grand Vitara			Connecting Rod SEMI	BMY0914SEMI 1 pc.24x10x4cm
				Bushing Bimetal Locked-Straight	BMY0914B 4 pcs. 10x6x4cm
				Bolt - 10.9 M9x1 L:42 mm	BMY0901CB 8 pcs. 10x6x4cm
				Con. Rod OEM : 770 147 6250	
					
5 Renault M9R 2.0 cc R4	Renault Megane, Laguna, Master, Trafic			Connecting Rod STD	BMY0915 1 pc.24x10x4cm
	Nissan Qashqai, X-Trail			Connecting Rod SEMI	BMY0915SEMI 1 pc.24x10x4cm
				Bushing Bimetal Locked-Straight	BMY0915B 4 pcs. 10x6x4cm
				Bolt - 10.9 M9x1 L:42 mm	BMY0901CB 8 pcs. 10x6x4cm
				Con. Rod OEM : 770 147 7831	
					
6 Renault M9R 2.0 cc R4	Renault Megane, Laguna, Master, Trafic			Connecting Rod STD	BMY0916 1 pc.24x10x4cm
	Nissan Qashqai, X-Trail			Connecting Rod SEMI	BMY0916SEMI 1 pc.24x10x4cm
				Bushing Bimetal Locked-Straight	BMY0916B 4 pcs. 10x6x4cm
				Bolt - 10.9 M9x1 L:42 mm	BMY0901CB 8 pcs. 10x6x4cm
				Con. Rod OEM : 770 147 7831	
					





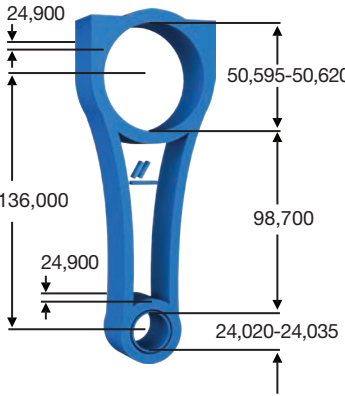
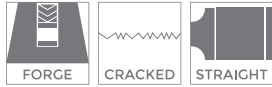

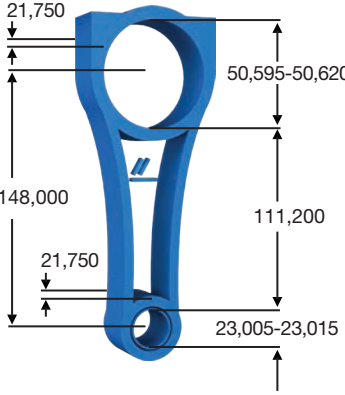
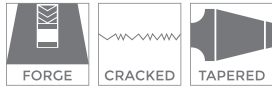

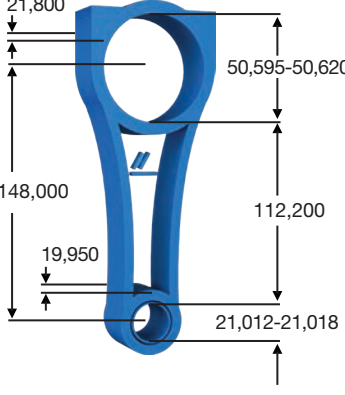
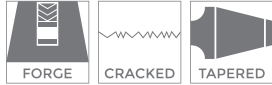

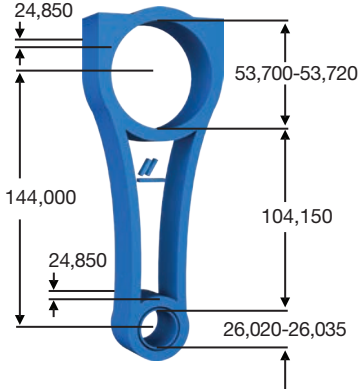
Engine Type	Models	Picture	Sizes (mm)	Products	BMY Reference
7					
Renault G9T 2.2 cc R4	Renault Laguna, Espace, Master, Trafic, Vel Satis Opel/Vauxhall Movano, Vivaro Nissan Interstar, Primastar			Connecting Rod STD Connecting Rod SEMI Bushing Bimetal Locked-Straight Bolt - 10.9 M9x1 L:42 mm	BMY0917 1 pc.24x10x4cm BMY0917SEMI 1 pc.24x10x4cm BMY0913B 4 pcs. 10x6x4cm BMY0901CB 8 pcs. 10x6x4cm
			873 gr Torque : 60 Nm 2nd Torque Option : 20 Nm + 45 °		Con. Rod OEM : 770 147 2847
8					
Renault M9T 2.3 cc R4	Renault Master, Koleos, Alaskan Opel/Vauxhall Movano Nissan NV400, Navara, Qashqai, X-Trail, Primastar Mercedes-Benz X-Class			Connecting Rod STD Connecting Rod SEMI Bushing Bimetal Locked-Straight Bolt - 10.9 M9x1 L:42 mm	BMY0918 1 pc.24x10x4cm BMY0918SEMI 1 pc.24x10x4cm BMY0915B 4 pcs. 10x6x4cm BMY0901CB 8 pcs. 10x6x4cm
			805 gr Torque : 60 Nm 2nd Torque Option : 20 Nm + 45 °		Con. Rod OEM : 121004942R
9					
Renault R9M Mercedes-Benz OM626 1.6 cc R4	Renault Talisman, Fluence Dacia Duster, Logan, Sandero Mercedes-Benz A, B, C, CLA-Class, Citan Nissan Juke, Almera, Cube, Micra, Note			Connecting Rod STD Connecting Rod SEMI Bushing Bimetal Locked-Straight Bolt - 10.9 M9x1 L:42 mm	BMY0919 1 pc.24x10x4cm BMY0919SEMI 1 pc.24x10x4cm BMY0916B 4 pcs. 10x6x4cm BMY0901CB 8 pcs. 10x6x4cm
			655 gr Torque : 60 Nm 2nd Torque Option : 20 Nm + 45 °		OEM : 121006304R, 121000425R, 95518876 Without Oil Hole

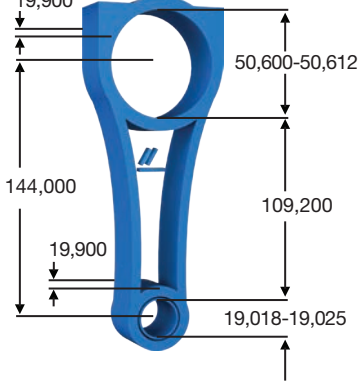

Engine Type	Models	Picture	Sizes (mm)	Products	BMY Reference
10					
Renault R9M	Renault Talisman,		 <p>25,550 51,595-51,620 127,200 86,400 25,550 30,020-30,035</p>	Connecting Rod STD	BMY0920 1 pc.24x10x4cm
Mercedes-Benz OM626	Fluence			Connecting Rod SEMI	BMY0920SEMI 1 pc.24x10x4cm
1.6 cc	Dacia Duster, Logan, Sandero			Bushing Bimetal Locked-Straight	BMY0916B 4 pcs. 10x6x4cm
R4	Mercedes-Benz A, B, C, CLA-Class, Citan			Bolt - 10.9 M9x1 L:42 mm	BMY0901CB 8 pcs. 10x6x4cm
	Nissan Juke, Almera, Cube, Micra, Note				121006304R, 121000425R With Oil Hole
			655 gr Torque : 60 Nm 2nd Torque Option : 20 Nm + 45 °	  	
11					
Renault K4M 1.6	Renault Clio I/III, Kangoo, Scenic I/II,		 <p>21,850 47,614-47,625 128,800 95,000 21,850 20,000</p>	Connecting Rod STD	BMY0921 1 pc.24x10x4cm
K4J 1.4	Megane I/II, Laguna, Modüs, R9, R12			Bolt - 10.9 M9x1 L:42 mm	
C1J, C2J, C3J, C6J, C2L	Volvo 340, 343, 345				
810 01/02/03/05/06 842 01, 847 05/06					
Volvo B14, B14E			550gr Torque : 60 Nm		Con. Rod OEM : 7701471281, 121009455R, 7701477612, 8200454199, 6001543049, 7701465085
				  	
12					
Renault K7M 1.6	Renault Clio, Megane II/Coupe, 19, Express		 <p>21,850 47,614-47,625 127,300 94,000 21,850 19,000</p>	Connecting Rod STD	BMY0922 1 pc.24x10x4cm
K7J 1.4				Bolt - 10.9 M9x1 L:42 mm	
E6J 1.4	Dacia Logan, Solenza				
E7J 1.4 E5F 1.2 E7F 1.2					
			530gr Torque : 60 Nm		Con. Rod OEM : 121000999R, 7701476393
				  	

Engine Type	Models	Picture	Sizes (mm)	Products	BMY Reference
<p>1</p> <p>Volkswagen APT, AGN, ARG APU, AWU, AUM, AWT, BJX, BKF</p> <p>1.8 cc</p> <p>R4</p>	<p>Volkswagen Passat, Golf Bora, Jetta</p> <p>Audi A3, A4, A6, TT</p> <p>Seat Leon, Toledo, Ibiza</p> <p>Skoda Octavia, Superb</p>		 <p>560 gr Torque : 50 Nm</p>	<p>Connecting Rod STD</p> <p>Connecting Rod SEMI</p> <p>Bushing Bimetal Locked-Straight</p> <p>Bolt w. Nut- 12.9 M8x1 L:54 mm</p> <p>Con. Rod OEM : 027 198 401 B</p>	<p>BMY1001 1 pc.24x10x4cm</p> <p>BMY1001SEMI 1 pc.24x10x4cm</p> <p>BMY1001B 4 pcs. 10x6x4cm</p>
 	  				
<p>2</p> <p>Volkswagen/Audi Seat/Skoda, AXD, AXE, AZV, BAC, BGW, BHW, BJJ, BJK, BJL, BJM, BKD, BLJ, BLK, BMM, BMN, BMP, BNZ, BPC, BPD, BPW, BPE, BPZ, BRT, BSS, BSV, BVH, BVW, CAAA, CAAB, CAAC, CAAD, CAAE, CBAA, CBAB, CBAC, CBBA, CBBB, CBDA, CBDB, CBDC, CBEA, CBHA, CBJA, CBJB, CBKA, CCHA, CCHB, CDBA, CDCA, CEBA, CEBB, CECA, CECB, CEGA, CFCA, CFFA, CFFB, CFFD, CFFE, CFGB, CFGC, CFGD, CFHA, CFHB, CFHC, CFHD, CFHE, CFHF, CFJA, CFJB, CJAA, CJDA, CJDD, CKRA, CKTB, CKTC, CKUB, CKUC, CLCA, CLCB, CLJA, CLLA, CLLB, CNEA, CNFA, CNFB, CSHA, CSLB, CSNA</p> <p>2.0 - 2.5 cc</p> <p>R4</p>	<p>Volkswagen Crafter, Passat, Transporter</p> <p>Audi A4, A6, A8</p> <p>Seat Toledo, Leon</p> <p>Skoda Octavia, Superb</p>		 <p>670 gr Torque : 50 Nm 2nd Torque Option : 30 Nm + 90 °</p>	<p>Connecting Rod STD</p> <p>Connecting Rod SEMI</p> <p>Bushing Bimetal Locked-Straight</p> <p>Bolt - 10.9 M8x1 L:44 mm</p> <p>Con. Rod OEM : 038 105 401 J 038 198 401 D, 038 198 401 E, 038 198 401 F</p>	<p>BMY1002 1 pc.24x10x4cm</p> <p>BMY1002SEMI 1 pc.24x10x4cm</p> <p>BMY1002B 4 pcs. 10x6x4cm</p> <p>BMY1002CB 8 pcs. 10x6x4cm</p>
  	  				

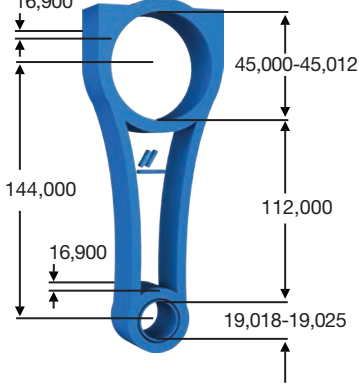
Engine Type	Models	Picture	Sizes (mm)	Products	BMY Reference
<p>3</p> <p>Volkswagen BSU, ATJ, BRU, BSW, AUY, ARL, ANU, BTB, AVQ, AVB, BLS, BXE, BXF, BXJ, BMT Audi ANU, ATJ, AVB Seat BJB, BLS, BXE, BXF, BXJ Skoda BJB, BLS, BXE</p> <p>1.9 cc</p> <p>R4</p>	<p>Volkswagen Caddy, Passat, Jetta, Bora, Touran Audi A4, A6 Seat Toledo, Leon, Altea, Ibiza</p> <p>Skoda Octavia, Superb</p>		 <p>635 gr Torque : 50 Nm 2nd Torque Option : 30 Nm + 90 °</p>	<p>Connecting Rod STD</p> <p>Connecting Rod SEMI</p> <p>Bushing Bimetal Locked-Straight</p> <p>Bolt - 10.9 M8x1 L:44 mm</p> <p>Con. Rod OEM : 038 105 401 G, 038 198 401 H</p>	<p>BMY1003 1 pc.24x10x4cm</p> <p>BMY1003SEMI 1 pc.24x10x4cm</p> <p>BMY1002B 4 pcs. 10x6x4cm</p> <p>BMY1002CB 8 pcs. 10x6x4cm</p>
  		  			
<p>4</p> <p>Volkswagen Audi/Seat BAY, BMS, BNM BNV, BWB, AMF, CUSA</p> <p>1.4 cc</p> <p>R3</p>	<p>Volkswagen Polo, Lupo</p> <p>Audi A2</p> <p>Seat Ibiza, Leon</p>		 <p>610 gr Torque : 50 Nm 2nd Torque Option : 30 Nm + 90 °</p>	<p>Connecting Rod STD</p> <p>Connecting Rod SEMI</p> <p>Bolt - 10.9 M8x1 L:44 mm</p> <p>Con. Rod OEM : 045 105 401 B/C, 04B 105 401 C</p>	<p>BMY1004 1 pc.24x10x4cm</p> <p>BMY1004SEMI 1 pc.24x10x4cm</p> <p>BMY1002CB 8 pcs. 10x6x4cm</p>
 		  			
<p>5</p> <p>Volkswagen Audi/Seat/Skoda CAYA, CAYB, CAYC, CAYE, CLHA, CRKA, CFWA</p> <p>1,2 - 1,6 cc</p> <p>R3 - R4</p>	<p>Volkswagen Caddy, Golf Jetta, Passat Polo 1.2TDI</p> <p>Audi A3</p> <p>Seat Ibiza, Leon</p> <p>Skoda Octavia, Superb</p>		 <p>630 gr Torque : 50 Nm 2nd Torque Option : 30 Nm + 90 °</p>	<p>Connecting Rod STD</p> <p>Connecting Rod SEMI</p> <p>Bushing Bimetal Locked-Straight</p> <p>Bolt - 10.9 M8x1 L:44 mm</p> <p>Con. Rod OEM : 03L 105 401 A</p>	<p>BMY1005 1 pc.24x10x4cm</p> <p>BMY1005SEMI 1 pc.24x10x4cm</p> <p>BMY1002B 4 pcs. 10x6x4cm</p> <p>BMY1002CB 8 pcs. 10x6x4cm</p>
 		  			

Engine Type	Models	Picture	Sizes (mm)	Products	BMV Reference
<p>6</p> <p>Volkswagen Audi CR, CS, CY, JX, KY, ME, MF, SB, 68A, 68B, 68C, ADK</p> <p>1,6 - 1,7 cc</p> <p>R4</p>	<p>Volkswagen T3, Golf, Jetta, Santana, Rabbit</p> <p>Audi 80, 90,</p> <p>4000</p>		 <p>24,900 50,595-50,620 136,000 98,700 24,900 24,020-24,035</p> <p>630 gr Torque : 60 Nm</p>	<p>Connecting Rod STD BMV1006 1 pc.24x10x4cm</p> <p>Bushing Bimetal Locked-Straight BMV1006B 4 pcs. 10x6x4cm</p> <p>Bolt - 10.9 M9x1 L : 46mm</p> <p>Con. Rod OEM : 068 198 401 D</p>	<p>Force, Cracked, Straight</p> 
<p>7</p> <p>Volkswagen BZB, CABD, CDAA, CDAB, CDHA, CDHB, CJEB, CHED, CJEE, CJSA, CJSB, CJSC, CNSA, CNSB, CPKA, CPRA, CYGA, DAJA, DAJB,</p> <p>1,8 cc TFSI</p> <p>R4</p>	<p>Volkswagen Passat, Jetta, Polo, Golf, Beetle, CC, Sharan</p> <p>Audi A1, A3, A4, A5, A6, TT</p> <p>Skoda Superb, Octavia, Yeti</p> <p>Seat Altea, Leon, Toledo, Exeo, Alhambra</p>		 <p>21,750 50,595-50,620 148,000 111,200 21,750 23,005-23,015</p> <p>565 gr Torque : 50 Nm</p>	<p>Connecting Rod STD BMV1007 1 pc.24x10x4cm</p> <p>Bolt - 10.9 M8x1 L:47 mm</p> <p>Con. Rod OEM : 06J 198 401 H, 06J 198 401 D</p>	<p>Force, Cracked, Tapered</p> 
<p>8</p> <p>Volkswagen Seat/Skoda BZB, CEA, CEAA, CGYA, BYJ</p> <p>Audi BYT, BZB, CABA, CABB, CABD</p> <p>1,8 cc TSI, TFSI</p> <p>R4</p>	<p>Volkswagen Tiguan, Passat, CC</p> <p>Audi A3, A4, A5</p> <p>Skoda Superb, Octavia</p> <p>Seat Altea/XL, Leon, Toledo</p> <p>VW FAW Magotan, Sagitar</p>		 <p>21,800 50,595-50,620 148,000 112,200 19,950 21,012-21,018</p> <p>520 gr Torque : 50 Nm</p>	<p>Connecting Rod STD BMV1008 1 pc.24x10x4cm</p> <p>Connecting Rod SEMI BMV1008SEMI 1 pc.24x10x4cm</p> <p>Bushing Bimetal Locked-Straight BMV1008B 4 pcs. 10x6x4cm</p> <p>Bolt - 10.9 M8x1 L: 47 mm</p> <p>Con. Rod OEM : 06H 198 401 Q, 06J 198 401 F, 06J 198 401 K</p>	<p>Force, Cracked, Tapered</p> 

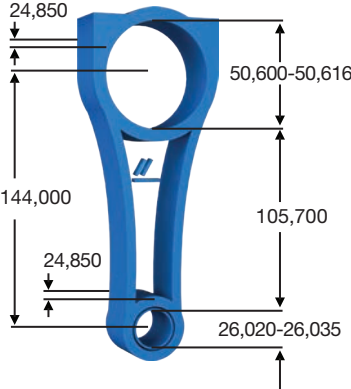
Engine Type	Models	Picture	Sizes (mm)	Products	BMY Reference
9 Volkswagen/ Audi/Skoda CNHA, CNHC, CRLB, CRLD, DDAA 2,0 cc R4	Golf VII, Golf Van, Passat, Passat Alltrack, Transporter, Multivan A3, A4 Avant, A4 Allroad, A5, A6, A6 Avant, A6 Allroad, Q5 Superb III		 <p>640 gr Torque : 50 Nm 2nd Torque Option : 30 Nm + 90 °</p>	Connecting Rod STD Connecting Rod SEMI Bushing Bimetal Locked-Straight Bolt - 10.9 M8x1 L:44 mm Con. Rod OEM: 04L 105 401 A (04LA)	BMY1009 1 pc.24x10x4cm BMY1009SEMI 1 pc.24x10x4cm BMY1002B 4 pcs. 10x6x4cm BMY1002CB 8 pcs. 10x6x4cm
 					
10 Volkswagen BLG, BMY, BWK, CAVA, CAVB, CAVC, CAVD, CAVE, CAXA, CDGA, CKMA, CMSB, CNWA, CTHA, CTHB, CTHC, CTHD, CTHE, CTKA, DAGA, Audi CAVG, CAXA, CAXC, CNVA, CTHG, Seat CAVA, CAVE, CAVF, CAXA, CAXC, CNUB, CNWB, CTHA, CTHE, CTHF, CTJB, CTJC Skoda CAVE, CAXA, CAXC, CTHE 1,4 cc TSI R4	Volkswagen Touran, Golf, Polo, Tiguan, Passat, Jetta, Scirocco, Sharan, Beetle, Eos, CC Audi A1, A3 Seat Ibiza, Toledo, Leon Alhambra, Altea Skoda Yeti, Rapid, Octavia, Superb, Fabia VW FAW Sagitar		 <p>514 gr Torque : 50 Nm 2nd Torque Option : 30 Nm + 90 °</p>	Connecting Rod STD Connecting Rod SEMI Bushing Bimetal Locked-Straight Bolt - 10.9 M8x1 L:44 mm Con. Rod OEM : 03C 198 401 A, 03C 198 401 D	BMY1010 1 pc.24x10x4cm BMY1010SEMI 1 pc.24x10x4cm BMY1010B 4 pcs. 10x6x4cm BMY1002CB 8 pcs. 10x6x4cm
					
11 Volkswagen CBZA, CBZB, CYA, CYVB, DJN Audi CBZA, CBZB, CYVA, Seat CBZA, CBZB Skoda CBZA, CBZB, CYVA, DJNB 1,2 cc TSI R4	Volkswagen Touran, Sharan, Jetta, Golf, Beetle, Polo, Caddy Audi A1, A3 Seat Ibiza, Toledo, Leon, Altea Skoda Roomster, Yeti, Fabia, Octavia, Rapid		 <p>427 gr Torque : 50 Nm 2nd Torque Option : 30 Nm + 90 °</p>	Connecting Rod STD Connecting Rod SEMI Bushing Bimetal Locked-Straight Bolt - 10.9 M8x1 L:44 mm Con. Rod OEM : 03F 198 401	BMY1011 1 pc.24x10x4cm BMY1011SEMI 1 pc.24x10x4cm BMY1011B 4 pcs. 10x6x4cm BMY1002CB 8 pcs. 10x6x4cm
					

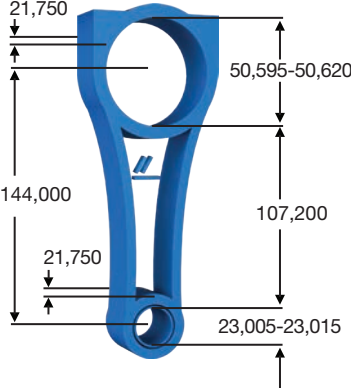
Engine Type	Models	Picture	Sizes (mm)	Products	BMY Reference
<p>12</p> <p>Volkswagen/ ACV, ACV, AGX, AHD, AHY, AJT, ANF, ANG, ANH, ANJ, APA, AUF, AVR Audi 1T, AAT, ABP, AEL</p> <p>2.5cc TDI</p> <p>R5</p>	<p>LT28, LT35, Transporter T4 A6, A6 Avant, 100</p>		 <p>670 gr Torque : 50 Nm</p>	<p>Connecting Rod STD</p> <p>Connecting Rod SEMI</p> <p>Bushing Bimetal Locked-Straight</p> <p>Bolt - 10.9 M8x1 L:44 mm</p>	<p>BMY1012 1 pc.24x10x4cm</p> <p>BMY1012SEMI 1 pc.24x10x4cm</p> <p>BMY1012B 4 pcs. 10x6x4cm</p> <p>BMY1002CB 8 pcs. 10x6x4cm</p> <p>Con. Rod OEM : 028 198 401 H, 028 198 401 F, 074 198 401 B, 028H</p>
<p>13</p> <p>Volkswagen/ Seat, Skoda CAWA, CAWB, CBFA, CCTA, CCZA, CCZB, CCZC, CCZD, CDAB, CFPA, CHHA, CHHB, CJKA, CJKB, CJXA, CJXB, CJXC, CJXD, CJXE, CJXG, CNTC, CULA, CULC, CYFB, CZPA, CZPB, DEDA, DJHA, CHHB</p> <p>Audi CPMB, CPSA, CULB, CULC, CVJA, CVKB, CWZA, CYFB, CYMC, CYNB, CYPB, CYPB, CYRB, CYRC, CZPB, DJHA, CESA, DKNA, DLHB CAEA, CAEB, CAED, CAWB, CBFA, CCTA, CCZA, CCZC CDNB, CDNC, CFKA, CHHB, CHHC, CHJA, CJXB, CJXC, CJXD, CJXF, CJXG, CNCB, CNCD, CNCE, CNTC, CPMA</p> <p>Porsche DKNA, DLHB, MCN.CC, MCY.NA, MCY.NB, MCY.PA</p> <p>2.0 cc TFSI/TSI/ FSI</p> <p>R4</p>	<p>Passat, Golf, Multivan, CC, Scirocco, Eos Bettle, Jetta, Sharan, Transporter Caravelle, Bora, Vento Tiguan,T-Roc, Amarok</p> <p>A1, A2, A3, A4, A5, A6, A7, Q2, Q3, Q5, Q7, TT</p> <p>Mecan</p> <p>Leon, Altea, Alhambra, Ateca</p> <p>Superb, Kadiah, Octavia, Yeti</p>		 <p>568 gr Torque : 50 Nm</p>	<p>Connecting Rod STD</p> <p>Bolt - 10.9 M8x1 L: 47 mm</p>	<p>BMY1013 1 pc.24x10x4cm</p> <p>Con. Rod OEM : 06H 198 401 D, 06J 198 401 B 06LB, 06LJ, 06LL</p>

Engine Type	Models	Picture	Sizes (mm)	Products	BMY Reference
1 Deutz BFL 1011 R4			<p>27,000 58,500-58,510 173,260 131,010 27,000 26,020-26,040</p> <p>1175 gr Torque : 100 Nm</p>	Connecting Rod STD	BMY0301 1 pc.30x12x6cm
					Con. Rod OEM : 0428 6691
2 Deutz BFL 1011/F R4			<p>27,000 58,500-58,510 173,260 129,010 27,000 30,020-30,040</p> <p>720 gr Torque : 70 Nm</p>	Connecting Rod STD	BMY0302 1 pc.30x12x6cm
					Con. Rod OEM : 0427 2007, 0417 8999
3 Deutz TD/TCD 3.6 L4 1011N, TD2011 Euro III, IV, V R4			<p>27,000 61,620-61,621 176,000 130,190 27,000 30,020-30,040</p> <p>1160 gr Torque : 110 Nm</p>	Connecting Rod STD	BMY0303 1 pc.30x12x6cm
					Con. Rod OEM : 0428 6940

BMY[®] CONNECTING ROD

Manufacturer: Basaran Motor Ltd. Şti.
Marketing Co: BMY İç ve Dış Tic. Ltd. Şti.

Tax No: 1870527519

Address: Horozluhan Mh. Ahievran Cd. 35,
42110, Konya, Turkey

Tel : +90 332 251 55 65
Fax: +90 332 251 24 26
Web: www.bmy.com.tr

General Information & Sales: bmy@bmy.com.tr

Latin America Sales: export@bmy.com.tr

Eurasia Sales: eurasia@bmy.com.tr
(Russia, Ukraine, Belarus,
Kazakhstan, Turkmenistan)
M: +90 552 312 05 42

Domestic Sales - Support
Inlandsverkäufe - Förderung
Yurtiçi Satış - Destek:
satisdestek@bmy.com.tr
M: +90 506 487 28 51



All Rights
Reserved

Turkey
Discover
the potential

